

ESS Design and Management considering Solar PV to fed off-grid EV Charger

Diogo Santos
Instituto Superior de
Engenharia de Lisboa,
DEEEA,
Lisboa, Portugal,
a43484@alunos.isel.pt

PM Fonte
Instituto Superior de
Engenharia de Lisboa,
DEEEA,
Lisboa, Portugal,
pedro.fonte@isel.pt

Rita Pereira
Instituto Superior de
Engenharia de Lisboa,
DEEEA,
Lisboa, Portugal,
rita.pereira@isel.pt

F. A. Barata
Instituto Superior de
Engenharia de Lisboa,
DEEEA, UnIRE,
Lisboa, Portugal,
filipe.barata@isel.pt

Paulo Almeida
Instituto Superior de
Engenharia de Lisboa,
DEEEA,
Lisboa, Portugal,
paulo.almeida@isel.pt

Armando Cordeiro
Instituto Superior de
Engenharia de Lisboa,
DEEEA, INESC-ID
Lisboa, Portugal,
armando.cordeiro@isel.pt

Ricardo Luís
Instituto Superior de
Engenharia de Lisboa,
DEEEA, INESC-ID
Lisboa, Portugal,
ricardo.luis@isel.pt

Vitor Pires
Department of Electrical
Engineering, ESTSetúbal,
Instituto Politécnico Setúbal,
INESC-ID
Lisboa, Portugal,
vitor.pires@estsetubal.ips.pt

Abstract— The increase of electric vehicles creates several challenges to the electric grid, mainly in those with weak power or off-grid. DC microgrids are becoming more and more important in the context of renewable energy sources, where solar PV systems are dominant. In this paper is proposed the design of a DC system to charge electric vehicles using PV generation and a battery storage system. A single DC-DC converter is used to operate the solar PV array with maximum power point tracking method and controls power flow from PV to storage battery and to the EV, operating as DC EV charger. The operation under various loading conditions is discussed. The performance of the proposed solution was simulated using MATLAB/Simulink software.

Keywords— EV charging, PV production, Energy management, ESS

I. INTRODUCTION

Environmental and economic issues have motivated people to reduce energy costs and increase the efforts to implement clean and renewable energy solutions [1-4]. Electric vehicles (EVs) are gradually playing an increasingly role in the transportation electrification and becoming gradually relevant in the climate changes context [5]. However, there are some unresolved issues related to EV energy storage capability and charging services connected to the electrical distribution network. However, the intention to introduce EVs into the market with the aim of achieving certain environmental targets contrasts with the high percentage of EV energy needs, still being provided by energy sources using fossil fuels. On the other hand, the increasing penetration of EV in the power grid brings new challenges for both EV users and system operators, namely to the electric energy distribution networks. While the consumption to charge an EV is a fraction of the annual national energy consumption, the installed power exclusively to EV chargers connected to distribution energy grids will increase significantly. Due to that, it is necessary to reinforce the distribution power grid to a value near the maximum consumption of EV, which represents an investment with low

value to society. Therefore, it is imperative to develop new solutions to charge EVs using renewable energy sources (RES) and at same time deal with power grid constraints (to meet the power required for the EV charger) [6,7].

Considering that most of the EV can be charged in DC, this work explores the EV charging infrastructure based on DC with bidirectional EV chargers, PV production and energy storage systems. The use of DC avoids the need for AC/DC conversion and allows the usage of only one power converter, making the installation more efficient, less costly, and thus more attractive. In comparison to AC microgrids, DC microgrids are observed to have higher end-to-end efficiency for DC loads. In fact, DC-DC power converters are crucial to provide the integration of RES systems and control algorithms [8].

The PV is a good solution for renewable energy because it produces energy in DC, is available, abundant, predictable, and easy to integrate in off-grid and on-grid systems [3].

Most isolated PV systems based in microgrids tend to be more effective when integrated with battery energy storage systems (BESS) to store the energy produced by the photovoltaic modules during high irradiance periods. This stored energy can, afterwards, be used to charge EVs. Using second-life automotive batteries, it promotes circular economy principles by extending the lifespan of batteries and reducing waste during the recycling process, especially for batteries with commercial value [9]. The storage system can be a solution to maximize the renewable energy usage and allow the installation of EVs charges in a weak power grid, or even in off-grid installations [10]. In this case, a proper dimensioning of BESS is fundamental once if the storage capacity of the BESS is low and it cannot store all the energy produced, it will lead to energy waste [11]. At same time, the maximum output power from the available radiation must be extracted with the support of maximum power point tracking (MPPT) control algorithms combined with DC-DC converters [12]. To mention that the study of the integration and analysis of these systems in the context of the future DC microgrids is fundamental [13].

This work was supported by Instituto Politécnico de Lisboa, reference code: IPL/IDI&CA2023/ECOCHARGER_ISEL.

The rest of the paper is organized as follows: the general architecture of the proposed system is depicted in section II. In section III, the components, and details of the overall system control scheme are evaluated, and in Section IV is presented the EVs load profile and simulation results. Ultimately, the paper is concluded in section V.

II. GENERAL ARCHITECTURE

The proposed off-grid system consists of solar PV array, a classic Buck-Boost bidirectional DC/DC converter and two lithium-ion battery packs; one serving as low voltage storage (BESS) and other with high voltage acting as EV battery. To use a single bidirectional DC-DC converter, the PV panels present a voltage near the EV battery pack once both will be connected to the same HV bus, as depicted in Fig. 1. In this configuration the PV panels cannot directly charge the EV. The converter tracks the maximum power point (MPP) of the PV and controls the power flow from PV to BESS, and from BESS to the EV. The converter acts as buck to operate the solar PV array at the MPP through the switching signal produced by the control algorithm discussed in section IV. The bidirectional converter acts as an interface between the BESS with 48V_{DC} on low voltage side, and EV with 350 V_{DC} on high voltage side. It controls the charging and discharging modes of the BESS. During the charging mode, the bidirectional converter operates as buck converter and during the discharging mode, it operates as boost converter. The various battery operation modes and the control algorithm are depicted in section IV.

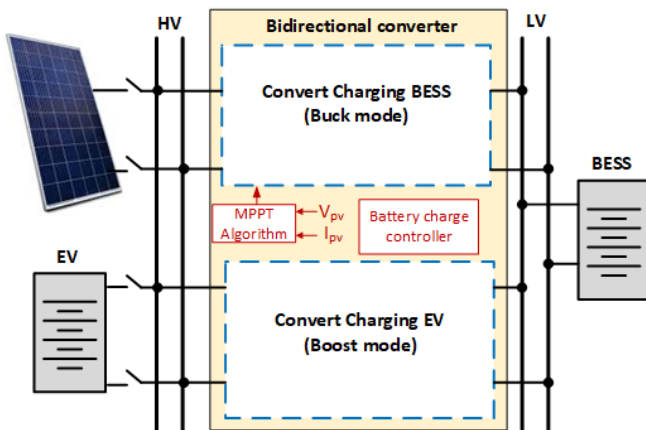

Fig. 1. Overall system.

A. Photovoltaic system

Two resistances equivalent circuit model of a solar PV module is represented in Fig. 2 [14,15]. Where R_s is the series resistance due to the metal contact with the semiconductors and semiconductor layers. The power loss near the edge of the solar cell and due to leakage current through p-n junction is represented by equivalent shunt resistance R_p . These power losses are distributed across the PV module and are represented as lumped resistance for circuit analysis.

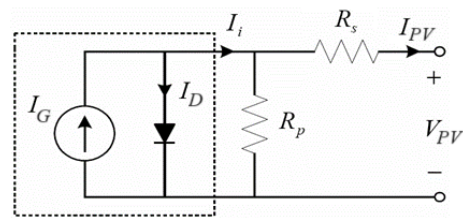

Fig. 2. Equivalent circuit model of practical PV module [12,13].

The nonlinear I-V characteristics of a PV module are defined by the mathematical expressions (1) to (3):

$$I_D = I_0 \left[e^{\left(\frac{q(V_D + I R_s)}{a k T} \right)} - 1 \right] \tag{1}$$

$$I_p = \frac{V_{PV} + I_{PV} R_s}{R_p} \tag{2}$$

$$I_G = I_D + I_p + I_{PV} \tag{3}$$

Where, I_D is the diode current; V_D is the diode voltage; I_0 is the diode saturation current; a is an idealistic factor (nearly 1.0); q is the elementary charge of the electron = $1.6 \times 10^{-19}C$; k is the Boltzmann constant = $1.3806 \times 10^{-23}J.K^{-1}$; T is the temperature in Kelvin. The PV array performance depends on irradiance and temperature variations. When PV array is exposed to higher irradiance, it generates a higher amount of photocurrent I_G . At a constant temperature, maximum power is extracted from a PV module when it is exposed to maximum irradiance ($1kW/m^2$). If irradiance decreases then the maximum point shifts to a lower value, if temperature increases then the maximum power point (MPP) shifts downwards.

The characteristics of the PV modules Apollo Solar Energy ASEC230G6S considered in this work, at Standard Test Conditions, (STC) are given in Table I.

TABLE I. PARAMETERS OF SOLAR PV MODULE AT STC

Parameters	Values
Rated output power	230 W
Open-circuit voltage V_{OC}	36.75 V
Short-circuit current I_{SC}	8.46 A
Voltage at maximum power V_{MPP}	29.19 V
Current at maximum power I_{MPP}	7.88 A
Number of cells	60
Temperature coefficient of V_{OC}	-0.3397 %/deg.C
Temperature coefficient of I_{SC}	-0.0423 %/deg.C

Fig. 3 illustrates the I-V curve and P-V curve showing the irradiance variation effect.

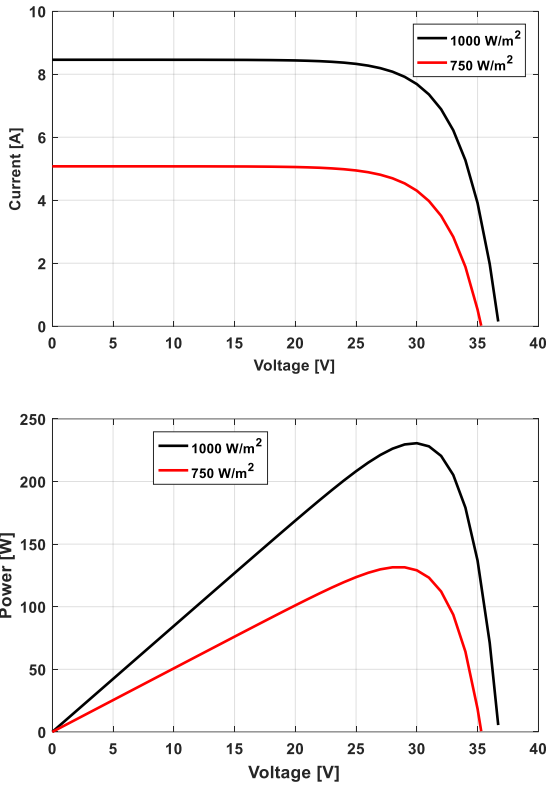

Fig. 3. I-V and P-V characteristics in function of irradiance.

B. PV Array Design

The PV array configuration depends on the available solar irradiation, the energy demand to charge the BESS/VE, and DC bus voltage. Considering the hourly average irradiance values measured in ISEL’s campus between 1/1/2020 and 30/9/2021, (639 days), in Fig. 4 are shown the worst, the best and average case of solar irradiance.

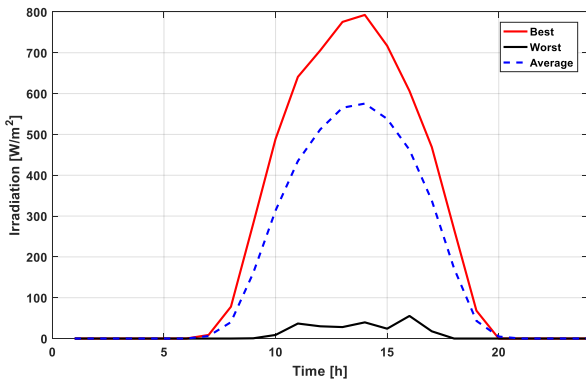

Fig. 4. Maximum, minimum and average hourly irradiance.

This dimensioning is limited by the equipment available in the laboratory. In this work the available BESS has, approximately, 70% of the EV storage capacity (given by the Opel Ampera 16 kWh battery pack), so the PV system was defined in function of BESS capacity (11 kWh). On the other hand, as the HV bus is shared by EV battery and PV array, a configuration with a string of 12 modules in series was chosen, as depicted in table II. At same time, it is concluded that a rated power of 2760 W is enough to charge the BESS considering the irradiance average scenario.

TABLE II. VALUES FOR 12 MODULES IN SERIES OF THE SOLAR PV MODULE APOLLO SOLAR ENERGY ASEC230G6S AT STC

Parameters	Values
Rated output power	2760 W
Open-circuit voltage V_{OC}	441 V
Short-circuit current I_{SC}	8.46 A
Voltage at maximum power V_{MPP}	350.28 V
Current at maximum power I_{MPP}	7.88 A

C. DC System Configuration

To increase batteries lifespan, they should not be charged or discharged beyond a particular state-of-charge (SOC) condition. When the battery operates within these SOC limits, the state of health of the battery is extended. Mathematically, the battery SOC is the ratio between available energy storage capacity and its maximum available capacity, eq. (4). For a Li-ion battery with depth of discharge as 60%, the lower limit of SOC can be set as 20% and the upper limit can be set as 80%, which is usually considered for practical systems [16,17].

$$SOC[\%] = \frac{\text{Available Capacity (Ah)}}{\text{Maximum Available Capacity (Ah)}} \quad (4)$$

The battery is supposed to be selected accordingly to its application. As mentioned in introduction, a second-life battery is proposed to BESS and though its state of health could not be the same as the original, however it can reach the SOC levels proposed for this study. For energy management systems, batteries with higher depth of discharge are preferred as they are designed to provide lower amount of current for a longer period. Li-ion battery has been selected for the microgrid because it has a highly efficient deep cycle battery i.e., it has a high discharge value depth (nearly 70%).

The main system components characteristics are described in Table III.

TABLE III. COMPONENTS ADOPTED TO THE PROPOSED STUDY

Component	Parameters	Values
Bidirectional Converter	Max Output Power	2.2kW
	Low Voltage Side	38-59 V
	Rated Current LV	50 A
	High Voltage Side	280-400 V
	Rated Current HV	7 A
BESS	Capacity	240 Ah
	Rated Voltage	36V - 52.V
	Rated Energy Output	11 kWh
EV Batteries (Opel Ampera)	Capacity	45 Ah
	Rated Voltage	288V - 403.2V
	Rated Energy Output	16 kWh

III. CONTROL ALGORITHMS

A. Maximum Power Point Tracking Algorithm

Incremental conductance (IC) algorithm is one of the most popular and researched MPPT algorithms along with perturb observe algorithm [18-20]. In the IC algorithm, the PV curve slope is computed and the point where the slope is zero is identified as the maximum power point of the PV array. IC MPPT algorithm is governed by equations (5) to (7):

$$\frac{dP}{dV} = 0 \tag{5}$$

Therefore, (5) can be written as (6), which implies (7).

$$\frac{dP}{dV} = \frac{d(VI)}{dV} = V \frac{dI}{dV} + I \frac{dV}{dV} = V \frac{dI}{dV} + I = 0 \tag{6}$$

$$\frac{dP}{dV} = -\frac{I}{V} \tag{7}$$

Tracking speed and output fluctuations depends on the chosen step size. For a large step size, MPP tracking speed is higher, but the controller oscillates around the maximum power point (MPP) whereas for a small step size, the MPP tracking speed drops, but the fluctuations are very reduced. Fig. 5 shows an overview of the Incremental Conductance MPPT algorithm.

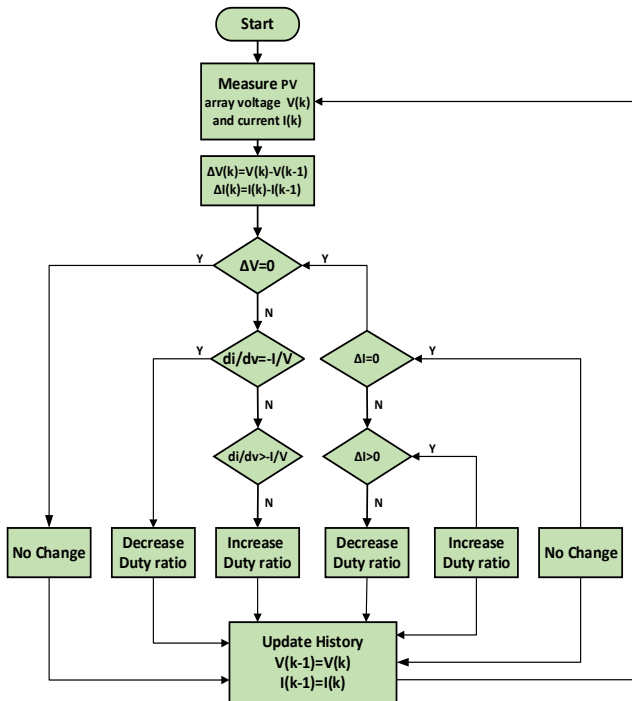

Fig. 5. Conventional incremental conductance MPPT algorithm.

In Figs. 6 to 8 the voltage, current and power resulting from the MPPT algorithm to the average irradiance are shown. The current and the power follow explicitly the irradiance while the voltage is adapted to each value of irradiance to obtain the maximum power.

B. Power flow control

As shown in Fig. 1 the system is composed by only one DC-DC converter, so the solar PV does not directly charge the EV. The BESS is charged in function of the PV resource following the MPPT. The power flow from BESS to EV batteries is based on CHAdEMO protocol. The EV charging current is constant, limited by the converter power, up to reach the rated voltage.

IV. SIMULATION MODELS AND RESULTS

To analyse the energy flow between different components it was necessary to develop a simulation model through software *Matlab/Simulink*, as depicted in Fig 9.

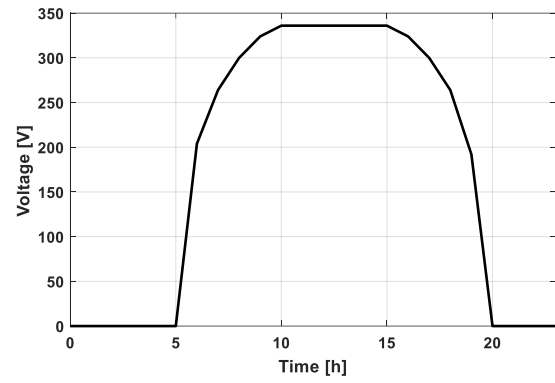

Fig. 6. PV voltage for the average scenario.

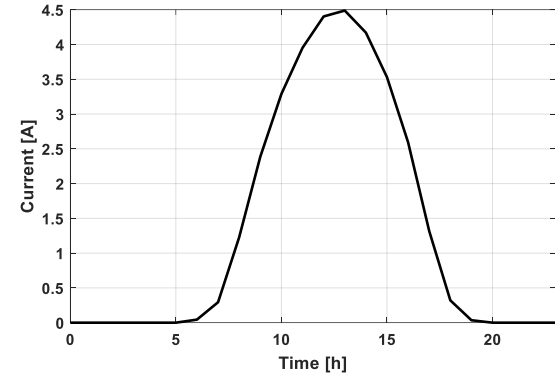

Fig. 7. PV current for the average scenario.

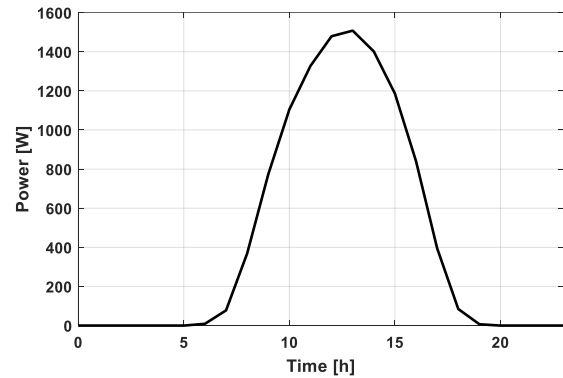

Fig. 8. PV power for the average scenario.

The developed model simulates a long-term behaviour of a battery charging/discharging using a pair of controlled current sources, one for each direction of power flow (charging and discharging), as a simplified representation of a bidirectional DC-DC converter. The current source values are adjusted based on the converter's efficiency, batteries voltages, and the desired charging or discharging current. This approach allows the omission of the switching dynamics of the power electronic devices in the DC-DC converter, which enables the use of a personal computer to simulate a 24-hour period.

The first case study shows the results from energy transfer between the PV system and the BESS considering the best, the worst and average hourly irradiance values. The initial SOC of BESS was defined as 20%. The current evolution for 24 hours is depicted in Fig.10. While the evolution of the SOC is shown in Fig. 11. It was considered the charging current as negative while the discharge as positive.

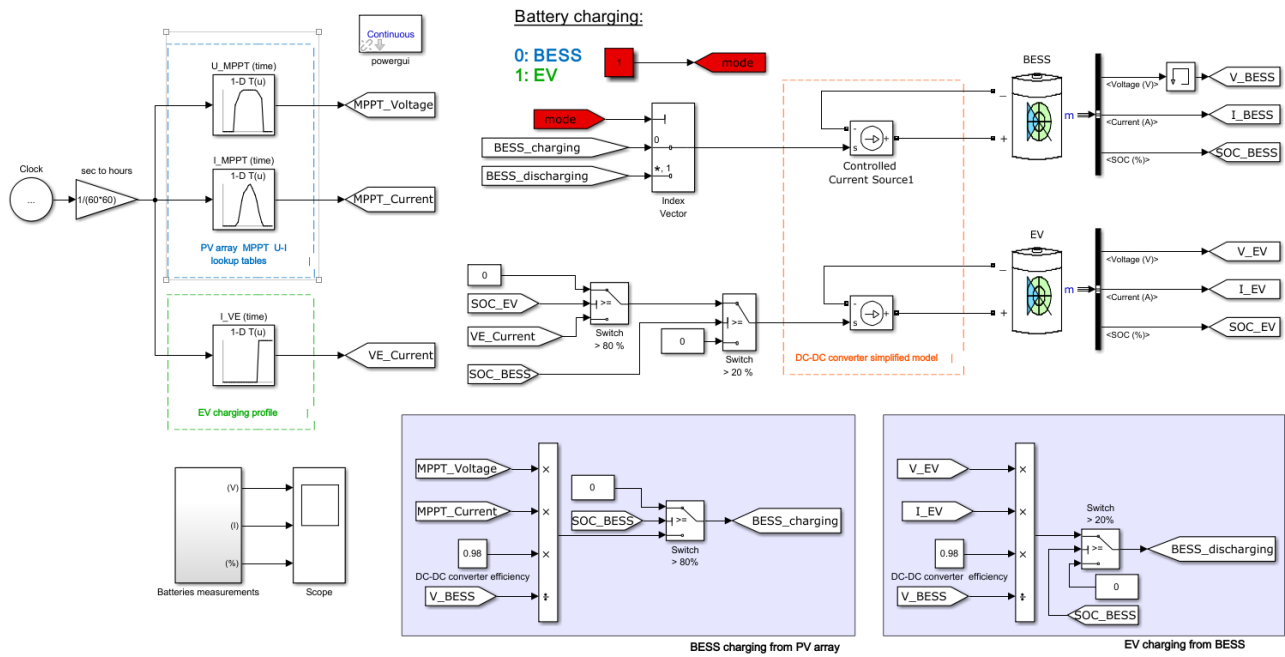

Fig. 9. Simulink model of complete system

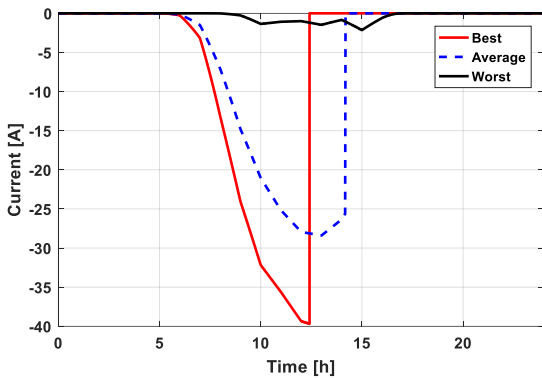

Fig. 10. Evolution of current from PV to BESS.

Analysing Fig. 10 and 11, it is clear the relation between the SOC and the current. When the SOC reach 80% the charging stops. In the best case it takes approximately 6.5 hours, while in the average case it takes almost 8 hours. In the worst case the irradiation was so low that only increase the SOC approximately in 3.5%. In Fig. 12 the BESS voltages are depicted showing its increment during the charging period.

The second simulation result is dedicated to showing the energy transfer between the BESS and the EV, which is considered as a constant load and equal to the converter rated power. In Fig. 13 the current transference between BESS and EV is shown. As the initial SOC for the BESS is the same for best and average scenario, the results will be the same. The relation between current is proportional to the voltages in each battery pack and consider a converter an efficiency of 98%. As the BESS has only 70% of the EV battery capacity and discharged from 80% up to 20% the energy transferred was 6.6 kWh.

The time evolution shown in Fig. 14, represents the charging of EV through the BESS, where it can be observed that only a maximum of 40% of the total energy absorbed by the EV is transferred. In the worst-case scenario, the available

energy stored in BESS is almost neglectable and the results are not shown.

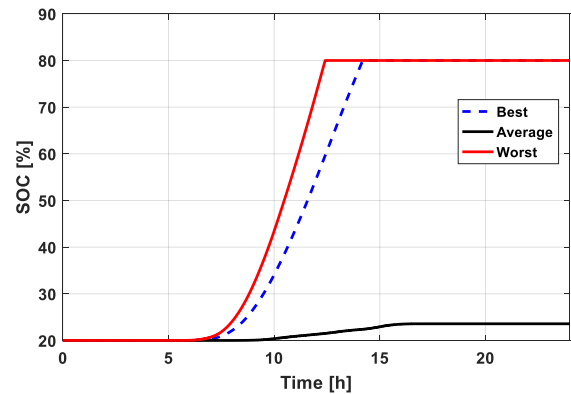

Fig. 11. SOC evolution during the BESS charging

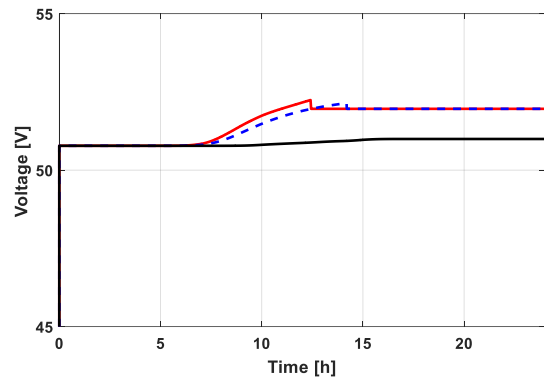

Fig. 12. Voltage evolution during the BESS charging

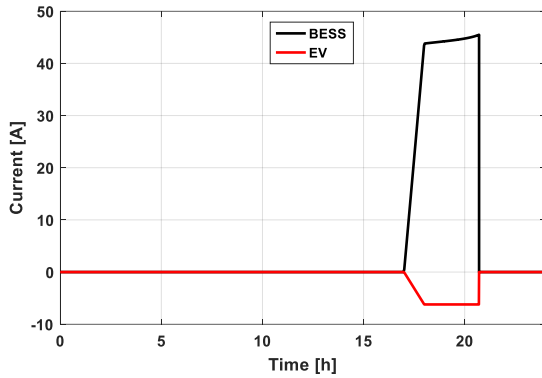

Fig. 13. Current evolution in BESS and EV.

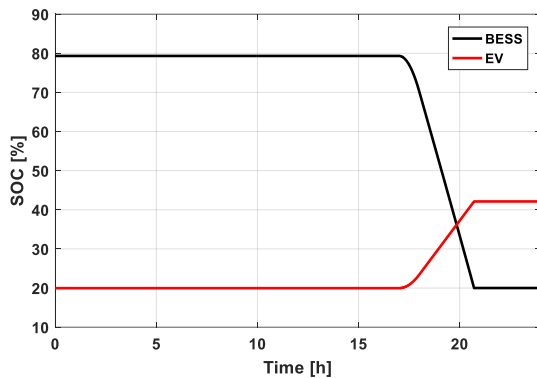

Fig. 14. SOC evolution of BESS and EV.

V. CONCLUSION

This paper proposed the design and simulation of a DC system to charge electric vehicles using PV generation and a battery storage system isolated from the grid. The PV array design and the battery sizing were discussed considering 2 scenarios. The first scenario shows the results from energy transfer between the PV system and the BESS considering the best, the worst and average hourly irradiance values, and the second scenario shows the energy transfer between the BESS and the EV, where the EV is considered as a constant load and equal to the converter rated power.

An MPPT algorithm was here detailed and presented to get the maximum power available in the solar irradiance. The performances for a 24-hour profile of solar irradiance and EV load were shown.

From these preliminary studies is possible to infer that the PV power must be determined carefully to decrease the risk of lack of stored energy that makes it impossible fully charge the EV. Future works must address this issue.

REFERENCES

[1] A. Qazi et al., "Towards Sustainable Energy: A Systematic Review of Renewable Energy Sources, Technologies, and Public Opinions," in *IEEE Access*, vol. 7, pp. 63837-63851, 2019, doi: 10.1109/ACCESS.2019.2906402.

[2] F. Z. Peng, C. -C. Liu, Y. Li, A. K. Jain and D. Vinnikov, "Envisioning the Future Renewable and Resilient Energy Grids—A Power Grid Revolution Enabled by Renewables, Energy Storage, and Energy Electronics," in *IEEE Journal of Emerging and Selected Topics in Industrial Electronics*, vol. 5, no. 1, pp. 8-26, Jan. 2024, doi: 10.1109/JESTIE.2023.3343291.

[3] M. Cakir, I. Cankaya, I. Garip and I. Colak, "Advantages of Using Renewable Energy Sources in Smart Grids," 10th International Conference on Smart Grid (icSmartGrid), pp. 436-439, June 2022.

[4] B. Srikanth Goud, B Loveswara rao, Ch Rami Reddy, "Essentials for Grid Integration of Hybrid Renewable Energy Systems: A Brief Review", *International Journal of Renewable Energy Research*, vol. 10, n. 2, pp. 813-830, June 2020.

[5] K. M. Muttaqi, M. R. Islam and D. Sutanto, "Future Power Distribution Grids: Integration of Renewable Energy, Energy Storage, Electric Vehicles, Superconductor, and Magnetic Bus," in *IEEE Transactions on Applied Superconductivity*, vol. 29, no. 2, pp. 1-5, March 2019, Art no. 3800305, doi: 10.1109/TASC.2019.2895528.

[6] G. G. Farivar et al., "Grid-Connected Energy Storage Systems: State-of-the-Art and Emerging Technologies," in *Proceedings of the IEEE*, vol. 111, no. 4, pp. 397-420, April 2023, doi: 10.1109/JPROC.2022.3183289.

[7] M. Akil, E. Dokur and R. Bayindir, "Impact of Electric Vehicle Charging Profiles in Data-Driven Framework on Distribution Network," 2021 9th International Conference on Smart Grid (icSmartGrid), pp. 220-225, June 2021.

[8] V. F. Pires, A. Cordeiro, C. Roncero-Clemente, S. Rivera and T. Dragicević, "DC-DC Converters for Bipolar Microgrid Voltage Balancing: A Comprehensive Review of Architectures and Topologies," in *IEEE Journal of Emerging and Selected Topics in Power Electronics*, vol. 11, no. 1, pp. 981-998, Feb. 2023, doi: 10.1109/JESTPE.2022.3208689.

[9] J. Thakur, C. M. L. de Almeida, A. G. Baskar, "Electric vehicle batteries for a circular economy: Second life batteries as residential stationary storage", *Journal of Cleaner Production*, vol. 375, 134066, <https://doi.org/10.1016/j.jclepro.2022.134066>.

[10] S. E. Taha, A. G. Olabi, A. H. Alami, A. Radwan, A. Mdallal, A. Rezk, and M. A. Abdelkareem, "Renewable Energy and Energy Storage Systems" *Energies* 16, no. 3: 1415, 2023. <https://doi.org/10.3390/en16031415>

[11] P. Han, P. Li, X. Xie and J. Zhang, "Coordinated Optimization of Power Rating and Capacity of Battery Storage Energy System with Large-Scale Renewable Energy," 2022 IEEE 6th Conference on Energy Internet and Energy System Integration (EI2), Chengdu, China, 2022, pp. 189-193, doi: 10.1109/EI256261.2022.10116240.

[12] F. Ayadi, I. Colak, I. Garip and H. I. Bulbul, "Impacts of Renewable Energy Resources in Smart Grid," 2020 8th International Conference on Smart Grid (icSmartGrid), Paris, France, 2020, pp. 183-188.

[13] V. F. Pires, A. Cordeiro, "DC Microgrids: Benefits, Architectures, Perspectives and Challenges," *Energies*, vol. 16, 1217, 2023. <https://doi.org/10.3390/en16031217>

[14] N. M. A. A. Shannan, N. Z. Yahaya e B. Singh, "Single-diode model and two-diode model of PV modules: A comparison," 2013 IEEE International Conference on Control System, Computing and Engineering, pp. 210-214, 2013.

[15] A. Belkaid, I. Colak, K. Kayisli, M. Sara and R. Bayindir, "Modeling and Simulation of Polycrystalline Silicon Photovoltaic Cells," 2019 7th International Conference on Smart Grid (icSmartGrid), pp. 155-158, December 2019.

[16] A. Bavand, S. A. Khajehoddin, M. Ardakani and A. Tabesh, "Online Estimations of Li-Ion Battery SOC and SOH Applicable to Partial Charge/Discharge," in *IEEE Transactions on Transportation Electrification*, vol. 8, no. 3, pp. 3673-3685, Sept. 2022, doi: 10.1109/TTE.2022.3162164.

[17] M. T. Lawder et al., "Battery Energy Storage System (BESS) and Battery Management System (BMS) for Grid-Scale Applications," in *Proceedings of the IEEE*, vol. 102, no. 6, pp. 1014-1030, June 2014, doi: 10.1109/JPROC.2014.2317451.

[18] D. Verma, S. Nema, A. M. Shandilya e S. K. Dash, "Maximum power point tracking (MPPT) techniques: Recapitulation in solar photovoltaic systems," *Renewable and Sustainable Energy Reviews*, vol. 54, p. 1018-1034, 2016.

[19] J. P. Ram, T. S. Babu e N. Rajasekar, "A comprehensive review on solar PV maximum power point tracking techniques," *Renewable and Sustainable Energy Reviews*, vol. 67, p. 826-847, 2017.

[20] Ruhi Zafer Caglayan, Korhan Kayisli, Mariacristina Roscia, Abdelhakim Belkaid, Abdelfatah Nasri, "A Comparative Analysis of P&O, IC and Supertwisting Sliding Mode based MPPT methods for PV and Fuel Cell sourced Hybrid System", *International Journal of Renewable Energy Research*, vol. 13, n. 3, pp. 1431-1442, September 2023