

CORTE LONGITUDINAL ENCONTRO E1
(A1-1:100, A3-1:200)

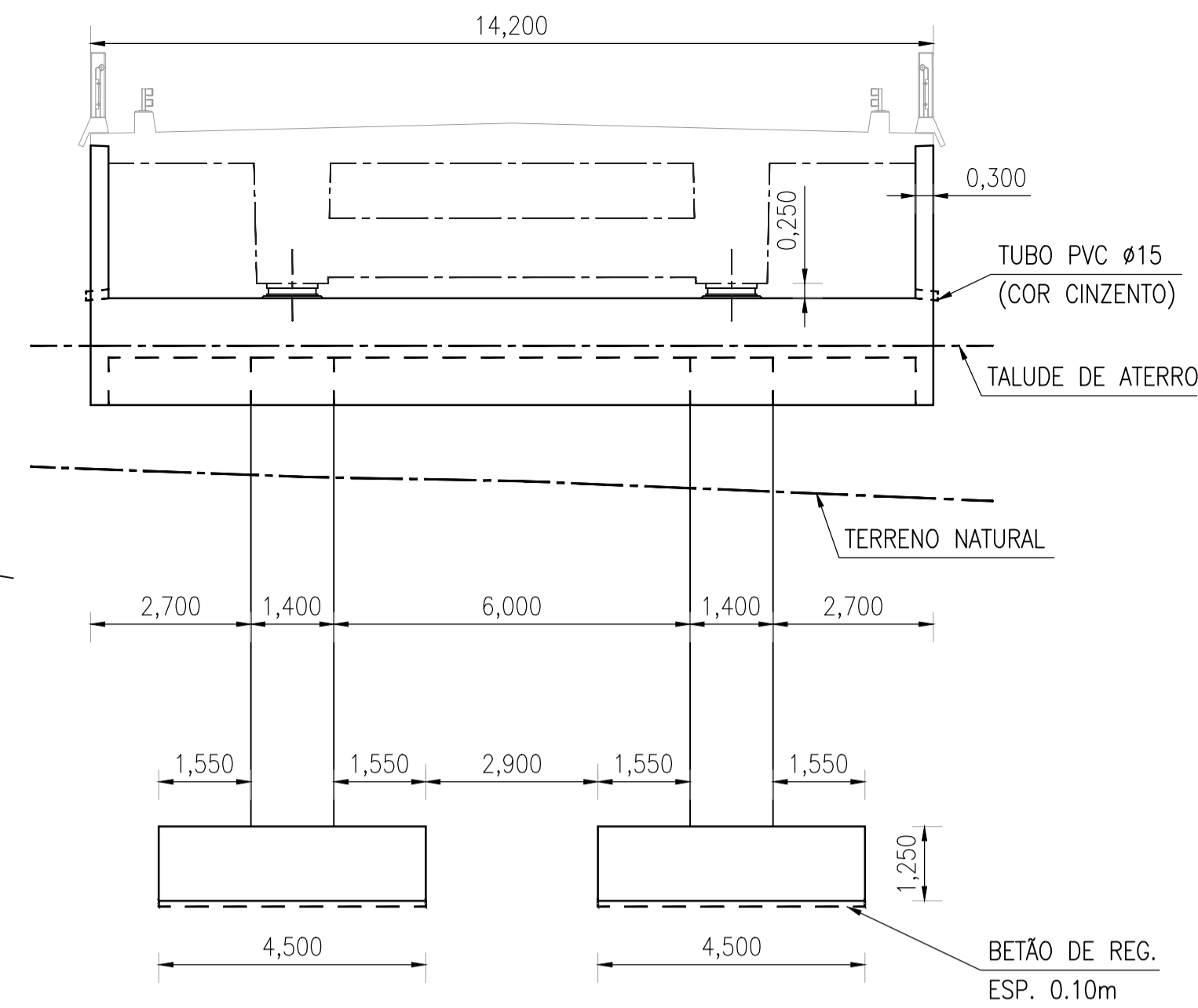

ALÇADO ENCONTRO NORTE
(A1-1:100, A3-1:200)

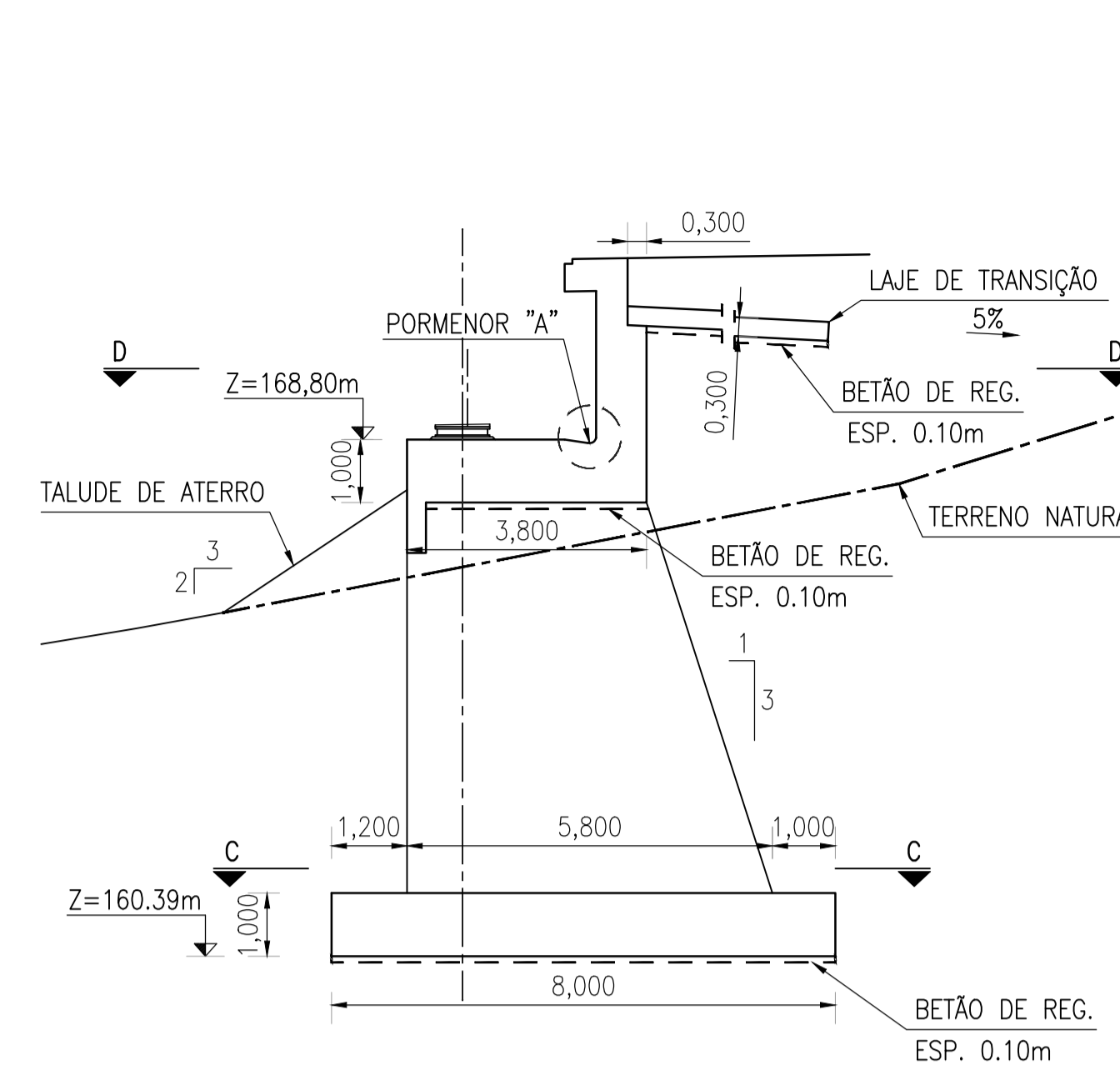

CORTE LONGITUDINAL ENCONTRO E2
(A1-1:100, A3-1:200)

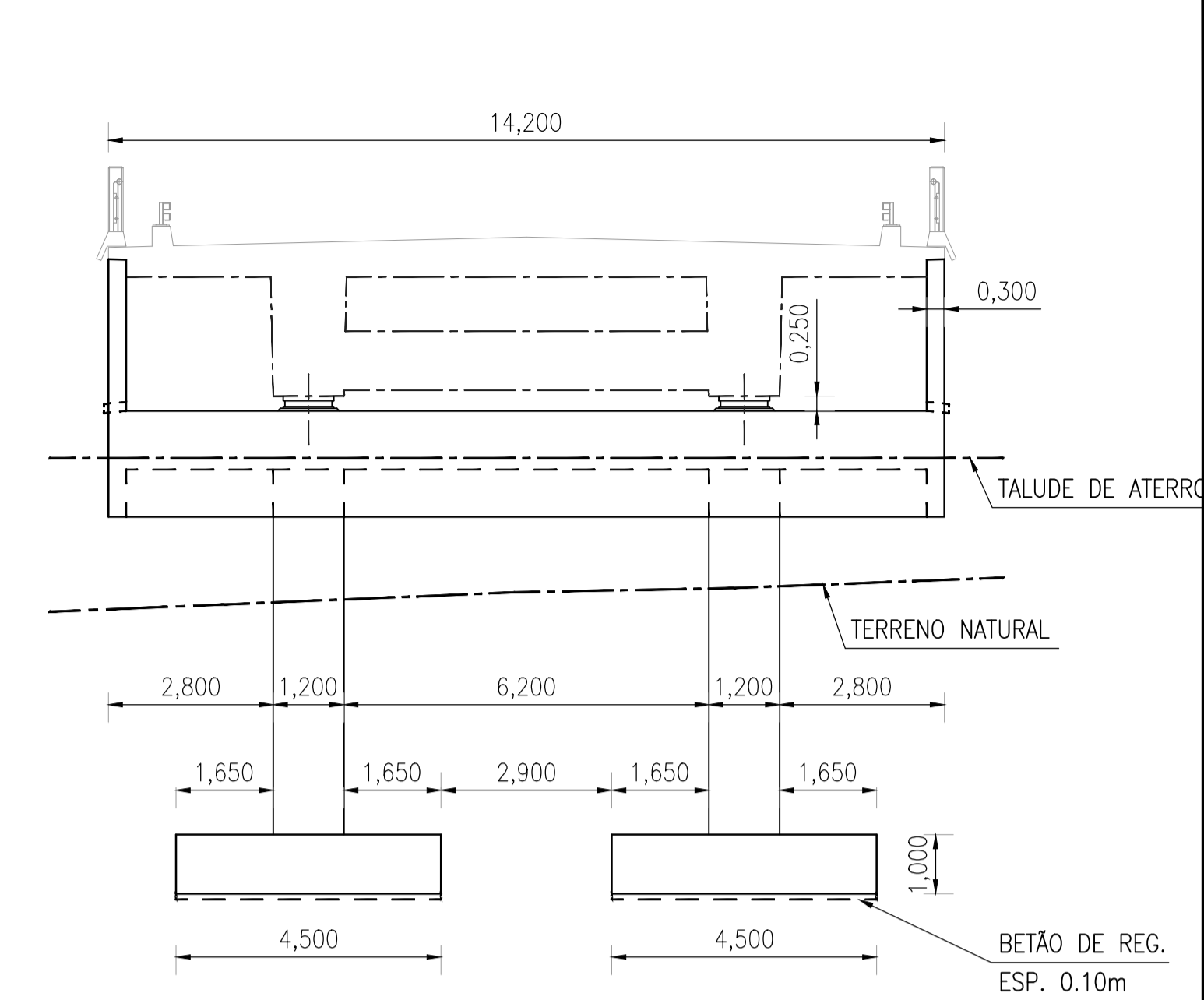

ALÇADO ENCONTRO SUL
(A1-1:100, A3-1:200)

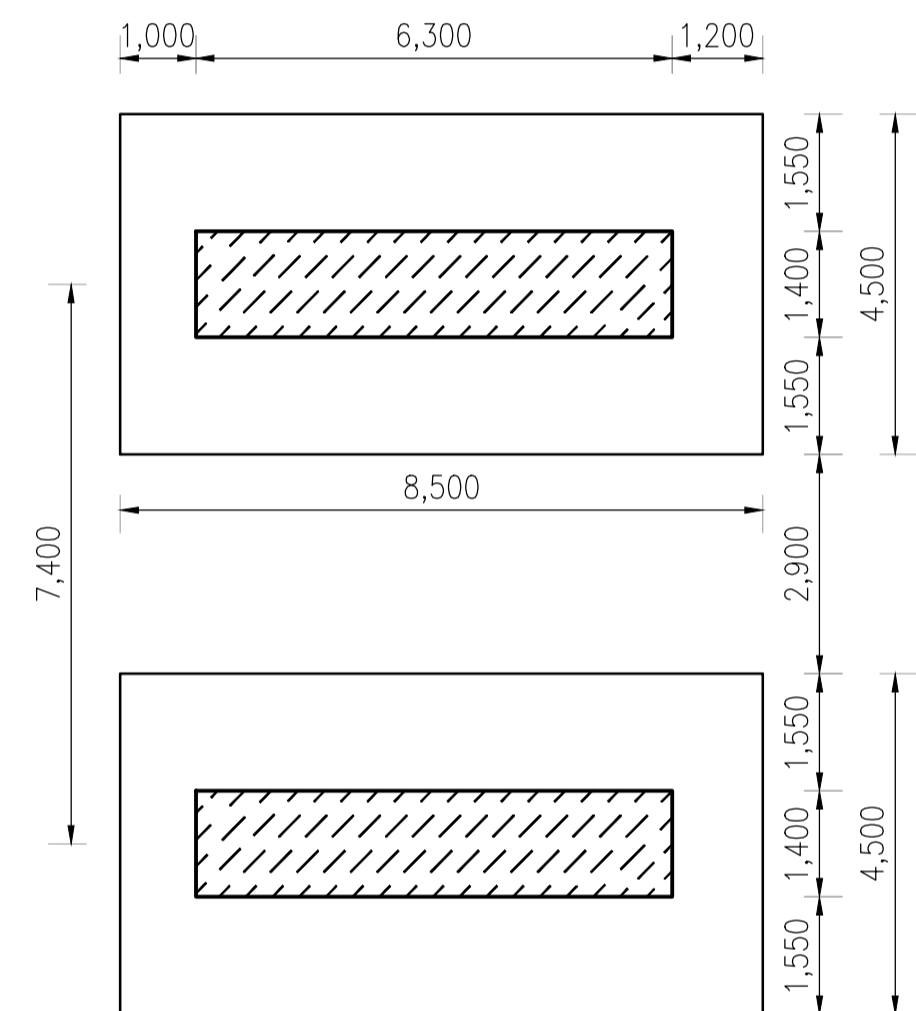

CORTE A-A
(A1-1:100, A3-1:200)

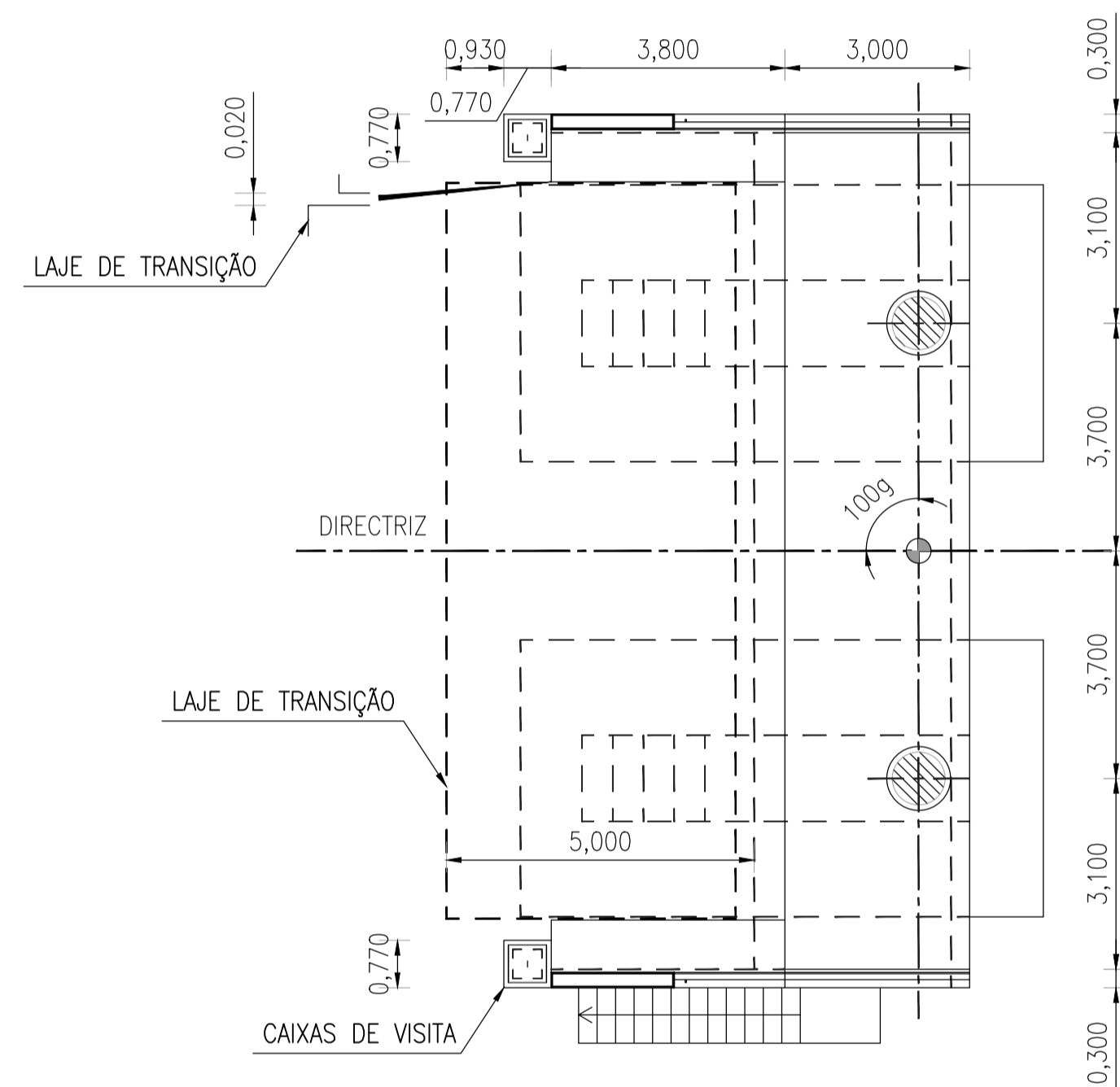

PLANTA ENCONTRO E1
(A1-1:100, A3-1:200)

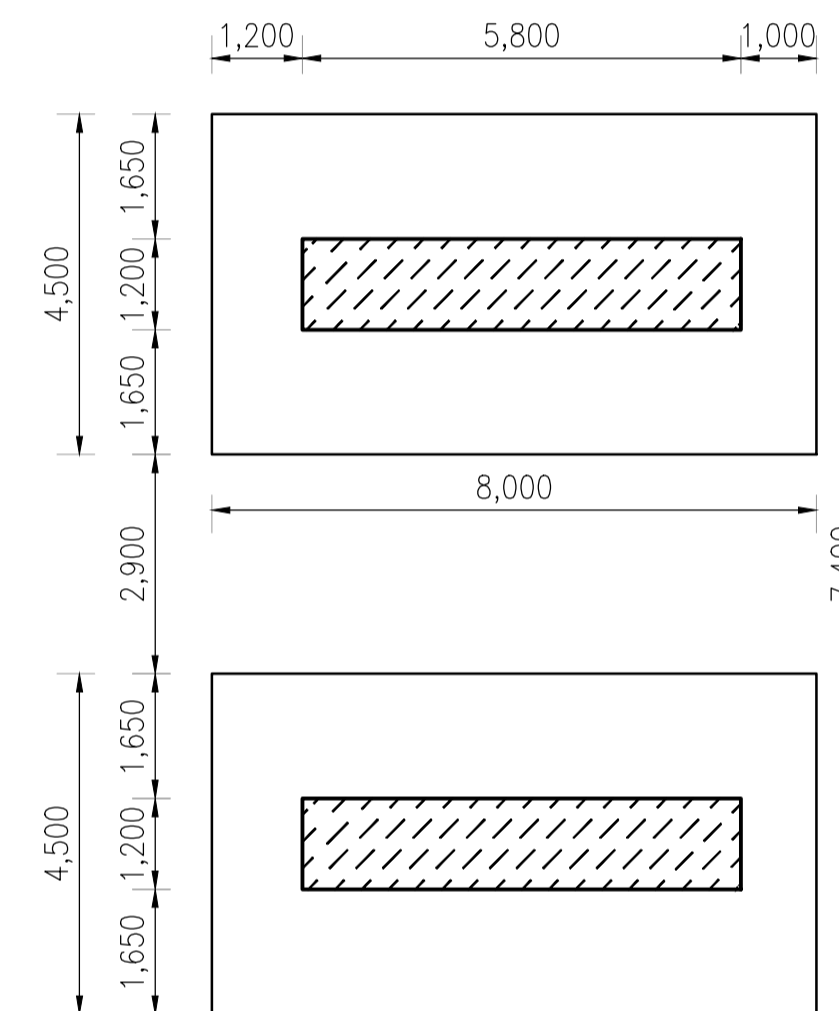

CORTE C-C
(A1-1:100, A3-1:200)

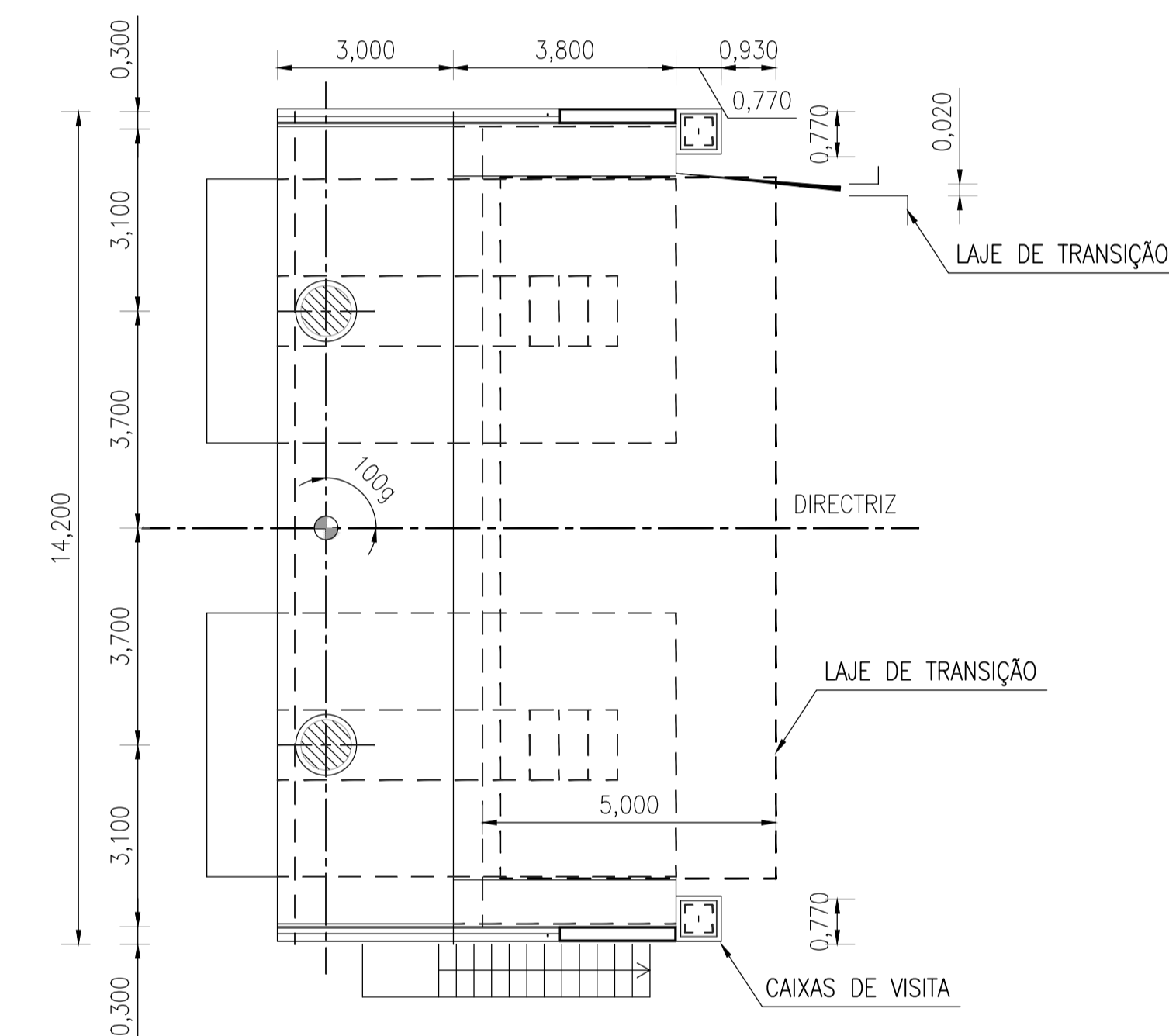

PLANTA ENCONTRO E2
(A1-1:100, A3-1:200)

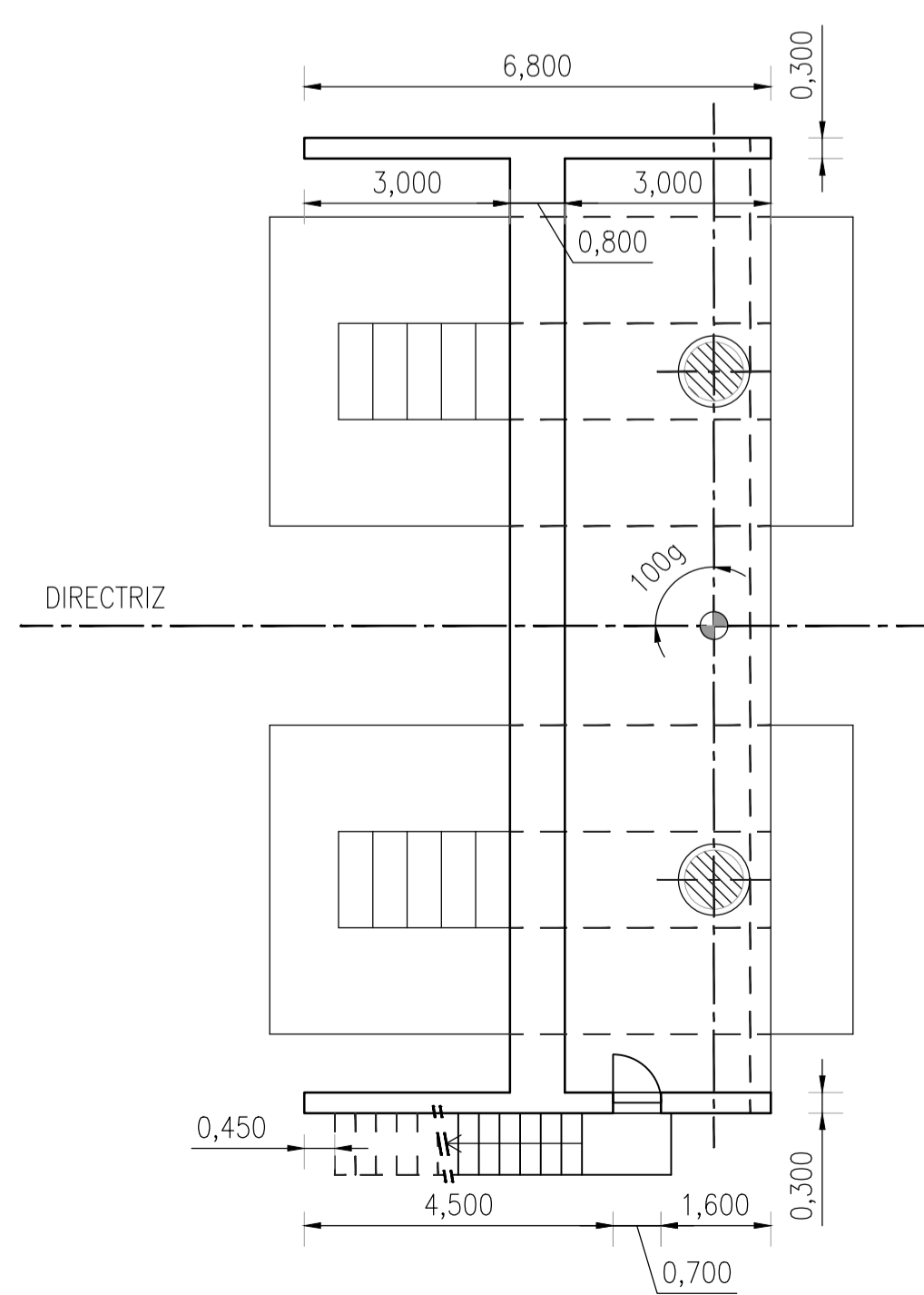

CORTE B-B
(A1-1:100, A3-1:200)

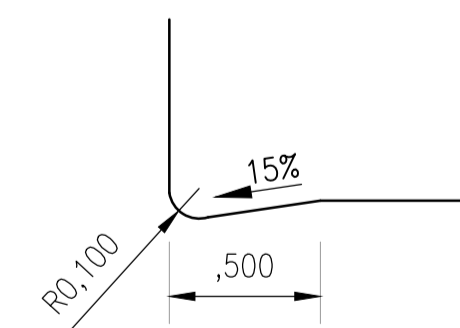

PORMENOR "A"
(A1-1:25, A3-1:50)

ENCONTROS	N _{cp} [kN]	N _{sc} [kN]		N _{dt} [kN]		N _e [kN]		H _t [kN]	δ _{max} ⁺ [mm]	δ _{max} ⁻ [mm]	ex [mm]
		max	min	max	min	max	min				
E1	1300	700	-100	575	-500	5	-5	425	85	160	75
E2	1300	725	-100	575	-500	5	-5	600	85	135	50

ENCONTROS	δ _{max} [mm]		PRÉ-COMPRESSÃO [mm]	LARGURA DA JUNTA [mm]
	+	-		
E1	85	160	75	90
E2	85	135	50	90

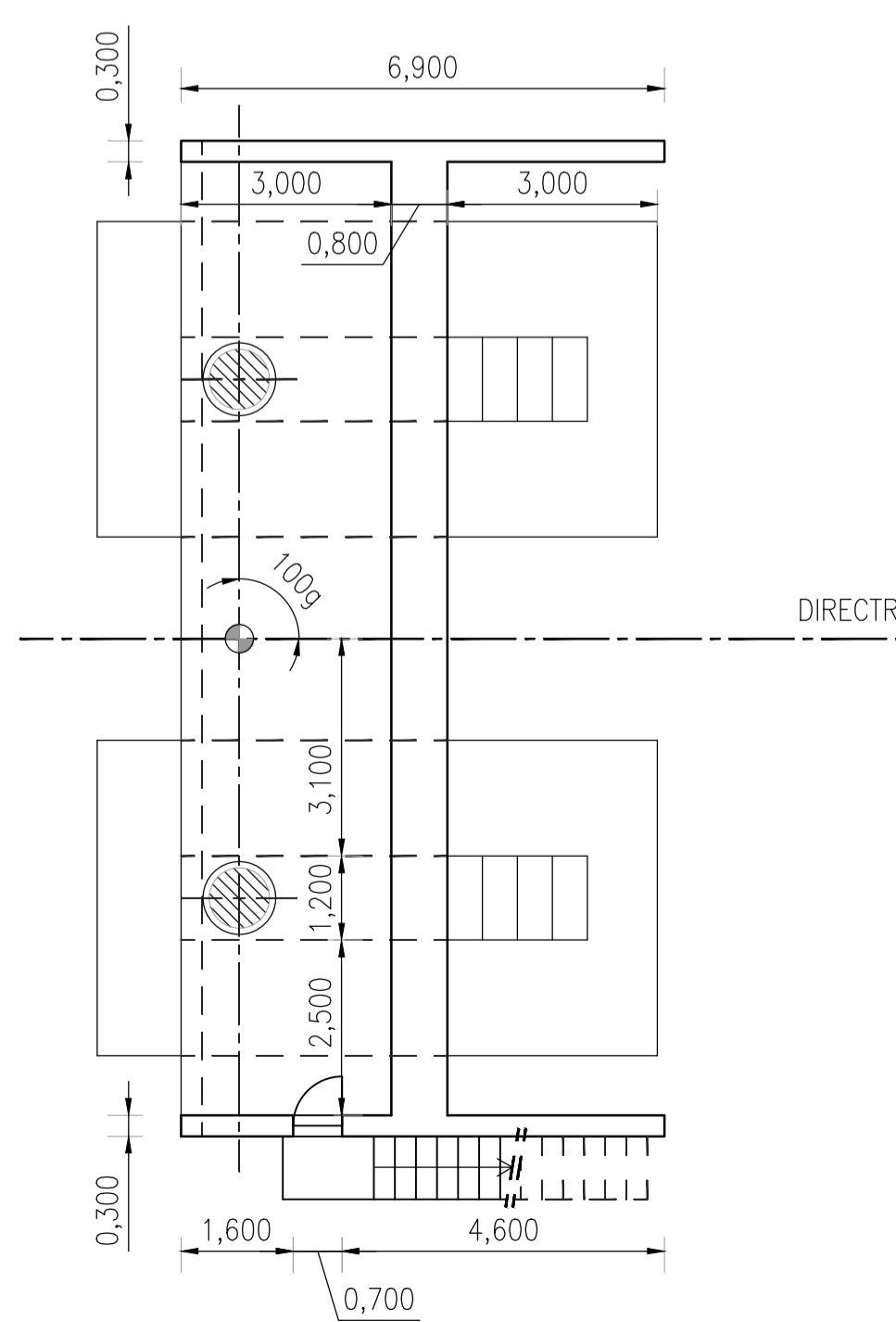

CORTE D-D
(A1-1:100, A3-1:200)

LEGENDA:

N_{cp}, N_{sc}, N_{dt}, e N_e - FORÇA NORMAL AO APOIO DEVIDO ÀS CARGAS PERMANENTES, ÀS SOBRECARGAS, À VARIAÇÃO DE TEMPERATURA E AO SISMO

H_t e H_r - FORÇA HORIZONTAL LONGITUDINAL E HORIZONTAL TRANSVERSAL

δ_{max}⁺ - DESLOCAMENTO MÁXIMO POSITIVO (DILATAÇÃO DO TABULEIRO)

δ_{max}⁻ - DESLOCAMENTO MÁXIMO NEGATIVO (ENCURTAMENTO DO TABULEIRO)

ex - EXCENRICIDADE DA CHAPA SUPERIOR DO APARELHO DE APOIO