

CORTE TRANSVERSAL - PILAR 1
ESC.=1:200

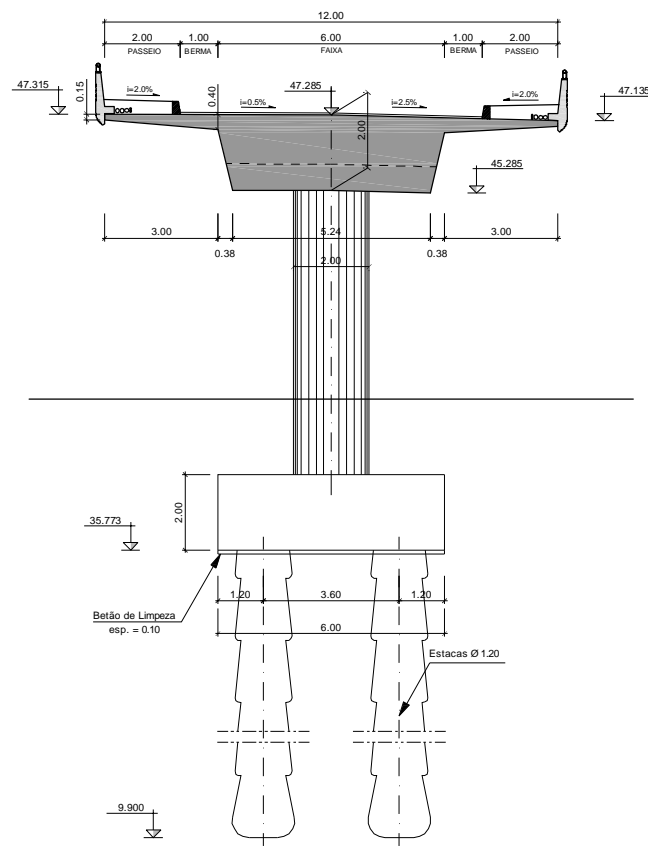

CORTE TRANSVERSAL - PILAR 2
ESC.=1:200

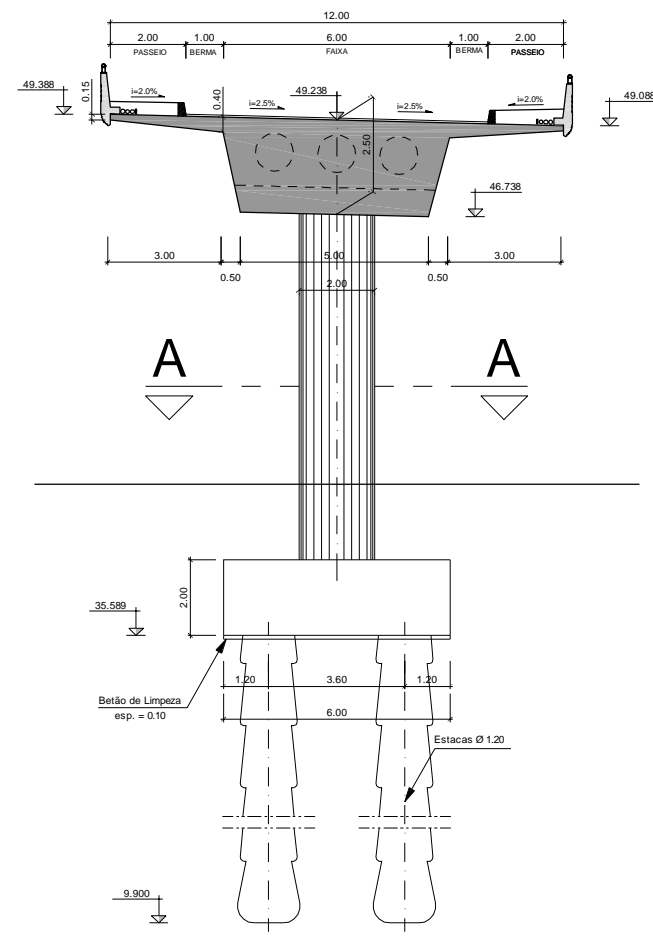

CORTE TRANSVERSAL - PILAR 3
ESC.=1:200

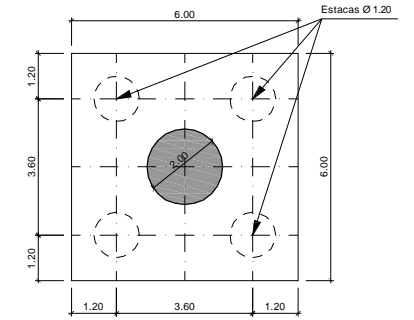

CORTE A - A
ESC.=1:200

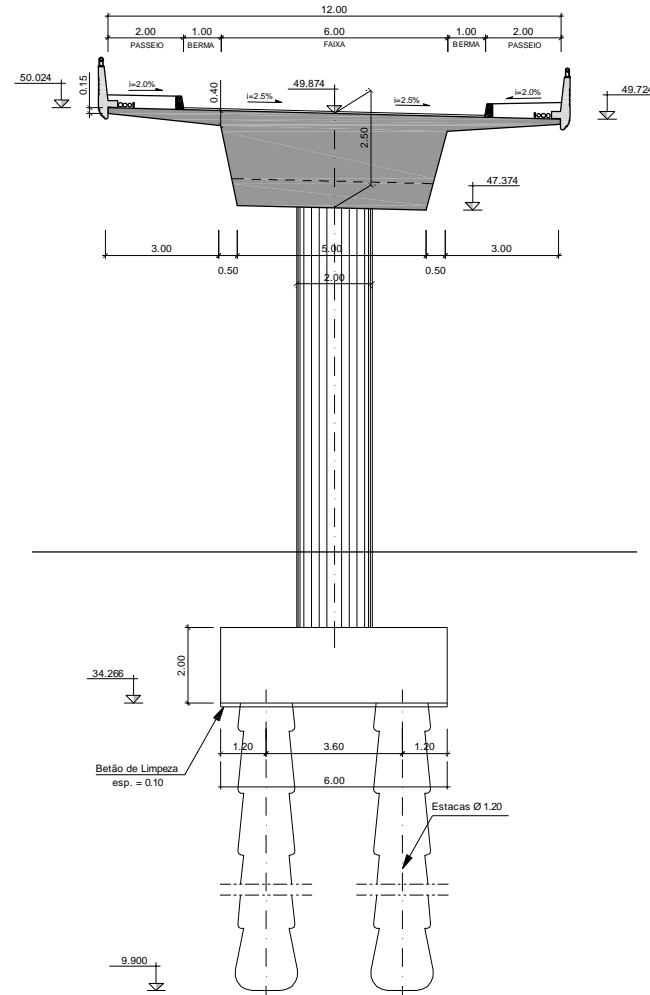

CORTE TRANSVERSAL - PILAR 4
ESC.=1:200

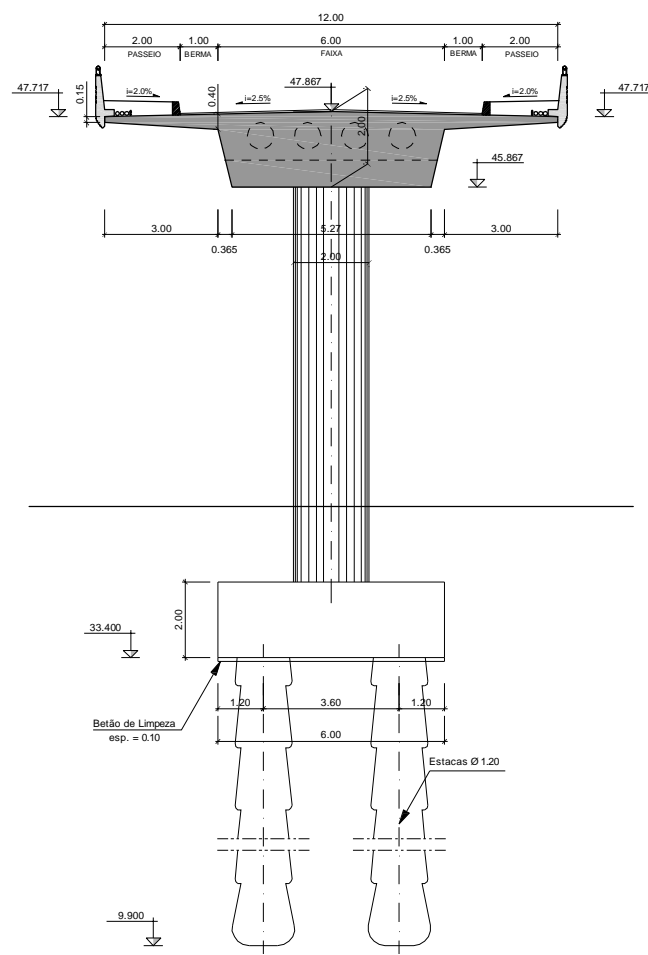

CORTE TRANSVERSAL - PILAR 5
ESC.=1:200

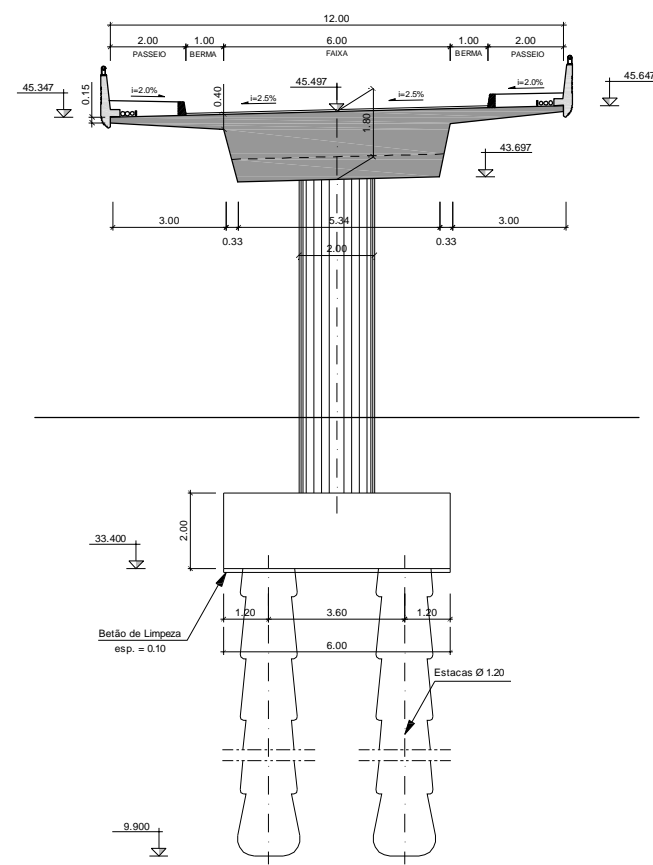

CORTE TRANSVERSAL - PILAR 6
ESC.=1:200

NOTA:
AS COTAS ALTIMÉTRICAS DO TABULEIRO
ASSINALADAS NOS CORTES TRANSVERSAIS
SÃO NO TABULEIRO