



eco-ATC

EVAPORATIVE CONDENSERS



NEW

FEATURING

Ellipti-fin™ COIL

HEAT TRANSFER
TECHNOLOGY



Available with Optional

Pulse-Pure

Water Treatment System

ENVIRONMENTALLY CONSCIOUS OPERATION

Available in Capacities from 125 to 2,900 Ammonia Tons!



IARW International Association of Refrigerated Warehouses

Member of
iilar
International Institute of Ammonia Refrigeration
www.iilar.org

AHRI Air-Conditioning, Heating, and Refrigeration Institute



eco-ATC Design and Construction Features

The eco-ATC line of evaporative condensers represents EVAPCO's newest advancement in thermal heat transfer research and development. Utilizing the **Ellipti-fin™** heat transfer coil, the eco-ATC offers improved heat transfer during wet operation and offers significant water savings due to extended periods of dry operation. The eco-ATC is another chapter in EVAPCO's on-going commitment to quality, environmentally friendly products.

Ellipti-fin™ Heat Transfer Technology

- Thermal Pak® coil with extended surface.
- Water savings through extended periods of dry operation.
- High heat transfer efficiency.
- Low refrigerant charge.

G-235 Mill Hot-Dip Galvanized Steel Construction

(Stainless steel available as affordable option)



PVC Spray Distribution Header with ZM® II Nozzles

- Large orifice nozzles prevent clogging (no moving parts).
- Redesigned nozzles for superior water distribution.
- Nozzles are threaded into header at proper orientation.
- Fixed position nozzles require zero maintenance.
- Threaded end caps for ease of cleaning.
- Guaranteed for life.



Water Saver Drift Eliminators

- Patented design reduces drift rate to 0.001%.
- Made from corrosion resistant PVC for long life.

U.S. Patent No. 6,315,804



Non-Chemical Water Treatment (optional)

- Scale, corrosion and bacteria control.
- Factory mounted with single source responsibility.
- Environmentally safe, chemical-free water treatment.

Totally Enclosed Pump Motors

- Help assure long, trouble-free operation.



Stainless Steel Strainer

- Resists corrosion better than other materials.



Super Low Sound Fan (optional)

- 9-15 dB(A) sound reduction.
- Extremely wide chord fan blades for sound sensitive applications.
- One piece molded heavy duty construction.

Advanced Drive System Design

- Totally Enclosed Fan Motors assures Long Life.
- Power-Band Belts for Better Lateral Rigidity.
- Advanced Design Aluminum Fan Blades.
- Non-corroding Cast Aluminum Sheaves.
- Heavy-Duty Fan Shaft Bearings with L-10 Life of 75,000 - 135,000 hrs.
- All Other Components Corrosion Resistant Materials.
- All Components Covered by 5 Year Warranty.



Easy to Service Motor Mount Design

- All normal maintenance can be performed quickly from outside the unit.
- Designed for easy belt adjustment.
- Extended lube lines for easy bearing lubrication.
- If required, motor may swing to outside for easy removal.



Unique Field Seam

- Eliminates up to 66% of fasteners.
- Self guiding channels improve quality of field seam to eliminate leaks.
- Easy to install.
- Lower installation cost.

Air Inlet Access Door (Optional)

- Increased ease of access to basin.
- Hinged access panel with quick release mechanism.
- Not available on all models.



WST Air Inlet Louvers (Water and Sight Tight)

- Easily removable for access.
- Design keeps sunlight out – preventing biological growth.
- Keeps water in while keeping dirt and debris out.



“Clean Pan” Basin Design

- Access from all four sides.
- Large open area simplifies maintenance.
- Basin may be inspected with pumps running.
- Sloped basin design prevents sediment buildup, biological film and standing water.



Since its founding in 1976, EVAPCO, Incorporated has become an industry leader in the engineering and manufacturing of quality heat transfer products around the world. EVAPCO's mission is to provide first class service and quality products for the following markets:

- Industrial Refrigeration
- Commercial HVAC
- Industrial Process
- Power

EVAPCO's powerful combination of financial strength and technical expertise has established the company as a recognized manufacturer of market-leading products on a worldwide basis. EVAPCO is also recognized for the superior technology of their environmentally friendly product innovations in sound reduction and water management.

EVAPCO is an employee owned company with a strong emphasis on research & development and modern manufacturing plants. EVAPCO has earned a reputation for technological innovation and superior product quality by featuring products that are designed to offer these operating advantages:

- Higher System Efficiency
- Environmentally Friendly
- Lower Annual Operating Costs
- Reliable, Simple Operation and Maintenance

With an ongoing commitment to Research & Development programs, EVAPCO provides the most advanced products in the industry – **Technology for the Future, Available Today!**



EVAPCO products are manufactured in 17 locations in 8 countries around the world and supplied through a sales network consisting of over 170 offices.

Ellipti-fin™ Heat Transfer Coil

Evolution of Heat Transfer Technology

EVAPCO has a long standing commitment to heat transfer research and development. This commitment has resulted in a number of advancements in heat transfer coil design. Up until the mid-1980's, evaporative condensers were manufactured

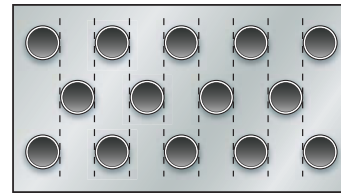

Round Tube Coil by Others

with tightly packed round tube coils. Through thousands of hours of testing and research, EVAPCO developed the Thermal Pak® coil. The Thermal Pak® coil was patented in 1987 and changed the thinking of system design engineers by changing the shape of the coil tubes. The elliptical tube design maximized the effective tube surface area while lowering airside pressure drop and allowing for higher water loading. The combination of the elliptical shape tube in the Thermal Pak® orientation increased heat transfer efficiency and resulted in

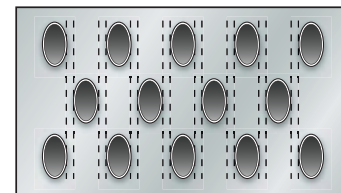

Thermal-Pak® Coil by EVAPCO

the most capacity per plan area of any evaporative condenser on the market.

Throughout the late 1980's and into the 1990's EVAPCO was continuously looking for ways to improve heat transfer efficiency. This research resulted in the development of the Thermal Pak® II heat transfer coil. The Thermal Pak® II coil utilized the same elliptical shape tube introduced in the original Thermal Pak coil, but changed the orientation of the tubes to improve the tubes air to water interface for increased heat transfer efficiency.

The development of the Thermal Pak® II coil resulted in a reduction in refrigerant charge as well as a reduction in operating weight through reduced coil volume while maintaining the same thermal performance as the original Thermal Pak® coil design.

NEW
Ellipti-fin™ Heat Transfer Coil

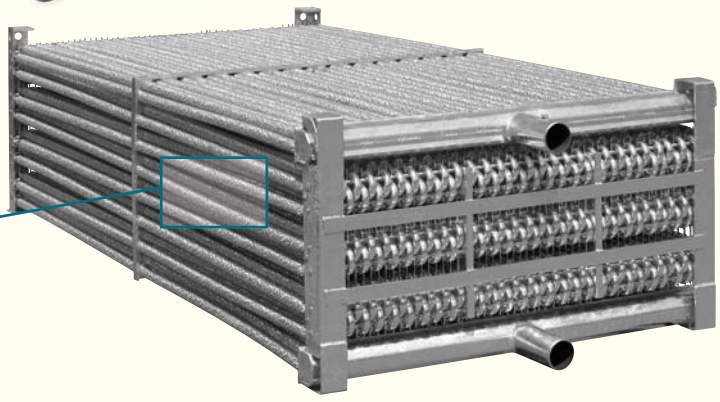
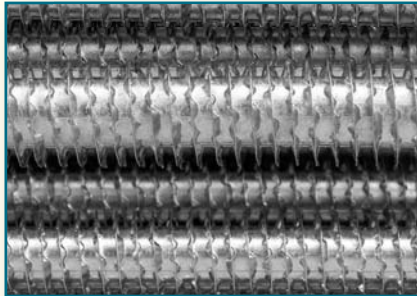

- Elliptical Tubes with Spiral Wound Fins
- Improved Dry and Wet Operation
- All Rows Finned

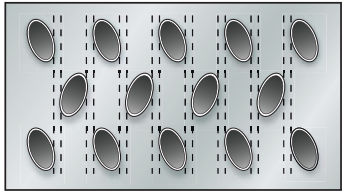

Thermal-Pak® II Coil by EVAPCO

Research and development is an on-going process at EVAPCO. Through the success of the Thermal Pak II coil, EVAPCO saw the potential for new coil configurations and the need for new manufacturing technology to improve processes and efficiency. During this same time, it became evident that a need exists for more environmentally conscious evaporative cooling products.

EVAPCO used the experience gained through the development of the Thermal Pak and Thermal Pak II heat transfer coils and combined with new manufacturing procedures to develop the **Ellipti-fin™** heat transfer coil. The **Ellipti-fin™** coil utilizes elliptical shape tube with extended surface fins for maximum heat transfer efficiency. **The extended surface increases the heat transfer efficiency in the evaporative or wet mode as well as the dry mode of operation.**

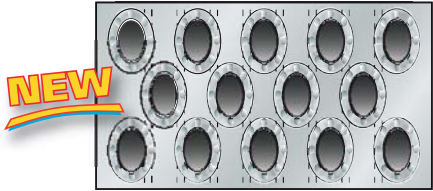

Ellipti-fin™ Finned Elliptical Tube by EVAPCO

The **Ellipti-fin™** coil incorporates features of both the Thermal Pak and Thermal Pak II coils as the tubes are oriented vertically yet spaced so as not to increase the airside pressure drop. As such, eco-ATC condensers are not subject to the performance penalties normally associated with round tube extended surface coils. Additionally, EVAPCO ensures proper evaporative operation by thoroughly wetting the coil surface with the highest water loading in the industry for conventional evaporative condensers.

Ellipti-fin™ coils are manufactured from high quality carbon steel tubing following the most stringent quality control procedures and in accordance with the ASME B31.5 Refrigerant Piping Code. Each circuit is inspected to assure the material quality and tested before fins are wound onto the surface of the tube. Each circuit is then assembled into a complete coil. Finally, the assembled coil is tested at 400 P.S.I.G. air pressure under water to make sure it is leak free. To protect the coil against corrosion, and complete the bond between tube and fin, the entire assembly is dipped in molten zinc (hot dip galvanized) at a temperature of approximately 800°F.

EVAPCO'S new **Ellipti-fin™** condensing coils are designed for maximum heat transfer efficiency. This unique coil design utilizes counterflow heat transfer. The rows of the finned elliptical tubes are positioned vertically in the direction of airflow to enhance turbulence, which increases heat transfer while minimizing airside pressure drop. The design features of EVAPCO's **Ellipti-fin™** condensing coils ensure the end user will receive the highest evaporative heat transfer efficiency wet or dry. These characteristics and other engineering advancements of the **Ellipti-fin™** have been proven in EVAPCO'S world-class research and development laboratory.

eco-ATC Design Features *Proven Performance and Design Flexibility*

Principle of Operation

Evaporative Mode

The refrigerant gas is discharged from the compressor into the inlet connection of the eco-ATC condenser. Water from the condenser's sump is circulated over the condenser coil, while ambient air is simultaneously drawn into the unit. As the ambient air moves up through the coil section, a portion of the spray water is evaporated into the air stream. The evaporative process cools the spray water, which in turn cools the tubes containing the refrigerant gas. The cool tube walls cause the refrigerant gas to give up heat and condense into a liquid. The condensed liquid flows out of the coil to the high pressure liquid receiver for return to the system. The hot, saturated air is drawn through the drift eliminators, where any entrained water droplets are removed. The condenser's fan then discharges this air stream out of the top of the unit at a high velocity, where it can dissipate harmlessly into the atmosphere. The water which was not evaporated falls into the sump and is recirculated by the spray pump to the water distribution system above the condensing coil section.

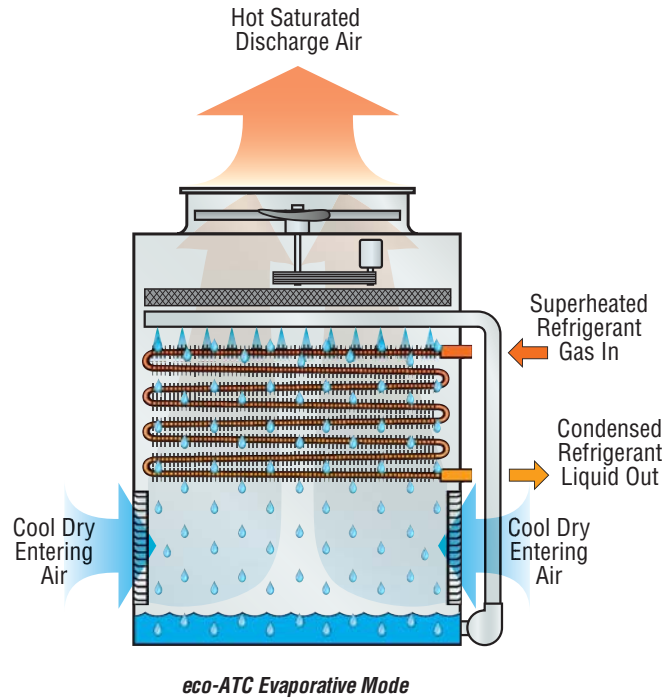

Dry Mode

The refrigerant gas is discharged from the compressor into the inlet connection of the eco-ATC condenser. Ambient air is drawn into the unit and moves over the heat transfer coil. The air is warmed while the tubes containing the refrigerant gas are cooled. The cool tube walls cause the refrigerant gas to give up heat and condense into a liquid. The condensed liquid flows out of the coil to the high pressure liquid receiver for return to the system. The hot discharge air is drawn through the drift eliminators and then the fan then discharges the air stream out of the top of the unit where it can dissipate harmlessly into the atmosphere.

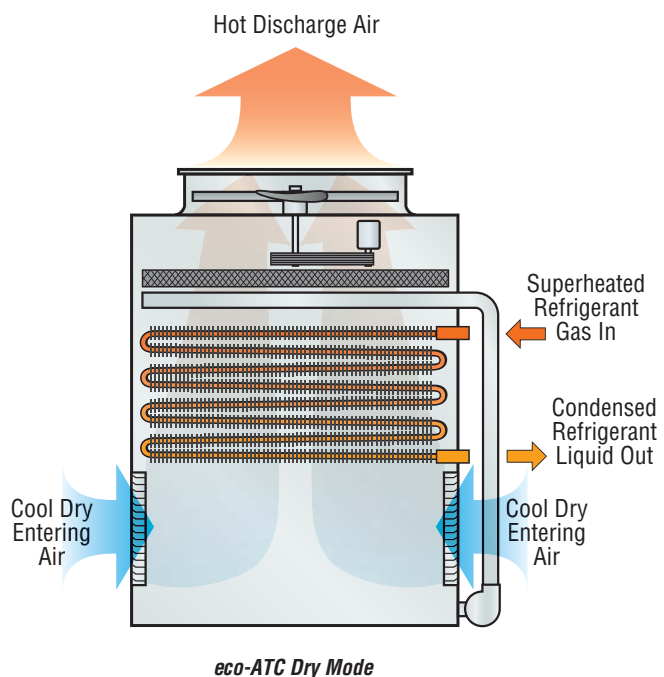

eco-ATC Design Features *Proven Performance and Design Flexibility*

Water and Energy Saving with eco-ATC Technology

Low Fan Motor Hp

The eco-ATC features the new EVAPCO **Ellipti-fin™** coil, which utilizes elliptical spiral fin coil technology. This technology allows for up to 15% increase in thermal performance while offering model selections with reduced fan motor horsepower. This will result in significant energy savings throughout the year.

Reduced Plan Area

Due to the increased thermal performance, new eco-ATC also minimizes the footprint required for a given capacity thereby reducing the space required for an evaporative condenser. A smaller footprint means less steel and lower installation costs.

Significant Water Savings

The **Ellipti-fin™** coil technology enables the eco-ATC to be operated in a 100% Dry Mode at a significantly higher switchover temperature than that of a typical bare tube coil evaporative condenser. This leads to a significant increase in the number of hours per year the condenser can operate in dry mode (spray pumps off), thus increasing your water savings. This combination of features allows the eco-ATC to be operated with both energy and water efficiency in mind, making it the ideal choice for many installations.

Consider a meat processing plant application near Minneapolis, MN where the unit is required to reject a constant heat load of 500 tons of refrigeration at a 95°F condensing temperature and a summer design wet bulb temperature of 76°F. The process operates 24 hours a day 7 days a week. The eco-ATC evaporative condenser and an ATC-E evaporative condenser are compared as follows:

EVAPCO Model	ATC-723E	eco-ATC-702
Plan Area	12' x 18'	12' x 18'
Fan Motor	30 hp	20 hp
Pump Motor	7-1/2 hp	7-1/2 hp

Model Comparison

In the previous example, the eco-ATC model requires lower fan motor horsepower than the equivalent ATC-E while maintaining the same plan area. The potential for reduced hp during wet operation is only one of the eco-ATC benefits. The enhanced dry performance of the eco-ATC can be illustrated by using bin weather data for Minneapolis, MN as shown below.

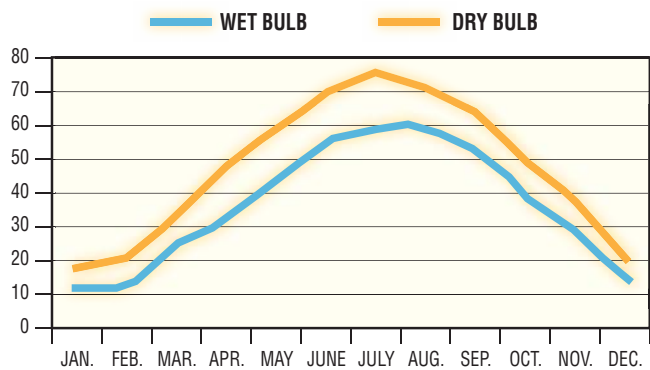

Minneapolis Annual Weather Data

Assuming a load profile requiring full 70% heat rejection requirement for a full time operation of the refrigeration system yields the following comparison between the eco-ATC and the ATC:

EVAPCO Model	ATC-723-1g	eco-ATC-702-1g
Plan Area	12' x 18'	12' x 18'
Fan Motor	30 hp	20 hp
Pump Motor	7-1/2 hp	7-1/2 hp
70% Dry Switchover (°F)	-5°F	35.7°F
% Dry Operation/Year	2%	34%

The above example shows the eco-ATC-702-1g can be operated without spray water 34% of the year while maintaining 70% of the full load capacity. The additional dry operation means less opportunity for freeze-ups, reduced water management costs and reduced water treatment costs.



eco-ATC Design Features *Proven Performance and Design Flexibility*

Construction Features

EVAPCO, long known for using premium materials of construction, has developed the ultimate system for corrosion protection in galvanized steel construction – the EVAPCOAT Corrosion Protection System. Marrying corrosion free materials with heavy gauge mill hot-dip galvanized steel construction to provide the longest life product with the best value.

G-235 Mill Hot-Dip Galvanized Steel Construction

Mill hot-dip galvanized steel has been successfully used for over 40 years for the protection of evaporative condensers against corrosion. There are various grades of mill galvanized steel each with differing amounts of zinc protection. EVAPCO has been a leader in the industry in developing heavier galvanizing, and was the first to standardize on G-235 mill hot-dip galvanized steel.

G-235 designation means there is a minimum of 2.35 ounces of zinc per square foot of surface area as measured in a triple spot test. G-235 is the heaviest level of galvanizing available for manufacturing evaporative condensers and has a minimum of 12% more zinc protection than competitive designs using G-210 steel.

During fabrication, all panel edges are coated with a 95% pure zinc-rich compound for extended corrosion resistance.

Type 304 Stainless Steel Strainers

Subjected to excessive wear and corrosion, the sump strainer is critical to the successful operation of the condenser. EVAPCO uses only stainless steel for this very important component.

Unique Seam Design—Eliminate Field Leaks

The eco-ATC features EVAPCO's unique panel construction design which includes a special butyl tape sealer with an integral sealing gasket. Each joint is then backed with a secondary caulking compound and encased in a double-brake flange for added strength and structural integrity. This unique sealing system has been proven effective in both laboratory tests and years of field application.

Easy Field Assembly

The eco-ATC features a unique field seam design which ensures easier assembly and fewer field seam leaks. The field seam incorporates self-guiding channels to guide the coil casing section into position and set in place on the bottom basin section of the condenser. In addition, the design eliminates up to 66% of the fasteners typically used to join the condenser sections in the field significantly reducing the contractor labor costs for installation.



Improved Maintenance

ZM® II Spray Nozzle Water Distribution System

Even and constant water distribution is paramount for reliable, scale-free evaporative condensing. EVAPCO'S *Zero Maintenance* ZM® II Spray Nozzle remains clog-free under the toughest conditions to deliver approximately 6 GPM to every square foot of coil plan area.

The heavy-duty ABS ZM® II Spray Nozzles have a 1-1/4" diameter opening and a 1-1/4" splash plate clearance. The fixed position ZM® II Spray Nozzles are mounted in corrosion-free PVC water distribution pipes that have threaded end caps. Together, these elements combine to provide unequalled coil coverage, enhanced droplet formation and make the industries best performing maintenance-free water distribution system.



ZM® II Nozzle

Alternate Materials of Construction

EVAPCO induced draft condensers have a modular design which allows for specific areas to be enhanced for increased corrosion protection. For particularly corrosive environments, EVAPCO condensers are available with Stainless Steel construction for the basin, casing and/or coil.

Stainless Steel Basin

The basin area of a condenser is often subjected to high concentrations of impurities and silt. In addition to the EVAPCOAT Corrosion Protection System, EVAPCO offers optional stainless steel construction for superior corrosion resistance. This option provides Type 304 or Type 316 stainless steel for the entire basin section - including the support columns and air inlet louver frames.

“Clean Pan” Basin Design

EVAPCO ATC-E condensers feature a sloped basin from the upper to lower pan section. This “Clean Pan” design allows the water to be completely drained from the basin. The condenser water will drain from the upper section to the depressed lower pan section where the dirt and debris can be easily flushed out through the drain. This design helps prevent buildup of sedimentary deposits, biological films and minimizes standing water.

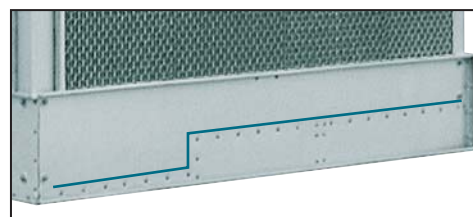

eco-ATC Design Features *Proven Performance and Design Flexibility*

Belt Drive Units – 8-1/2’ & 17’ Wide Models

The fan motor and drive assembly on these units is designed to allow easy servicing of the motor and **adjustment of the belt tension from the exterior of the unit**. A T.E.F.C. fan motor is mounted on the outside of these models. A protective cover swings away to allow servicing and belt adjustment. A large hinged access door with a “quick release” latch provides access to the fan section for maintenance.



*External Motor Mount
(with optional ladder)*

Belt Drive Units – 10’, 12’ & 24’ Wide Models

The fan motor and drive assembly is designed to allow easy **servicing of the motor and adjustment of the belt tension from the exterior of the unit**. The T.E.A.O. fan motor is located inside the fan casing on a rugged heavy duty motor base. The innovative motor base also features a unique locking mechanism for a positive adjustment.



Motor Base Assembly

The motor base is designed to swing out through a very large, 14 square foot access opening. This allows for easy servicing of the motor.

Drive System

Inverter Duty Motors: Inverter Duty Motors are standard on ATC-E condensers. Inverter Duty motors are totally enclosed premium efficiency and inverter capable (VFD by others).

Note: Variable Frequency Drive control may require other component modification such as motor shaft grounding brushes, AC load reactors, low pass filters and tuned trap filters to ensure proper motor performance and service life.

Power- Band Drive Belt: The Power-Band is a solid-back, multigroove belt system that has high lateral rigidity. The proven drive system is used on 8’ wide and wider models. The belt is constructed of neoprene with polyester cords. The drive belt is designed for minimum 150% of the motor nameplate horsepower for long life and durability.

Fan Shaft Bearings: The fan shaft bearings in ATC-E units are specially selected for long, trouble-free life. They are rated for an L-10 life of 75,000 to 135,000 hours and are the heaviest pillow block bearing available.

Aluminum Alloy Sheaves: Fan sheaves are constructed of corrosion free aluminum for long life, eliminating the corrosion that occurs on cast steel sheaves, thereby extending belt life.

Five Year Drive Warranty: All drive components on ATC-E units are covered by EVAPCO’s exclusive 5 year drive warranty - including fan motors and belts!

Superior Water Saver Drift Eliminators

An extremely efficient drift eliminator system is standard on EVAPCO condensers. The patented system removes entrained water droplets from the air stream to limit the drift rate to less than 0.001% of the recirculating water rate. The drift eliminators are constructed of an inert polyvinyl chloride (PVC) plastic material which effectively eliminates corrosion of these vital components. They are assembled in sections to facilitate easy removal for inspection of the water distribution system.



Water Saver Drift Eliminator

Superior WST Air Inlet Louver Design

EVAPCO’S WST Inlet Louvers keep water in and sunlight out of the basins of induced draft products. The unique non-planar design is made from light-weight PVC sections which easily fit together and have no loose hardware, enabling easy basin access. (Patent Pending)



Inlet Louver Design

Developed with computational fluid dynamics (CFD) software and tested in EVAPCO’s R&D center, the louver’s air channels are optimized to maintain fluid dynamic and thermodynamic efficiency and block all line-of-sight paths into the basin eliminating splash-out; even when the fans are off. Additionally, algae growth is minimized by blocking all sunlight.

The combination of easy basin access, no splash-out and minimized algae growth saves the end user money on maintenance hours, water consumption and water treatment costs.

Air Inlet Access Door (Optional)

To aid in basin maintenance, eco-ATC models can be equipped with an optional air inlet access door. This feature improves the maintainability of the condenser by allowing easy access to the make-up float assembly and strainer for inspection without removing an entire inlet louver.

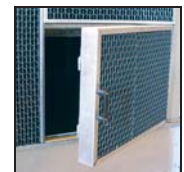

IBC Compliance

IBC Compliance

EVAPCO has been applying advanced structural technology to evaporative condensers for many years. Following seismic events in the mid 1990's EVAPCO introduced the UB Series of induced draft cooling towers, fluid coolers and evaporative condensers. These products were designed, built and independently certified for extreme seismic and wind forces. With the advent of the International Building Code, EVAPCO is now offering a new line of eco-ATC Evaporative Condensers that is IBC 2006 compliant as standard construction.

International Building Code

The International Building Code (IBC) is a comprehensive set of regulations addressing the structural design and installation requirements for building systems – including HVAC and industrial refrigeration equipment. As of June 2008, all 50 states plus Washington D.C have adopted the International Building Code. Compared to previous building codes that solely examined anchorage, the earthquake provisions contained within the International Building Code address anchorage, structural integrity, and operational capability of a component following a seismic event. The goal of the IBC is to minimize the loss of life and improve the capability of essential facilities to operate after a seismic event.

The International Building Code (IBC) was developed to replace the *BOCA National Building Code*, ICBO's *Uniform Building Code* and SBCCI's *Standard Building Code*. The International Building Code specifies that all components be designed to resist the equivalent seismic forces as the structure to which they are installed whereas previous building codes focused exclusively on the structure of the building to provide resistance against seismic forces. These components include all aspects of the building architectural, electrical and mechanical systems. The failure of these components during a seismic event has been a common occurrence in recent history. Although the structure of the building may be relatively undamaged from an earthquake, the damage to the nonstructural components could be significant and result in considerable secondary damage to the building (ie. flooding, fire, structural damage).

Seismic Design

The IBC specifies that all installed components must meet the requirements of ASCE 7-05 (American Society of Civil Engineers, *Minimum Design Loads for Buildings and Other Structures*). Exemptions noted in the code are for all mechanical components assigned to seismic design categories A or B. ASCE 7-05 explicitly states that in addition to the attachment and supports, the component itself must be designed to withstand the seismic

forces prescribed in the code. Simply stated, the code provisions require that evaporative cooling equipment and all other components permanently installed on a structure must meet the same seismic design criteria as the building.

The seismic design force, utilized for component design, represents an equivalent static force that is applied to the components' center of gravity as described in the following equation:

$$F_p = [(0.4 * (a_p) * (S_{DS}) * (W_p)) / (R_p / I_p)] * (1 + 2 * (z / h))$$

F_p = Seismic Design Force centered at the component's center of gravity

S_{DS} = Design spectral response acceleration, short period

a_p = Component amplification factor

I_p = Component importance factor

W_p = Component operating weight

R_p = Component response modification factor

z = Height in structure of point of attachment of component with respect to the base

h = Average roof height of structure with respect to the base

The minimum and maximum design force limits are specified as:

$$F_{p-min} = 0.3 SDS I_p W_p$$

$$F_{p-max} = 1.6 SDS I_p W_p$$

A series of charts and graphs are used to determine the appropriate factors based on the location of the installation and ultimately the "importance" of the facility. A chart of the potential seismic activity in the United States is shown below.

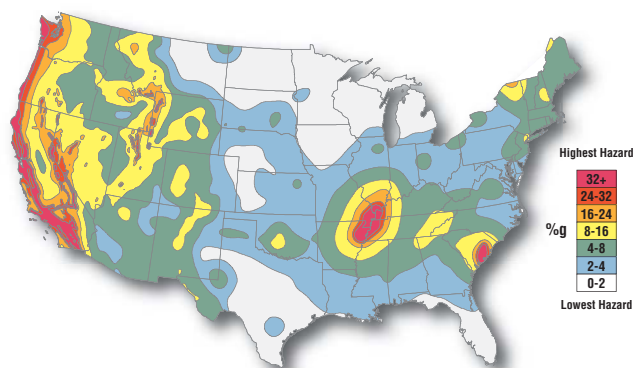

Map courtesy US Geological Survey website

IBC Compliance

Importance Factor (Ip)

A major parameter that must be determined prior to calculating the seismic design force is the component importance factor (Ip). ASCE 7-05 defines the component importance factor as:

Importance Factor, Ip	Classification
1.5	<ul style="list-style-type: none"> Life safety component required to function after seismic event. Component containing hazardous content Components installed at Group III (essential) facilities
1.0	All other components

Products such as ammonia refrigerant condensers should always be assigned an importance factor of 1.5 since they contain ammonia. The IBC identifies ammonia as hazardous content in reference of OSHA standards. According to the American Society of Civil Engineers (ASCE) Manual, 07-05 edition, section 13.1.3, hazardous materials require an importance factor of 1.5.

Design Implementation

In order to achieve this goal, an architect or civil engineer is responsible for analyzing the soil and the design of a structure to determine the factors to be used. A mechanical consulting engineer and/or design build contractor applies these factors to advise the manufacturer on the proper design for the application. EVAPCO takes this information and determines the necessary equipment to meet IBC regulations. EVAPCO then determines the condenser design requirements based on the IBC criteria. The standard eco-ATC design is independently certified to meet the 1g IBC compliance factors. Contact the factory for applications that require a more severe seismic duty. This process ensures that the mechanical equipment and its components are seismically compliant per the provisions of the International Building Code.

Independent Certification

As required by the International Building Code, EVAPCO supplies a certificate of compliance as part of its submittal documents. The certificate of compliance should demonstrate that the equipment/unit has been independently tested and analyzed in accordance with the IBC program. EVAPCO has worked closely with Vibrations Mountings and Controls Group (VMC) to complete the independent equipment testing and analysis. A sample of the certificate of compliance and unit label is presented below:

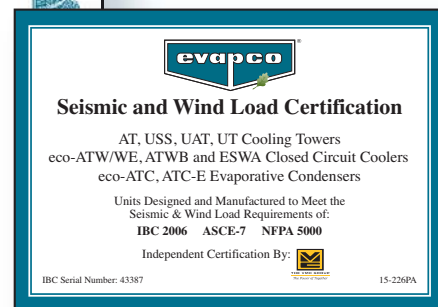



Engineering Dimensions & Data

Models eco-ATC-176-1g to 272-1g

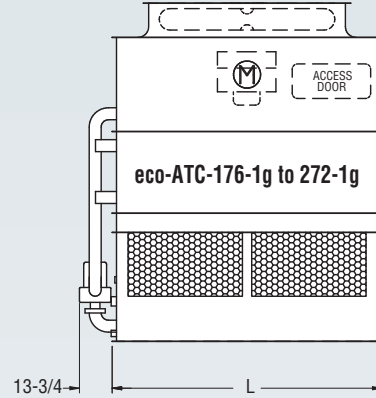
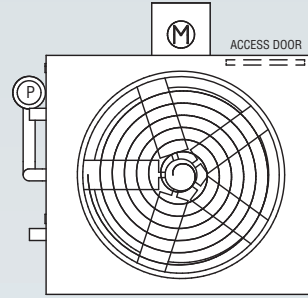
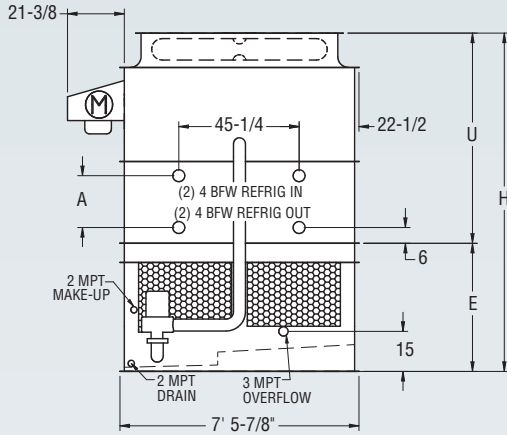

Table 1 Engineering Data

Model No.	R-717 Tons*	Fans		Weights†			Refrigerant Operating Charge lbs.***	Coil Volume ft ³	Spray Pump		Remote Pump		Dimensions					
		HP	CFM	Shipping	Heaviest Section†	Operating			HP	GPM	Gallons Req'd**	Conn. Size	Operating Weight	Height H	Upper U	Lower E	Coil A	Length L
eco-ATC-176-1g	125	3	25,100	9,310	8,010	11,890	183	25	2	340	220	8"	10,790	11' 2-3/4"	7' 2-1/2"	4' 1/4"	27"	8' 5-1/2"
eco-ATC-179-1g	127	5	30,600	7,980	6,680	10,470	141	19	2	340	220	8"	9,370	10' 7-1/4"	6' 7"	4' 1/4"	19-1/2"	8' 5-1/2"
eco-ATC-196-1g	140	7.5	35,000	8,030	6,730	10,520	141	19	2	340	220	8"	9,420	10' 7-1/4"	6' 7"	4' 1/4"	19-1/2"	8' 5-1/2"
eco-ATC-197-1g	140	5	29,700	9,320	8,020	11,900	183	25	2	340	220	8"	10,800	11' 2-3/4"	7' 2-1/2"	4' 1/4"	27"	8' 5-1/2"
eco-ATC-209-1g	149	10	38,400	8,040	6,740	10,530	141	19	2	340	220	8"	9,430	10' 7-1/4"	6' 7"	4' 1/4"	19-1/2"	8' 5-1/2"
eco-ATC-216-1g	154	7.5	34,000	9,370	8,070	11,950	183	25	2	340	220	8"	10,850	11' 2-3/4"	7' 2-1/2"	4' 1/4"	27"	8' 5-1/2"
eco-ATC-227-1g	161	7.5	33,000	10,800	9,500	13,460	226	31	2	340	220	8"	12,360	11' 10-1/4"	7' 10"	4' 1/4"	34-1/2"	8' 5-1/2"
eco-ATC-230-1g	164	10	37,200	9,380	8,080	11,960	183	25	2	340	220	8"	10,860	11' 2-3/4"	7' 2-1/2"	4' 1/4"	27"	8' 5-1/2"
eco-ATC-241-1g	171	10	36,100	10,810	9,510	13,470	226	31	2	340	220	8"	12,370	11' 10-1/4"	7' 10"	4' 1/4"	34-1/2"	8' 5-1/2"
eco-ATC-251-1g	179	10	35,000	12,220	10,920	14,960	269	37	2	340	220	8"	13,860	12' 5-3/4"	8' 5-1/2"	4' 1/4"	42"	8' 5-1/2"
eco-ATC-261-1g	186	15	40,500	10,940	9,640	13,600	226	31	2	340	220	8"	12,500	11' 10-1/4"	7' 10"	4' 1/4"	34-1/2"	8' 5-1/2"
eco-ATC-272-1g	193	15	39,200	12,350	11,050	15,090	269	37	2	340	220	8"	13,990	12' 5-3/4"	8' 5-1/2"	4' 1/4"	42"	8' 5-1/2"

* Tons at standard conditions: 96.3°F condensing, 20°F suction and 78°F W.B.

** Gallons shown is water in suspension in unit and piping. Allow for additional water in bottom of remote sump to cover pump suction and strainer during operation. (12" would normally be sufficient.)

† Heaviest section is the coil section. **Weights shown are for 1g seismic design.**

*** Refrigerant charge is shown for R-717. Multiply by 1.93 for R-22 and 1.98 for R-134a.

Dimensions are subject to change. Do not use for pre-fabrication. Quantity of coil connections subject to change based on refrigerant and design conditions.

Engineering Dimensions & Data

Models *eco-ATC-226-1g* to *334-1g*

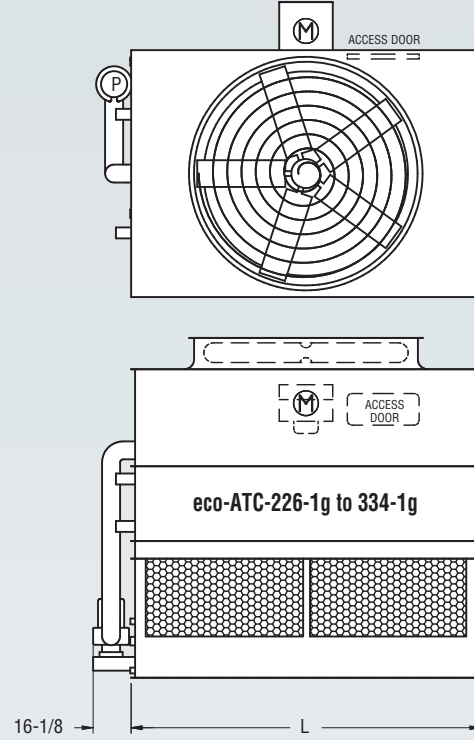
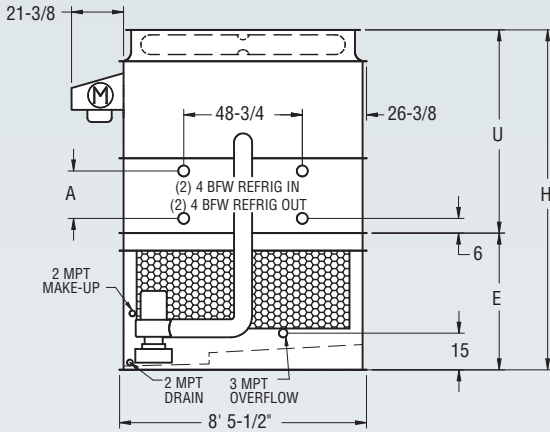

Table 2 Engineering Data

Model No.	R-717 Tons*	Fans		Weights†			Refrigerant Operating Charge lbs.***	Coil Volume ft ³	Spray Pump		Remote Pump			Dimensions				
		HP	CFM	Shipping	Heaviest Section†	Operating			HP	GPM	Gallons Req'd**	Conn. Size	Operating Weight	Height H	Upper U	Lower E	Coil A	Length L
eco-ATC-226-1g	161	7.5	39,500	9,460	8,020	12,390	161	22	2	410	250	8"	11,110	11' 3-3/8"	6' 11-1/2"	4' 3 7/8"	19-1/2"	8' 11-1/2"
eco-ATC-242-1g	172	10	43,500	9,470	8,030	12,400	161	22	2	410	250	8"	11,120	11' 3-3/8"	6' 11-1/2"	4' 3 7/8"	19-1/2"	8' 11-1/2"
eco-ATC-248-1g	176	7.5	38,400	11,070	9,630	14,090	210	29	2	410	250	8"	12,810	11' 10-7/8"	7' 7"	4' 3 7/8"	27"	8' 11-1/2"
eco-ATC-262-1g	186	15	48,900	9,600	8,160	12,530	161	22	2	410	250	8"	11,250	11' 3-3/8"	6' 11-1/2"	4' 3 7/8"	19-1/2"	8' 11-1/2"
eco-ATC-263-1g	187	7.5	37,200	12,790	11,350	15,900	260	35	2	410	250	8"	14,620	12' 6-3/8"	8' 2-1/2"	4' 3 7/8"	34-1/2"	8' 11-1/2"
eco-ATC-266-1g	189	10	42,200	11,080	9,640	14,100	210	29	2	410	250	8"	12,820	11' 10-7/8"	7' 7"	4' 3 7/8"	27"	8' 11-1/2"
eco-ATC-279-1g	198	10	40,900	12,800	11,360	15,910	260	35	2	410	250	8"	14,630	12' 6-3/8"	8' 2-1/2"	4' 3 7/8"	34-1/2"	8' 11-1/2"
eco-ATC-288-1g	205	15	47,500	11,210	9,770	14,230	210	29	2	410	250	8"	12,950	11' 10-7/8"	7' 7"	4' 3 7/8"	27"	8' 11-1/2"
eco-ATC-303-1g	215	15	46,100	12,930	11,490	16,040	260	35	2	410	250	8"	14,760	12' 6-3/8"	8' 2-1/2"	4' 3 7/8"	34-1/2"	8' 11-1/2"
eco-ATC-316-1g	225	15	44,600	14,610	13,170	17,820	309	42	2	410	250	8"	16,540	13' 1-7/8"	8' 10"	4' 3 7/8"	42"	8' 11-1/2"
eco-ATC-334-1g	237	20	48,400	14,670	13,230	17,880	309	42	2	410	250	8"	16,600	13' 1-7/8"	8' 10"	4' 3 7/8"	42"	8' 11-1/2"

* Tons at standard conditions: 96.3°F condensing, 20°F suction and 78°F W.B.

** Gallons shown is water in suspension in unit and piping. Allow for additional water in bottom of remote sump to cover pump suction and strainer during operation. (12" would normally be sufficient.)

† Heaviest section is the coil section. **Weights shown are for 1g seismic design.**

*** Refrigerant charge is shown for R-717. Multiply by 1.93 for R-22 and 1.98 for R-134a.

Dimensions are subject to change. Do not use for pre-fabrication. Quantity of coil connections subject to change based on refrigerant and design conditions.



Engineering Dimensions & Data

Models eco-ATC-255-1g to 401-1g

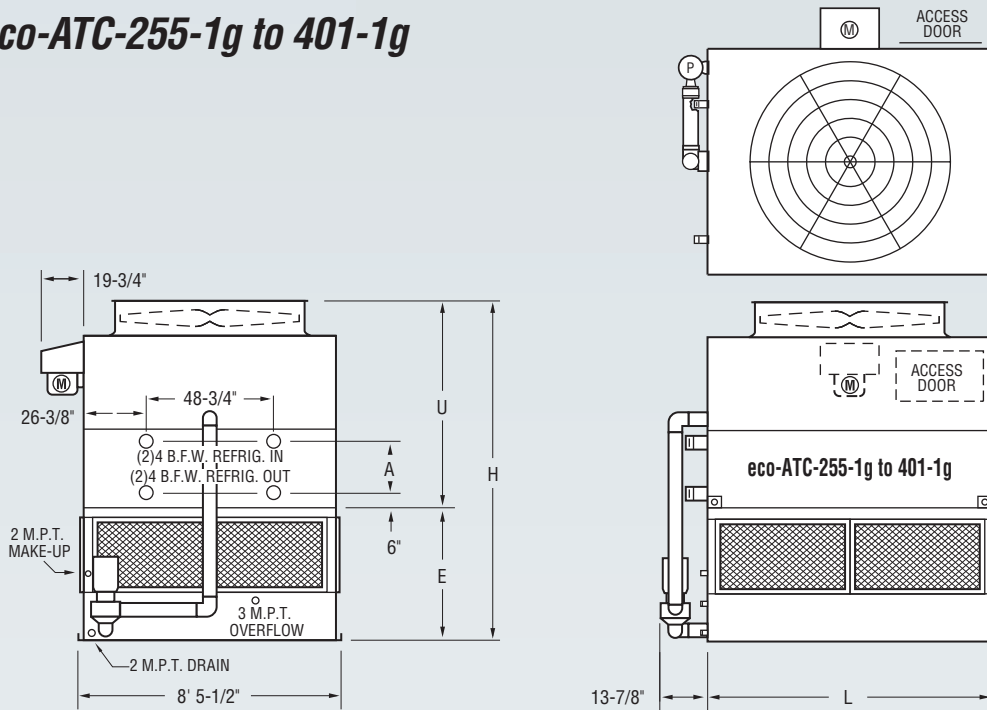

Table 3 Engineering Data

Model No.	R-717 Tons*	Fans		Weights†			Refrigerant Operating Charge lbs.***	Coil Volume ft ³	Spray Pump		Remote Pump			Dimensions				
		HP	CFM	Shipping	Heaviest Section†	Operating			HP	GPM	Gallons Req'd**	Conn. Size	Operating Weight	Height H	Upper U	Lower E	Coil A	Length L
eco-ATC-255-1g	181	15	56,300	9,260	7,620	12,600	129	18	3	500	290	10"	11,090	10' 7-7/8"	6' 4"	4' 3-7/8"	12"	10' 5-1/2"
eco-ATC-275-1g	196	10	48,200	10,930	9,290	14,380	187	25	3	500	290	10"	12,870	11' 3-3/8"	6' 11-1/2"	4' 3-7/8"	19 1/2"	10' 5-1/2"
eco-ATC-285-1g	203	7.5	42,500	12,780	11,140	16,340	244	33	3	500	290	10"	14,830	11' 10-7/8"	7' 7"	4' 3-7/8"	27"	10' 5-1/2"
eco-ATC-300-1g	213	15	54,700	11,050	9,410	14,500	187	25	3	500	290	10"	12,990	11' 3-3/8"	6' 11-1/2"	4' 3-7/8"	19 1/2"	10' 5-1/2"
eco-ATC-302-1g	215	10	46,800	12,800	11,160	16,360	244	33	3	500	290	10"	14,850	11' 10-7/8"	7' 7"	4' 3-7/8"	27"	10' 5-1/2"
eco-ATC-317-1g	225	10	45,400	14,820	13,180	18,490	302	41	3	500	290	10"	16,980	12' 6-3/8"	8' 2-1/2"	4' 3-7/8"	34 1/2"	10' 5-1/2"
eco-ATC-330-1g	235	15	53,100	12,920	11,280	16,480	244	33	3	500	290	10"	14,970	11' 10-7/8"	7' 7"	4' 3-7/8"	27"	10' 5-1/2"
eco-ATC-347-1g	247	15	51,500	14,940	13,300	18,610	302	41	3	500	290	10"	17,100	12' 6-3/8"	8' 2-1/2"	4' 3-7/8"	34 1/2"	10' 5-1/2"
eco-ATC-363-1g	258	15	49,900	16,890	15,250	20,670	359	49	3	500	290	10"	19,160	13' 1-7/8"	8' 10"	4' 3-7/8"	42"	10' 5-1/2"
eco-ATC-367-1g	261	20	55,900	15,000	13,360	18,670	302	41	3	500	290	10"	17,160	12' 6-3/8"	8' 2-1/2"	4' 3-7/8"	34 1/2"	10' 5-1/2"
eco-ATC-384-1g	273	20	54,100	16,950	15,310	20,730	359	49	3	500	290	10"	19,220	13' 1-7/8"	8' 10"	4' 3-7/8"	42"	10' 5-1/2"
eco-ATC-401-1g	285	25	57,600	16,980	15,340	20,760	359	49	3	500	290	10"	19,250	13' 1-7/8"	8' 10"	4' 3-7/8"	42"	10' 5-1/2"

* Tons at standard conditions: 96.3°F condensing, 20°F suction and 78°F W.B.

** Gallons shown is water in suspension in unit and piping. Allow for additional water in bottom of remote sump to cover pump suction and strainer during operation. (12" would normally be sufficient.)

† Heaviest section is the coil section. **Weights shown are for 1g seismic design.**

*** Refrigerant charge is shown for R-717. Multiply by 1.93 for R-22 and 1.98 for R-134a.

Dimensions are subject to change. Do not use for pre-fabrication. Quantity of coil connections subject to change based on refrigerant and design conditions.

Engineering Dimensions & Data

Models *eco-ATC-360-1g* to *487-1g*

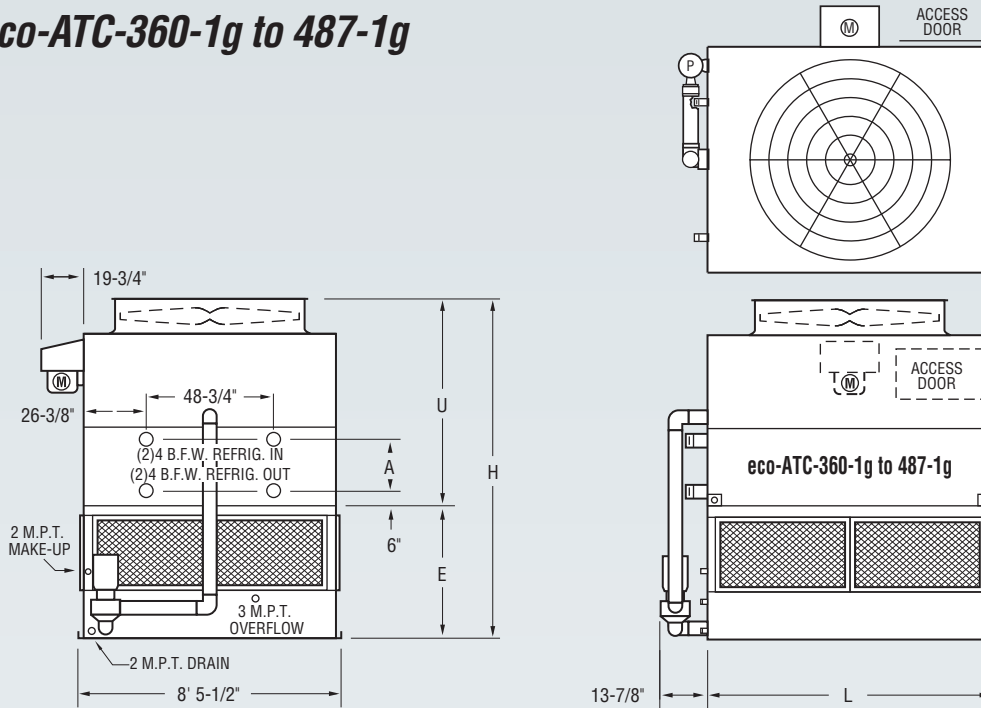

Table 4 Engineering Data

Model No.	R-717 Tons*	Fans		Weights†			Refrigerant Operating Charge lbs.***	Coil Volume ft ³	Spray Pump		Remote Pump			Dimensions				
		HP	CFM	Shipping	Heaviest Section†	Operating			HP	GPM	Gallons Req'd**	Conn. Size	Operating Weight	Height H	Upper U	Lower E	Coil A	Length L
eco-ATC-360-1g	256	10	48,200	18,490	16,620	22,910	410	56	5	550	330	10"	21,130	13' 6-1/4"	8' 10"	4' 8-1/4"	42"	11' 11-3/4"
eco-ATC-362-1g	257	15	58,500	14,210	12,340	18,380	278	38	5	550	330	10"	16,600	12' 3-1/4"	7' 7"	4' 8-1/4"	27"	11' 11-3/4"
eco-ATC-380-1g	270	15	56,800	16,380	14,510	20,680	344	47	5	550	330	10"	18,900	12' 103/4"	8' 2-1/2"	4' 8-1/4"	34 1/2"	11' 11-3/4"
eco-ATC-383-1g	272	20	63,500	14,270	12,400	18,440	278	38	5	550	330	10"	16,660	12' 3-1/4"	7' 7"	4' 8-1/4"	27"	11' 11-3/4"
eco-ATC-396-1g	281	15	55,000	18,620	16,750	23,040	410	56	5	550	330	10"	21,260	13' 6-1/4"	8' 10"	4' 8-1/4"	42"	11' 11-3/4"
eco-ATC-402-1g	286	20	61,500	16,440	14,570	20,740	344	47	5	550	330	10"	18,960	12' 10-3/4"	8' 2-1/2"	4' 8-1/4"	34 1/2"	11' 11-3/4"
eco-ATC-421-1g	299	25	65,500	16,470	14,600	20,770	344	47	5	550	330	10"	18,990	12' 10-3/4"	8' 2-1/2"	4' 8-1/4"	34 1/2"	11' 11-3/4"
eco-ATC-422-1g	300	20	59,700	18,680	16,810	23,100	410	56	5	550	330	10"	21,320	13' 6-1/4"	8' 10"	4' 8-1/4"	42"	11' 11-3/4"
eco-ATC-439-1g	312	25	63,500	18,710	16,840	23,130	410	56	5	550	330	10"	21,350	13' 6-1/4"	8' 10"	4' 8-1/4"	42"	11' 11-3/4"
eco-ATC-385-1g	274	20	73,000	13,690	11,610	18,390	246	33	5	600	380	10"	16,360	11' 7-3/4"	6' 11-1/2"	4' 8-1/4"	19-1/2"	13' 11-3/4"
eco-ATC-386-1g	274	10	55,100	18,570	16,490	23,560	400	54	5	600	380	10"	21,530	12' 10-3/4"	8' 2-1/2"	4' 8-1/4"	34-1/2"	13' 11-3/4"
eco-ATC-399-1g	283	15	65,000	16,160	14,080	21,000	323	44	5	600	380	10"	18,970	12' 3-1/4"	7' 7"	4' 8-1/4"	27"	13' 11-3/4"
eco-ATC-420-1g	298	15	63,000	18,700	16,620	23,690	400	54	5	600	380	10"	21,660	12' 10-3/4"	8' 2-1/2"	4' 8-1/4"	34-1/2"	13' 11-3/4"
eco-ATC-444-1g	315	25	75,500	16,250	14,170	21,090	323	44	5	600	380	10"	19,060	12' 3-1/4"	7' 7"	4' 8-1/4"	27"	13' 11-3/4"
eco-ATC-446-1g	317	20	68,800	18,760	16,680	23,750	400	54	5	600	380	10"	21,720	12' 10-3/4"	8' 2-1/2"	4' 8-1/4"	34-1/2"	13' 11-3/4"
eco-ATC-466-1g	331	25	73,300	18,790	16,710	23,780	400	54	5	600	380	10"	21,750	12' 10-3/4"	8' 2-1/2"	4' 8-1/4"	34-1/2"	13' 11-3/4"
eco-ATC-467-1g	332	20	66,600	21,360	19,280	26,500	477	65	5	600	380	10"	24,470	13' 6-1/4"	8' 10"	4' 8-1/4"	42"	13' 11-3/4"
eco-ATC-487-1g	346	25	71,000	21,390	19,310	26,530	477	65	5	600	380	10"	24,500	13' 6-1/4"	8' 10"	4' 8-1/4"	42"	13' 11-3/4"

* Tons at standard conditions: 96.3°F condensing, 20°F suction and 78°F W.B.
 ** Gallons shown is water in suspension in unit and piping. Allow for additional water in bottom of remote sump to cover pump suction and strainer during operation. (12" would normally be sufficient.)
 † Heaviest section is the coil section. **Weights shown are for 1g seismic design.**
 *** Refrigerant charge is shown for R-717. Multiply by 1.93 for R-22 and 1.98 for R-134a.
 Dimensions are subject to change. Do not use for pre-fabrication. Quantity of coil connections subject to change based on refrigerant and design conditions.



Engineering Dimensions & Data

Models eco-ATC-477-1g to 797-1g

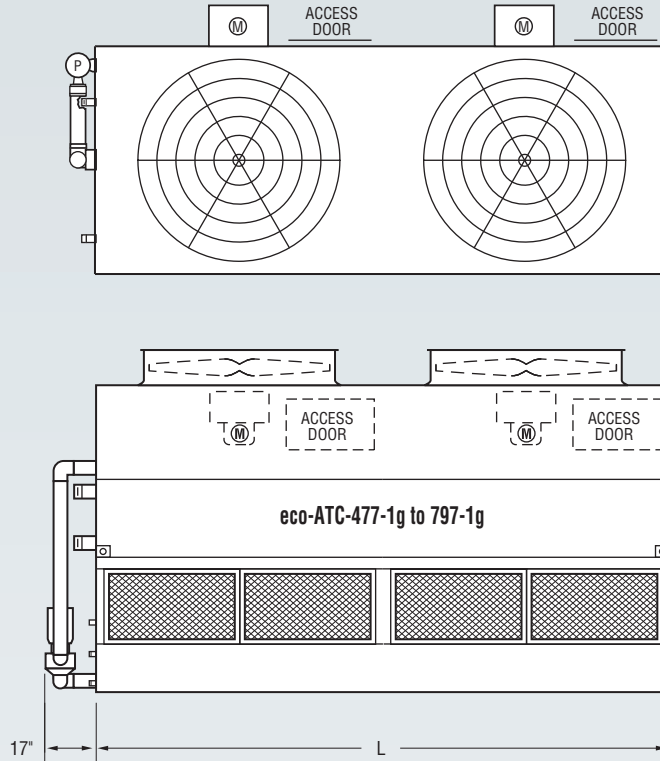
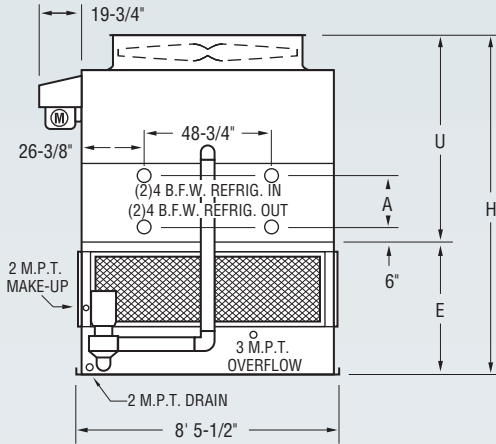

Table 5 Engineering Data

Model No.	R-717 Tons*	Fans		Weights†			Refrigerant Operating Charge lbs.***	Coil Volume ft ³	Spray Pump		Remote Pump			Dimensions				
		HP	CFM	Shipping	Heaviest Section†	Operating			HP	GPM	Gallons Req'd**	Conn. Size	Operating Weight	Height H	Upper U	Lower E	Coil A	Length L
eco-ATC-477-1g	339	(2) 10	87,200	18,030	15,240	24,140	313	43	5	800	510	12"	21,590	11' 11-3/4"	6' 11-1/2"	5' 1/4"	19-1/2"	18' 0"
eco-ATC-491-1g	349	(2) 7.5	77,000	21,300	18,510	27,600	412	56	5	800	510	12"	25,050	12' 7-1/4"	7' 7"	5' 1/4"	27"	18' 0"
eco-ATC-520-1g	369	(2) 15	98,200	18,280	15,490	24,390	313	43	5	800	510	12"	21,840	11' 11-3/4"	6' 11-1/2"	5' 1/4"	19-1/2"	18' 0"
eco-ATC-527-1g	374	(2) 10	84,800	21,330	18,540	27,630	412	56	5	800	510	12"	25,080	12' 7-1/4"	7' 7"	5' 1/4"	27"	18' 0"
eco-ATC-556-1g	395	(2) 10	82,100	24,550	21,760	31,040	512	70	5	800	510	12"	28,490	13' 2-3/4"	8' 2-1/2"	5' 1/4"	34-1/2"	18' 0"
eco-ATC-574-1g	408	(2) 15	95,300	21,580	18,790	27,880	412	56	5	800	510	12"	25,330	12' 7-1/4"	7' 7"	5' 1/4"	27"	18' 0"
eco-ATC-578-1g	410	(2) 10	79,600	27,920	25,130	34,600	612	83	5	800	510	12"	32,050	13' 10-1/4"	8' 10"	5' 1/4"	42"	18' 0"
eco-ATC-603-1g	428	(2) 15	92,500	24,800	22,010	31,290	512	70	5	800	510	12"	28,740	13' 2-3/4"	8' 2-1/2"	5' 1/4"	34-1/2"	18' 0"
eco-ATC-630-1g	447	(2) 15	89,500	28,170	25,380	34,850	612	83	5	800	510	12"	32,300	13' 10-1/4"	8' 10"	5' 1/4"	42"	18' 0"
eco-ATC-668-1g	474	(2) 20	97,100	28,290	25,500	34,970	612	83	5	800	510	12"	32,420	13' 10-1/4"	8' 10"	5' 1/4"	42"	18' 0"
eco-ATC-501-1g	356	(2) 15	107,000	17,240	14,140	24,240	247	34	7-1/2	1050	590	12"	21,270	11' 4-1/4"	6' 4"	5' 1/4"	12"	21' 0"
eco-ATC-540-1g	383	(2) 10	96,700	20,550	17,450	27,770	363	50	7-1/2	1050	590	12"	24,800	11' 11-3/4"	6' 11-1/2"	5' 1/4"	19-1/2"	21' 0"
eco-ATC-561-1g	398	(2) 7.5	85,300	24,370	21,270	31,820	480	65	7-1/2	1050	590	12"	28,850	12' 7-1/4"	7' 7"	5' 1/4"	27"	21' 0"
eco-ATC-592-1g	420	(2) 15	104,100	20,800	17,700	28,020	363	50	7-1/2	1050	590	12"	25,050	11' 11-3/4"	6' 11-1/2"	5' 1/4"	19-1/2"	21' 0"
eco-ATC-597-1g	424	(2) 10	93,800	24,400	21,300	31,850	480	65	7-1/2	1050	590	12"	28,880	12' 7-1/4"	7' 7"	5' 1/4"	27"	21' 0"
eco-ATC-628-1g	446	(2) 10	91,100	28,150	25,050	35,820	596	81	7-1/2	1050	590	12"	32,850	13' 2-3/4"	8' 2-1/2"	5' 1/4"	34-1/2"	21' 0"
eco-ATC-654-1g	464	(2) 15	101,200	24,650	21,550	32,100	480	65	7-1/2	1050	590	12"	29,130	12' 7-1/4"	7' 7"	5' 1/4"	27"	21' 0"
eco-ATC-656-1g	466	(2) 10	88,200	32,060	28,960	39,950	713	97	7-1/2	1050	590	12"	36,980	13' 10-1/4"	8' 10"	5' 1/4"	42"	21' 0"
eco-ATC-688-1g	488	(2) 15	98,200	28,400	25,300	36,070	596	81	7-1/2	1050	590	12"	33,100	13' 2-3/4"	8' 2-1/2"	5' 1/4"	34-1/2"	21' 0"
eco-ATC-718-1g	510	(2) 15	95,100	32,310	29,210	40,200	713	97	7-1/2	1050	590	12"	37,230	13' 10-1/4"	8' 10"	5' 1/4"	42"	21' 0"
eco-ATC-730-1g	518	(2) 20	103,400	28,520	25,420	36,190	596	81	7-1/2	1050	590	12"	33,220	13' 2-3/4"	8' 2-1/2"	5' 1/4"	34-1/2"	21' 0"
eco-ATC-762-1g	541	(2) 20	100,100	32,430	29,330	40,320	713	97	7-1/2	1050	590	12"	37,350	13' 10-1/4"	8' 10"	5' 1/4"	42"	21' 0"
eco-ATC-797-1g	566	(2) 25	108,600	32,490	29,390	40,380	713	97	7-1/2	1050	590	12"	37,410	13' 10-1/4"	8' 10"	5' 1/4"	42"	21' 0"

* Tons at standard conditions: 96.3°F condensing, 20°F suction and 78°F W.B.

** Gallons shown is water in suspension in unit and piping. Allow for additional water in bottom of remote sump to cover pump suction and strainer during operation. (12" would normally be sufficient.)

† Heaviest section is the coil section. **Weights shown are for 1g seismic design.**

*** Refrigerant charge is shown for R-717. Multiply by 1.93 for R-22 and 1.98 for R-134a.

Dimensions are subject to change. Do not use for pre-fabrication. Quantity of coil connections subject to change based on refrigerant and design conditions.

Engineering Dimensions & Data

Models eco-ATC-657-1g to 1010-1g

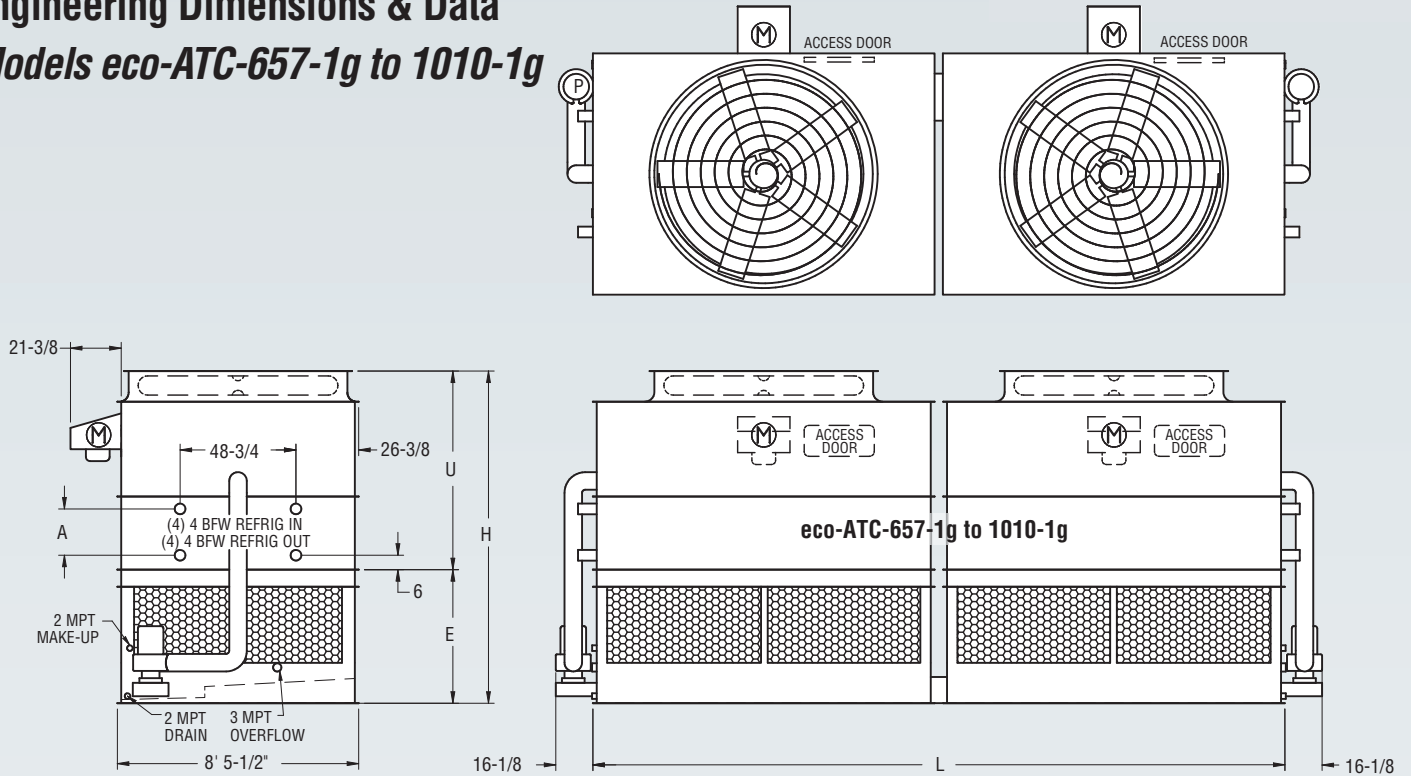

Table 6 Engineering Data

Model No.	R-717 Tons*	Fans		Weights†			Refrigerant Operating Charge lbs.***	Coil Volume ft ³	Spray Pump		Remote Pump			Dimensions				
		HP	CFM	Shipping	Heaviest Section†	Operating			HP	GPM	Gallons Req'd**	Conn. Size	Operating Weight	Height H	Upper U	Lower E	Coil A	Length L
eco-ATC-657-1g	466	(2) 15	120,000	24,040	10,150	32,120	424	58	(2) 5	1100	660	(2) 10"	28,560	11' 11-3/4"	6' 11-1/2"	5' 1/4"	19-1/2"	24' 2"
eco-ATC-659-1g	468	(2) 10	102,000	28,160	12,210	36,500	556	76	(2) 5	1100	660	(2) 10"	32,940	12' 7-1/4"	7' 7"	5' 1/4"	27"	24' 2"
eco-ATC-691-1g	491	(2) 10	98,900	32,500	14,380	41,100	688	94	(2) 5	1100	660	(2) 10"	37,540	13' 2-3/4"	8' 2-1/2"	5' 1/4"	34-1/2"	24' 2"
eco-ATC-694-1g	493	(2) 20	130,000	24,160	10,210	32,240	424	58	(2) 5	1100	660	(2) 10"	28,680	11' 11-3/4"	6' 11-1/2"	5' 1/4"	19-1/2"	24' 2"
eco-ATC-723-1g	513	(2) 15	116,500	28,420	12,340	36,760	556	76	(2) 5	1100	660	(2) 10"	33,200	12' 7-1/4"	7' 7"	5' 1/4"	27"	24' 2"
eco-ATC-759-1g	539	(2) 15	113,000	32,760	14,510	41,360	688	94	(2) 5	1100	660	(2) 10"	37,800	13' 2-3/4"	8' 2-1/2"	5' 1/4"	34-1/2"	24' 2"
eco-ATC-765-1g	543	(2) 20	126,300	28,540	12,400	36,880	556	76	(2) 5	1100	660	(2) 10"	33,320	12' 7-1/4"	7' 7"	5' 1/4"	27"	24' 2"
eco-ATC-803-1g	570	(2) 20	122,400	32,880	14,570	41,480	688	94	(2) 5	1100	660	(2) 10"	37,920	13' 2-3/4"	8' 2-1/2"	5' 1/4"	34-1/2"	24' 2"
eco-ATC-839-1g	596	(2) 20	118,800	37,360	16,810	46,200	819	112	(2) 5	1100	660	(2) 10"	42,640	13' 10-1/4"	8' 10"	5' 1/4"	42"	24' 2"
eco-ATC-841-1g	597	(2) 25	130,400	32,940	14,600	41,540	688	94	(2) 5	1100	660	(2) 10"	37,980	13' 2-3/4"	8' 2-1/2"	5' 1/4"	34-1/2"	24' 2"
eco-ATC-876-1g	622	(2) 25	126,300	37,420	16,840	46,260	819	112	(2) 5	1100	660	(2) 10"	42,700	13' 10-1/4"	8' 10"	5' 1/4"	42"	24' 2"
eco-ATC-770-1g	547	(2) 10	111,300	37,140	16,490	47,120	800	109	(2) 5	1200	760	(2) 10"	43,060	13' 8-3/4"	8' 2-1/2"	5' 6 1/4"	34-1/2"	28' 2"
eco-ATC-798-1g	566	(2) 15	131,200	32,320	14,080	42,000	645	88	(2) 5	1200	760	(2) 10"	37,940	13' 1-1/4"	7' 7"	5' 6 1/4"	27"	28' 2"
eco-ATC-805-1g	571	(2) 10	107,900	42,340	19,090	52,620	954	130	(2) 5	1200	760	(2) 10"	48,560	14' 4-1/4"	8' 10"	5' 6 1/4"	42"	28' 2"
eco-ATC-837-1g	594	(2) 15	127,400	37,400	16,620	47,380	800	109	(2) 5	1200	760	(2) 10"	43,320	13' 8-3/4"	8' 2-1/2"	5' 6 1/4"	34-1/2"	28' 2"
eco-ATC-848-1g	602	(2) 20	143,400	32,440	14,140	42,120	645	88	(2) 5	1200	760	(2) 10"	38,060	13' 1-1/4"	7' 7"	5' 6 1/4"	27"	28' 2"
eco-ATC-875-1g	621	(2) 15	123,500	42,600	19,220	52,880	954	130	(2) 5	1200	760	(2) 10"	48,820	14' 4-1/4"	8' 10"	5' 6 1/4"	42"	28' 2"
eco-ATC-887-1g	630	(2) 25	152,600	32,500	14,170	42,180	645	88	(2) 5	1200	760	(2) 10"	38,120	13' 1-1/4"	7' 7"	5' 6 1/4"	27"	28' 2"
eco-ATC-891-1g	632	(2) 20	139,000	37,520	16,680	47,500	800	109	(2) 5	1200	760	(2) 10"	43,440	13' 8-3/4"	8' 2-1/2"	5' 6 1/4"	34-1/2"	28' 2"
eco-ATC-931-1g	661	(2) 20	134,600	42,720	19,280	53,000	954	130	(2) 5	1200	760	(2) 10"	48,940	14' 4-1/4"	8' 10"	5' 6 1/4"	42"	28' 2"
eco-ATC-933-1g	662	(2) 25	148,000	37,580	16,710	47,560	800	109	(2) 5	1200	760	(2) 10"	43,500	13' 8-3/4"	8' 2-1/2"	5' 6 1/4"	34-1/2"	28' 2"
eco-ATC-974-1g	691	(2) 25	143,400	42,780	19,310	53,060	954	130	(2) 5	1200	760	(2) 10"	49,000	14' 4-1/4"	8' 10"	5' 6 1/4"	42"	28' 2"
eco-ATC-1010-1g	717	(2) 30	150,900	42,880	19,360	53,160	954	130	(2) 5	1200	760	(2) 10"	49,100	14' 4-1/4"	8' 10"	5' 6 1/4"	42"	28' 2"

* Tons at standard conditions: 96.3°F condensing, 20°F suction and 78°F W.B.

** Gallons shown is water in suspension in unit and piping. Allow for additional water in bottom of remote sump to cover pump suction and strainer during operation. (12" would normally be sufficient.)

† Heaviest section is the coil section. **Weights shown are for 1g seismic design.**

*** Refrigerant charge is shown for R-717. Multiply by 1.93 for R-22 and 1.98 for R-134a.

Dimensions are subject to change. Do not use for pre-fabrication. Quantity of coil connections subject to change based on refrigerant and design conditions.



Engineering Dimensions & Data

Models eco-ATC-658-1g to 1011-1g

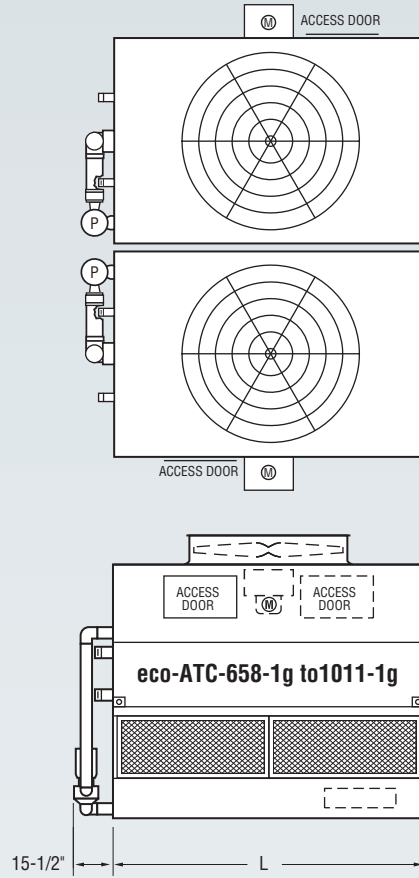
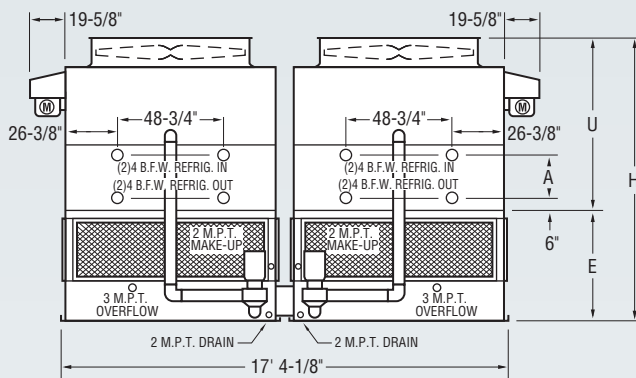

Table 7 Engineering Data

Model No.	R-717 Tons*	Fans		Weights†			Refrigerant Operating Charge lbs.***	Coil Volume ft ³	Spray Pump		Remote Pump			Dimensions				
		HP	CFM	Shipping	Heaviest Section†	Operating			HP	GPM	Gallons Req'd**	Conn. Size	Operating Weight	Height H	Upper U	Lower E	Coil A	Length L
eco-ATC-658-1g	467	(2) 15	119,400	24,040	10,150	32,120	424	58	(2) 5	1100	660	(2) 10"	28,560	11' 11-3/4"	6' 11-1/2"	5' 1/4"	19-1/2"	11' 11-3/4"
eco-ATC-660-1g	469	(2) 10	101,500	28,160	12,210	36,500	556	76	(2) 5	1100	660	(2) 10"	32,940	12' 7-1/4"	7' 7"	5' 1/4"	27"	11' 11-3/4"
eco-ATC-692-1g	491	(2) 10	98,400	32,500	14,380	41,100	688	94	(2) 5	1100	660	(2) 10"	37,540	13' 2-3/4"	8' 2-1/2"	5' 1/4"	34-1/2"	11' 11-3/4"
eco-ATC-695-1g	493	(2) 20	129,400	24,160	10,210	32,240	424	58	(2) 5	1100	660	(2) 10"	28,680	11' 11-3/4"	6' 11-1/2"	5' 1/4"	19-1/2"	11' 11-3/4"
eco-ATC-724-1g	514	(2) 15	115,900	28,420	12,340	36,760	556	76	(2) 5	1100	660	(2) 10"	33,200	12' 7-1/4"	7' 7"	5' 1/4"	27"	11' 11-3/4"
eco-ATC-760-1g	540	(2) 15	112,500	32,760	14,510	41,360	688	94	(2) 5	1100	660	(2) 10"	37,800	13' 2-3/4"	8' 2-1/2"	5' 1/4"	34-1/2"	11' 11-3/4"
eco-ATC-766-1g	544	(2) 20	125,700	28,540	12,400	36,880	556	76	(2) 5	1100	660	(2) 10"	33,320	12' 7-1/4"	7' 7"	5' 1/4"	27"	11' 11-3/4"
eco-ATC-804-1g	571	(2) 20	121,800	32,880	14,570	41,480	688	94	(2) 5	1100	660	(2) 10"	37,920	13' 2-3/4"	8' 2-1/2"	5' 1/4"	34-1/2"	11' 11-3/4"
eco-ATC-840-1g	596	(2) 20	118,200	37,360	16,810	46,200	819	112	(2) 5	1100	660	(2) 10"	42,640	13' 10-1/4"	8' 10"	5' 1/4"	42"	11' 11-3/4"
eco-ATC-842-1g	598	(2) 25	129,800	32,940	14,600	41,540	688	94	(2) 5	1100	660	(2) 10"	37,980	13' 2-3/4"	8' 2-1/2"	5' 1/4"	34-1/2"	11' 11-3/4"
eco-ATC-877-1g	622	(2) 25	125,700	37,420	16,840	46,260	819	112	(2) 5	1100	660	(2) 10"	42,700	13' 10-1/4"	8' 10"	5' 1/4"	42"	11' 11-3/4"
eco-ATC-771-1g	547	(2) 10	109,100	37,140	16,490	47,120	800	109	(2) 5	1200	760	(2) 10"	43,060	13' 8-3/4"	8' 2-1/2"	5' 6 1/4"	34-1/2"	13' 11-3/4"
eco-ATC-799-1g	567	(2) 15	128,600	32,320	14,080	42,000	645	88	(2) 5	1200	760	(2) 10"	37,940	13' 1-1/4"	7' 7"	5' 6 1/4"	27"	13' 11-3/4"
eco-ATC-838-1g	595	(2) 15	124,800	37,400	16,620	47,380	800	109	(2) 5	1200	760	(2) 10"	43,320	13' 8-3/4"	8' 2-1/2"	5' 6 1/4"	34-1/2"	13' 11-3/4"
eco-ATC-849-1g	603	(2) 20	140,500	32,440	14,140	42,120	645	88	(2) 5	1200	760	(2) 10"	38,060	13' 1-1/4"	7' 7"	5' 6 1/4"	27"	13' 11-3/4"
eco-ATC-888-1g	630	(2) 25	149,600	32,500	14,170	42,180	645	88	(2) 5	1200	760	(2) 10"	38,120	13' 1-1/4"	7' 7"	5' 6 1/4"	27"	13' 11-3/4"
eco-ATC-892-1g	633	(2) 20	136,200	37,520	16,680	47,500	800	109	(2) 5	1200	760	(2) 10"	43,440	13' 8-3/4"	8' 2-1/2"	5' 6 1/4"	34-1/2"	13' 11-3/4"
eco-ATC-932-1g	661	(2) 20	132,000	42,720	19,280	53,000	954	130	(2) 5	1200	760	(2) 10"	48,940	14' 4-1/4"	8' 10"	5' 6 1/4"	42"	13' 11-3/4"
eco-ATC-934-1g	663	(2) 25	145,000	37,580	16,710	47,560	800	109	(2) 5	1200	760	(2) 10"	43,500	13' 8-3/4"	8' 2-1/2"	5' 6 1/4"	34-1/2"	13' 11-3/4"
eco-ATC-975-1g	692	(2) 25	140,500	42,780	19,310	53,060	954	130	(2) 5	1200	760	(2) 10"	49,000	14' 4-1/4"	8' 10"	5' 6 1/4"	42"	13' 11-3/4"
eco-ATC-1011-1g	718	(2) 30	147,900	42,880	19,360	53,160	954	130	(2) 5	1200	760	(2) 10"	49,100	14' 4-1/4"	8' 10"	5' 6 1/4"	42"	13' 11-3/4"

* Tons at standard conditions: 96.3°F condensing, 20°F suction and 78°F W.B.

** Gallons shown is water in suspension in unit and piping. Allow for additional water in bottom of remote sump to cover pump suction and strainer during operation. (12" would normally be sufficient.)

† Heaviest section is the coil section. **Weights shown are for 1g seismic design.**

*** Refrigerant charge is shown for R-717. Multiply by 1.93 for R-22 and 1.98 for R-134a.

Dimensions are subject to change. Do not use for pre-fabrication. Quantity of coil connections subject to change based on refrigerant and design conditions.

Engineering Dimensions & Data

Models eco-ATC-280-1g to 503-1g

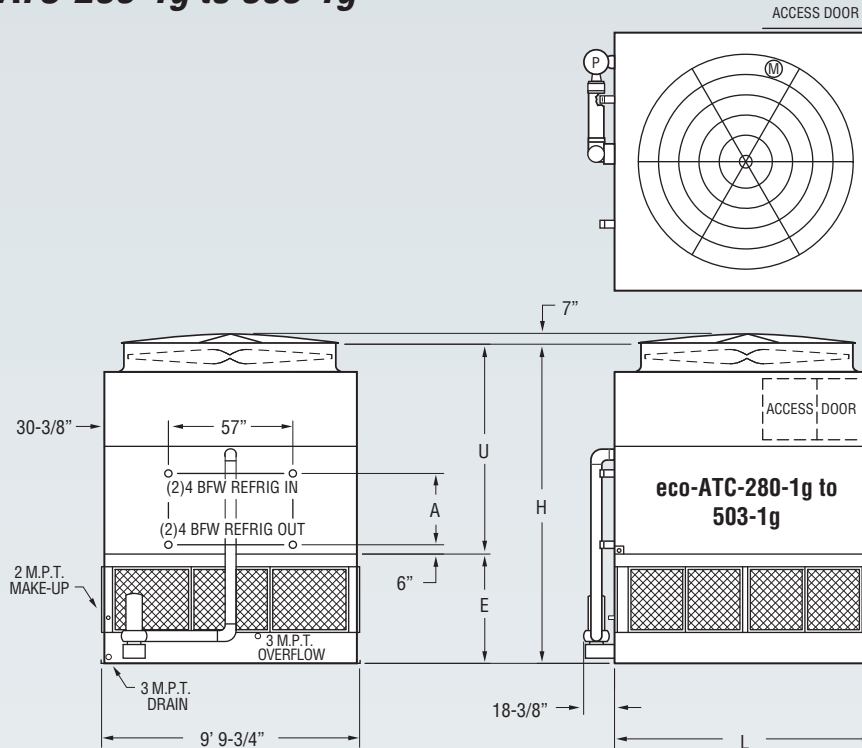

Table 8 Engineering Data

Model No.	R-717 Tons*	Fans		Weights†			Refrigerant Operating Charge lbs.***	Coil Volume ft ³	Spray Pump		Remote Pump			Dimensions				
		HP	CFM	Shipping	Heaviest Section†	Operating			HP	GPM	Gallons Req'd**	Conn. Size	Operating Weight	Height H	Upper U	Lower E	Coil A	Length L
eco-ATC-280-1g	199	10	59,200	12,210	9,660	17,930	171	23	5	685	420	12"	14,360	12' 9-3/8"	7' 7-1/8"	5' 2-1/4"	13 3/4"	11' 11-3/4"
eco-ATC-309-1g	220	7.5	53,000	14,580	12,030	20,450	249	34	5	685	420	12"	16,880	13' 5-7/8"	8' 3-5/8"	5' 2-1/4"	22 1/4"	11' 11-3/4"
eco-ATC-323-1g	230	20	74,500	12,400	9,850	18,120	171	23	5	685	420	12"	14,550	12' 9-3/8"	7' 7-1/8"	5' 2-1/4"	13 3/4"	11' 11-3/4"
eco-ATC-327-1g	232	10	58,300	14,590	12,040	20,460	249	34	5	685	420	12"	16,890	13' 5-7/8"	8' 3-5/8"	5' 2-1/4"	22 1/4"	11' 11-3/4"
eco-ATC-339-1g	241	25	80,300	12,430	9,880	18,150	171	23	5	685	420	12"	14,580	12' 9-3/8"	7' 7-1/8"	5' 2-1/4"	13 3/4"	11' 11-3/4"
eco-ATC-340-1g	242	7.5	52,200	17,170	14,620	23,190	326	44	5	685	420	12"	19,620	14' 2-3/8"	9' 1/8"	5' 2-1/4"	30 3/4"	11' 11-3/4"
eco-ATC-357-1g	254	15	66,700	14,720	12,170	20,590	249	34	5	685	420	12"	17,020	13' 5-7/8"	8' 3-5/8"	5' 2-1/4"	22 1/4"	11' 11-3/4"
eco-ATC-361-1g	257	10	57,400	17,180	14,630	23,200	326	44	5	685	420	12"	19,630	14' 2-3/8"	9' 1/8"	5' 2-1/4"	30 3/4"	11' 11-3/4"
eco-ATC-379-1g	269	10	56,600	19,660	17,110	25,830	404	55	5	685	420	12"	22,260	14' 10-7/8"	9' 8-5/8"	5' 2-1/4"	39 1/4"	11' 11-3/4"
eco-ATC-381-1g	271	20	73,500	14,780	12,230	20,650	249	34	5	685	420	12"	17,080	13' 5-7/8"	8' 3-5/8"	5' 2-1/4"	22 1/4"	11' 11-3/4"
eco-ATC-393-1g	279	15	65,700	17,310	14,760	23,330	326	44	5	685	420	12"	19,760	14' 2-3/8"	9' 1/8"	5' 2-1/4"	30 3/4"	11' 11-3/4"
eco-ATC-400-1g	284	25	79,100	14,810	12,260	20,680	249	34	5	685	420	12"	17,110	13' 5-7/8"	8' 3-5/8"	5' 2-1/4"	22 1/4"	11' 11-3/4"
eco-ATC-413-1g	293	15	64,800	19,790	17,240	25,960	404	55	5	685	420	12"	22,390	14' 10-7/8"	9' 8-5/8"	5' 2-1/4"	39 1/4"	11' 11-3/4"
eco-ATC-419-1g	298	20	72,400	17,370	14,820	23,390	326	44	5	685	420	12"	19,820	14' 2-3/8"	9' 1/8"	5' 2-1/4"	30 3/4"	11' 11-3/4"
eco-ATC-441-1g	313	25	78,000	17,400	14,850	23,420	326	44	5	685	420	12"	19,850	14' 2-3/8"	9' 1/8"	5' 2-1/4"	30 3/4"	11' 11-3/4"
eco-ATC-442-1g	314	20	71,300	19,850	17,300	26,020	404	55	5	685	420	12"	22,450	14' 10-7/8"	9' 8-5/8"	5' 2-1/4"	39 1/4"	11' 11-3/4"
eco-ATC-462-1g	328	25	76,800	19,880	17,330	26,050	404	55	5	685	420	12"	22,480	14' 10-7/8"	9' 8-5/8"	5' 2-1/4"	39 1/4"	11' 11-3/4"
eco-ATC-481-1g	342	30	81,600	19,930	17,380	26,100	404	55	5	685	420	12"	22,530	14' 10-7/8"	9' 8-5/8"	5' 2-1/4"	39 1/4"	11' 11-3/4"
eco-ATC-482-1g	342	25	75,700	22,510	19,960	28,830	481	66	5	685	420	12"	25,260	15' 7-3/8"	10' 5-1/8"	5' 2-1/4"	47 3/4"	11' 11-3/4"
eco-ATC-503-1g	357	30	80,400	22,560	20,010	28,880	481	66	5	685	420	12"	25,310	15' 7-3/8"	10' 5-1/8"	5' 2-1/4"	47 3/4"	11' 11-3/4"

* Tons at standard conditions: 96.3°F condensing, 20°F suction and 78°F W.B.

** Gallons shown is water in suspension in unit and piping. Allow for additional water in bottom of remote sump to cover pump suction and strainer during operation. (12" would normally be sufficient.)

† Heaviest section is the coil section. **Weights shown are for 1g seismic design.**

*** Refrigerant charge is shown for R-717. Multiply by 1.93 for R-22 and 1.98 for R-134a.

Dimensions are subject to change. Do not use for pre-fabrication. Quantity of coil connections subject to change based on refrigerant and design conditions.



Engineering Dimensions & Data

Models eco-ATC-365-1g to 705-1g

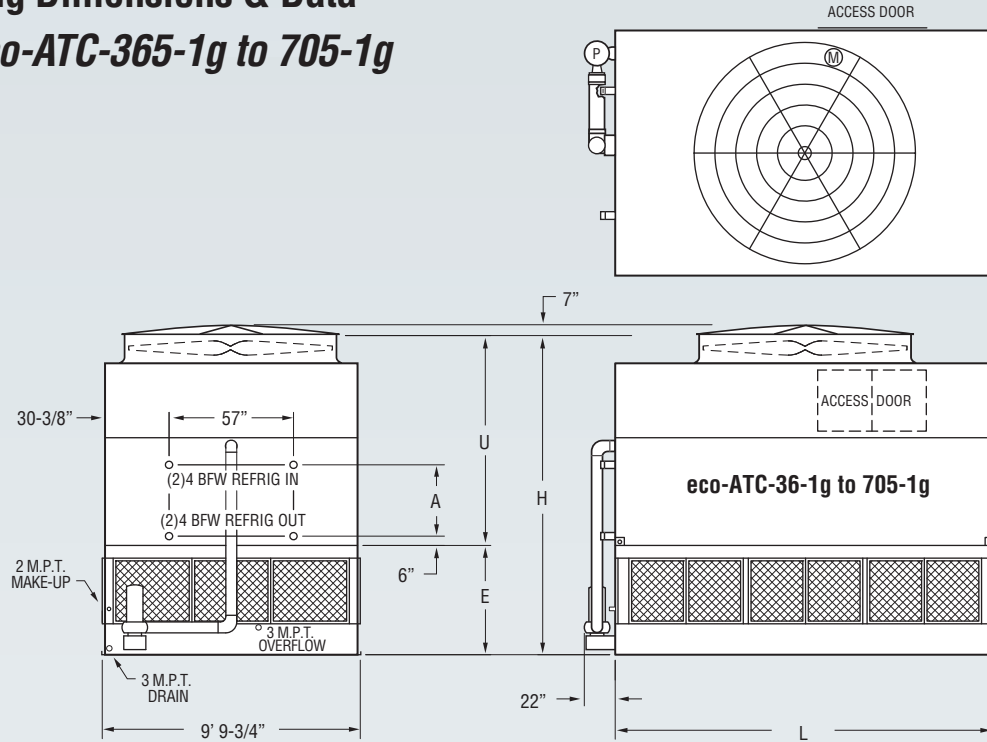

Table 9 Engineering Data

Model No.	R-717 Tons*	Fans		Weights†			Refrigerant Operating Charge lbs.***	Coil Volume ft ³	Spray Pump		Remote Pump			Dimensions				
		HP	CFM	Shipping	Heaviest Section†	Operating			HP	GPM	Gallons Req'd**	Conn. Size	Operating Weight	Height H	Upper U	Lower E	Coil A	Length L
eco-ATC-365-1g	259	10	79,200	17,300	13,650	25,940	250	34	7-1/2	1030	630	12"	20,690	12' 9-3/8"	7' 7-1/8"	5' 2-1/4"	13-3/4"	18' 0"
eco-ATC-405-1g	288	7.5	70,900	20,910	17,260	29,770	367	50	7-1/2	1030	630	12"	24,520	13' 5-7/8"	8' 3-5/8"	5' 2-1/4"	22-1/4"	18' 0"
eco-ATC-429-1g	305	10	78,100	20,920	17,270	29,780	367	50	7-1/2	1030	630	12"	24,530	13' 5-7/8"	8' 3-5/8"	5' 2-1/4"	22-1/4"	18' 0"
eco-ATC-448-1g	318	25	107,500	17,520	13,870	26,160	250	34	7-1/2	1030	630	12"	20,910	12' 9-3/8"	7' 7-1/8"	5' 2-1/4"	13-3/4"	18' 0"
eco-ATC-465-1g	330	30	114,300	17,570	13,920	26,210	250	34	7-1/2	1030	630	12"	20,960	12' 9-3/8"	7' 7-1/8"	5' 2-1/4"	13-3/4"	18' 0"
eco-ATC-469-1g	333	15	89,400	21,050	17,400	29,910	367	50	7-1/2	1030	630	12"	24,660	13' 5-7/8"	8' 3-5/8"	5' 2-1/4"	22-1/4"	18' 0"
eco-ATC-473-1g	336	10	76,900	24,790	21,140	33,880	484	66	7-1/2	1030	630	12"	28,630	14' 2-3/8"	9' 1/8"	5' 2-1/4"	30-3/4"	18' 0"
eco-ATC-502-1g	357	20	98,400	21,110	17,460	29,970	367	50	7-1/2	1030	630	12"	24,720	13' 5-7/8"	8' 3-5/8"	5' 2-1/4"	22-1/4"	18' 0"
eco-ATC-517-1g	367	15	88,100	24,920	21,270	34,010	484	66	7-1/2	1030	630	12"	28,760	14' 2-3/8"	9' 1/8"	5' 2-1/4"	30-3/4"	18' 0"
eco-ATC-528-1g	375	25	106,000	21,140	17,490	30,000	367	50	7-1/2	1030	630	12"	24,750	13' 5-7/8"	8' 3-5/8"	5' 2-1/4"	22-1/4"	18' 0"
eco-ATC-549-1g	390	30	112,600	21,190	17,540	30,050	367	50	7-1/2	1030	630	12"	24,800	13' 5-7/8"	8' 3-5/8"	5' 2-1/4"	22-1/4"	18' 0"
eco-ATC-555-1g	394	20	96,900	24,980	21,330	34,070	484	66	7-1/2	1030	630	12"	28,820	14' 2-3/8"	9' 1/8"	5' 2-1/4"	30-3/4"	18' 0"
eco-ATC-582-1g	413	25	104,400	25,010	21,360	34,100	484	66	7-1/2	1030	630	12"	28,850	14' 2-3/8"	9' 1/8"	5' 2-1/4"	30-3/4"	18' 0"
eco-ATC-584-1g	415	20	95,500	28,750	25,100	38,060	601	82	7-1/2	1030	630	12"	32,810	14' 10-7/8"	9' 8-5/8"	5' 2-1/4"	39-1/4"	18' 0"
eco-ATC-606-1g	430	30	110,900	25,060	21,410	34,150	484	66	7-1/2	1030	630	12"	28,900	14' 2-3/8"	9' 1/8"	5' 2-1/4"	30-3/4"	18' 0"
eco-ATC-612-1g	435	25	102,900	28,780	25,130	38,090	601	82	7-1/2	1030	630	12"	32,840	14' 10-7/8"	9' 8-5/8"	5' 2-1/4"	39-1/4"	18' 0"
eco-ATC-637-1g	452	30	109,300	28,830	25,180	38,140	601	82	7-1/2	1030	630	12"	32,890	14' 10-7/8"	9' 8-5/8"	5' 2-1/4"	39-1/4"	18' 0"
eco-ATC-638-1g	453	25	101,300	32,710	29,060	42,240	718	98	7-1/2	1030	630	12"	36,990	15' 7-3/8"	10' 5-1/8"	5' 2-1/4"	47-3/4"	18' 0"
eco-ATC-643-1g	457	40	122,100	25,220	21,570	34,310	484	66	7-1/2	1030	630	12"	29,060	14' 2-3/8"	9' 1/8"	5' 2-1/4"	30-3/4"	18' 0"
eco-ATC-665-1g	472	30	107,700	32,760	29,110	42,290	718	98	7-1/2	1030	630	12"	37,040	15' 7-3/8"	10' 5-1/8"	5' 2-1/4"	47-3/4"	18' 0"
eco-ATC-676-1g	480	40	120,300	28,990	25,340	38,300	601	82	7-1/2	1030	630	12"	33,050	14' 10-7/8"	9' 8-5/8"	5' 2-1/4"	39-1/4"	18' 0"
eco-ATC-705-1g	500	40	118,500	32,920	29,270	42,450	718	98	7-1/2	1030	630	12"	37,200	15' 7-3/8"	10' 5-1/8"	5' 2-1/4"	47-3/4"	18' 0"

* Tons at standard conditions: 96.3°F condensing, 20°F suction and 78°F W.B.

** Gallons shown is water in suspension in unit and piping. Allow for additional water in bottom of remote sump to cover pump suction and strainer during operation. (12" would normally be sufficient.)

† Heaviest section is the coil section. **Weights shown are for 1g seismic design.**

*** Refrigerant charge is shown for R-717. Multiply by 1.93 for R-22 and 1.98 for R-134a.

Dimensions are subject to change. Do not use for pre-fabrication. Quantity of coil connections subject to change based on refrigerant and design conditions.

Engineering Dimensions & Data

Models eco-ATC-559-1g to 1005-1g

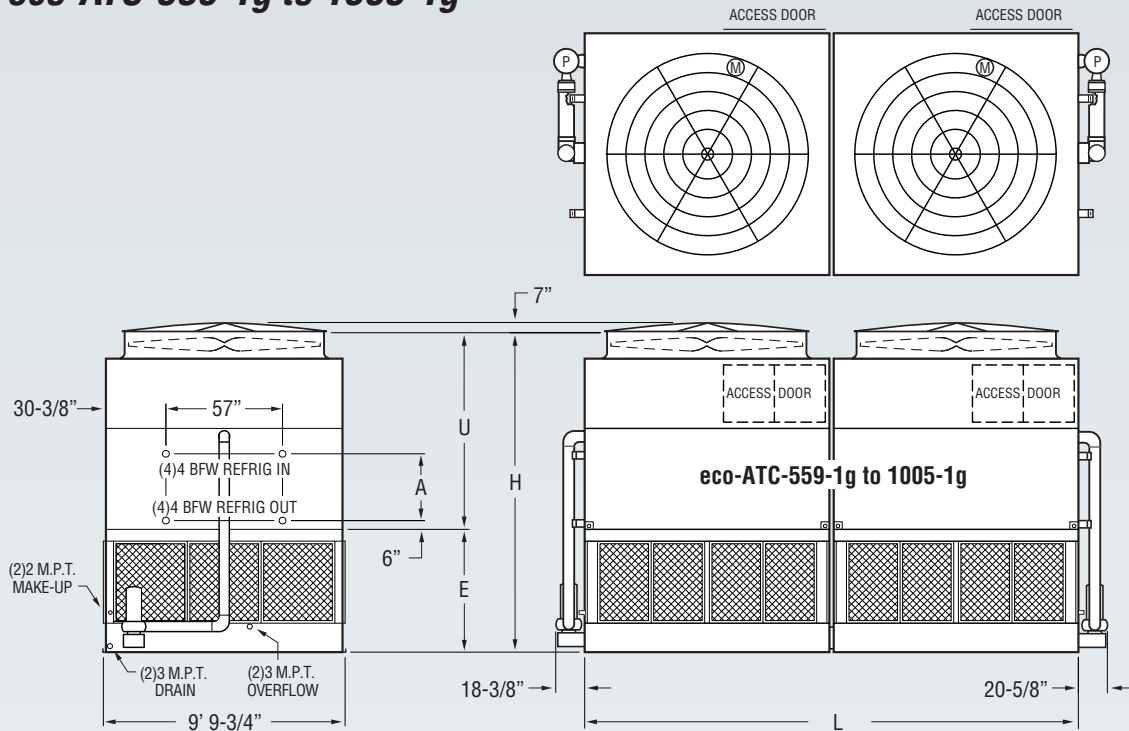

Table 10 Engineering Data

Model No.	R-717 Tons*	Fans		Weights†			Refrigerant Operating Charge lbs.***	Coil Volume ft ³	Spray Pump		Remote Pump			Dimensions				
		HP	CFM	Shipping	Heaviest Section†	Operating			HP	GPM	Gallons Req'd**	Conn. Size	Operating Weight	Height H	Upper U	Lower E	Coil A	Length L
eco-ATC-559-1g	397	(2) 10	118,300	24,680	9,660	36,120	342	47	(2) 5	1370	840	(2) 12"	28,980	13' 9-3/8"	7' 7-1/8"	6' 2-1/4"	13-3/4"	24' 2"
eco-ATC-619-1g	440	(2) 7.5	105,900	29,420	12,030	41,160	497	68	(2) 5	1370	840	(2) 12"	34,020	14' 5-7/8"	8' 3-5/8"	6' 2-1/4"	22-1/4"	24' 2"
eco-ATC-655-1g	465	(2) 10	116,600	29,440	12,040	41,180	497	68	(2) 5	1370	840	(2) 12"	34,040	14' 5-7/8"	8' 3-5/8"	6' 2-1/4"	22-1/4"	24' 2"
eco-ATC-678-1g	481	(2) 25	160,600	25,120	9,880	36,560	342	47	(2) 5	1370	840	(2) 12"	29,420	13' 9-3/8"	7' 7 1/8"	6' 2-1/4"	13-3/4"	24' 2"
eco-ATC-721-1g	512	(2) 10	114,900	34,620	14,630	46,660	652	89	(2) 5	1370	840	(2) 12"	39,520	15' 2-3/8"	9' 1/8"	6' 2-1/4"	30-3/4"	24' 2"
eco-ATC-761-1g	540	(2) 20	146,900	29,820	12,230	41,560	497	68	(2) 5	1370	840	(2) 12"	34,420	14' 5-7/8"	8' 3-5/8"	6' 2-1/4"	22-1/4"	24' 2"
eco-ATC-787-1g	559	(2) 15	131,500	34,880	14,760	46,920	652	89	(2) 5	1370	840	(2) 12"	39,780	15' 2-3/8"	9' 1/8"	6' 2-1/4"	30-3/4"	24' 2"
eco-ATC-800-1g	568	(2) 25	158,200	29,880	12,260	41,620	497	68	(2) 5	1370	840	(2) 12"	34,480	14' 5-7/8"	8' 3-5/8"	6' 2-1/4"	22-1/4"	24' 2"
eco-ATC-836-1g	593	(2) 20	144,700	35,000	14,820	47,040	652	89	(2) 5	1370	840	(2) 12"	39,900	15' 2-3/8"	9' 1/8"	6' 2-1/4"	30-3/4"	24' 2"
eco-ATC-879-1g	624	(2) 25	155,900	35,060	14,850	47,100	652	89	(2) 5	1370	840	(2) 12"	39,960	15' 2-3/8"	9' 1/8"	6' 2-1/4"	30-3/4"	24' 2"
eco-ATC-880-1g	625	(2) 20	142,600	39,960	17,300	52,300	807	110	(2) 5	1370	840	(2) 12"	45,160	15' 10-7/8"	9' 8-5/8"	6' 2-1/4"	39-1/4"	24' 2"
eco-ATC-918-1g	652	(2) 20	140,500	45,220	19,930	57,860	962	131	(2) 5	1370	840	(2) 12"	50,720	16' 7-3/8"	10' 5-1/8"	6' 2-1/4"	47-3/4"	24' 2"
eco-ATC-924-1g	656	(2) 25	153,600	40,020	17,330	52,360	807	110	(2) 5	1370	840	(2) 12"	45,220	15' 10-7/8"	9' 8-5/8"	6' 2-1/4"	39-1/4"	24' 2"
eco-ATC-962-1g	683	(2) 30	163,200	40,120	17,380	52,460	807	110	(2) 5	1370	840	(2) 12"	45,320	15' 10-7/8"	9' 8-5/8"	6' 2-1/4"	39-1/4"	24' 2"
eco-ATC-964-1g	684	(2) 25	151,300	45,280	19,960	57,920	962	131	(2) 5	1370	840	(2) 12"	50,780	16' 7-3/8"	10' 5-1/8"	6' 2-1/4"	47-3/4"	24' 2"
eco-ATC-1005-1g	713	(2) 30	160,800	45,380	20,010	58,020	962	131	(2) 5	1370	840	(2) 12"	50,880	16' 7-3/8"	10' 5-1/8"	6' 2-1/4"	47-3/4"	24' 2"

* Tons at standard conditions: 96.3°F condensing, 20°F suction and 78°F W.B.
 ** Gallons shown is water in suspension in unit and piping. Allow for additional water in bottom of remote sump to cover pump suction and strainer during operation. (12" would normally be sufficient.)
 † Heaviest section is the coil section. **Weights shown are for 1g seismic design.**
 *** Refrigerant charge is shown for R-717. Multiply by 1.93 for R-22 and 1.98 for R-134a.
 Dimensions are subject to change. Do not use for pre-fabrication. Quantity of coil connections subject to change based on refrigerant and design conditions.



Engineering Dimensions & Data

Models eco-ATC-731-1g to 1411-1g

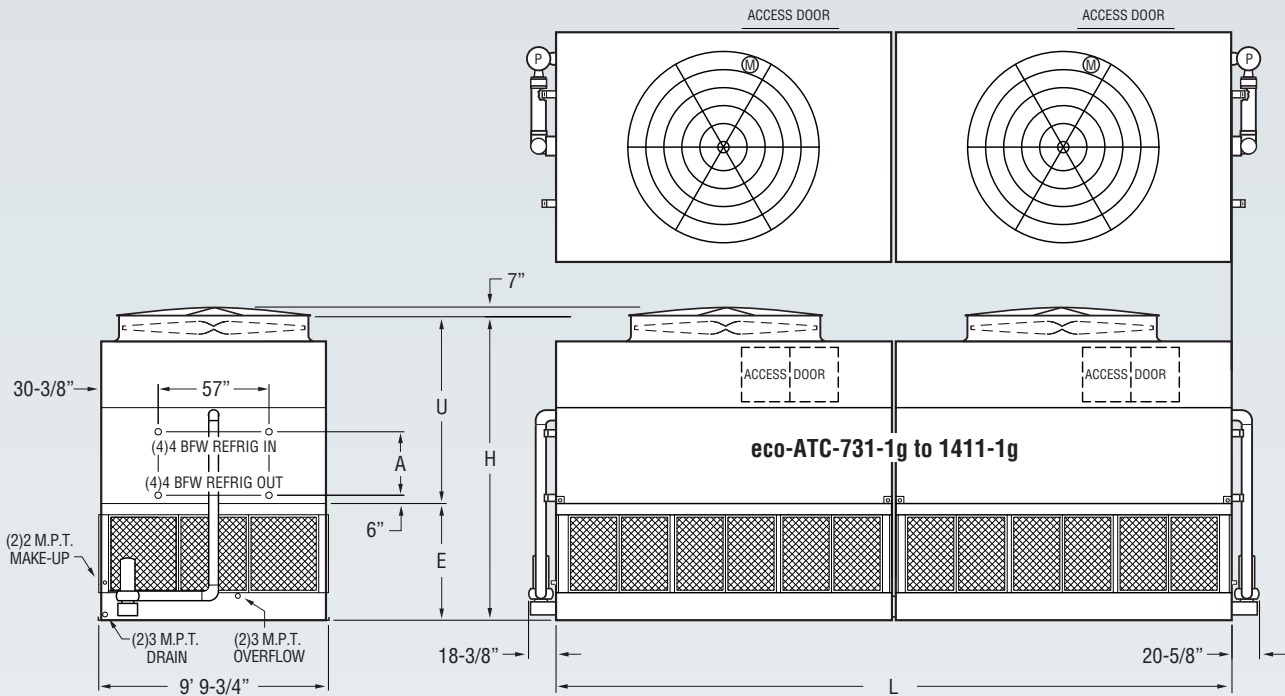

Table 11 Engineering Data

Model No.	R-717 Tons*	Fans		Weights†			Refrigerant Operating Charge lbs.***	Coil Volume ft ³	Spray Pump		Remote Pump			Dimensions				
		HP	CFM	Shipping	Heaviest Section†	Operating			HP	GPM	Gallons Req'd**	Conn. Size	Operating Weight	Height H	Upper U	Lower E	Coil A	Length L
eco-ATC-731-1g	519	(2) 10	158,500	34,600	13,650	51,880	500	68	(2) 7-1/2	2060	1260	(2) 12"	41,380	13' 9-3/8"	7' 7-1/8"	6' 2-1/4"	13-3/4"	36' 2-1/2"
eco-ATC-859-1g	610	(2) 10	156,200	41,840	17,270	59,560	734	100	(2) 7-1/2	2060	1260	(2) 12"	49,060	14' 5-7/8"	8' 3-5/8"	6' 2-1/4"	22-1/4"	36' 2-1/2"
eco-ATC-894-1g	635	(2) 25	215,100	35,040	13,870	52,320	500	68	(2) 7-1/2	2060	1260	(2) 12"	41,820	13' 9-3/8"	7' 7-1/8"	6' 2-1/4"	13-3/4"	36' 2-1/2"
eco-ATC-930-1g	660	(2) 30	228,600	35,140	13,920	52,420	500	68	(2) 7-1/2	2060	1260	(2) 12"	41,920	13' 9-3/8"	7' 7-1/8"	6' 2-1/4"	13-3/4"	36' 2-1/2"
eco-ATC-938-1g	666	(2) 15	178,800	42,100	17,400	59,820	734	100	(2) 7-1/2	2060	1260	(2) 12"	49,320	14' 5-7/8"	8' 3-5/8"	6' 2-1/4"	22-1/4"	36' 2-1/2"
eco-ATC-1004-1g	713	(2) 20	196,800	42,220	17,460	59,940	734	100	(2) 7-1/2	2060	1260	(2) 12"	49,440	14' 5-7/8"	8' 3-5/8"	6' 2-1/4"	22-1/4"	36' 2-1/2"
eco-ATC-1035-1g	735	(2) 15	176,100	49,840	21,270	68,020	969	132	(2) 7-1/2	2060	1260	(2) 12"	57,520	15' 2-3/8"	9' 1/8"	6' 2-1/4"	30-3/4"	36' 2-1/2"
eco-ATC-1054-1g	748	(2) 25	211,900	42,280	17,490	60,000	734	100	(2) 7-1/2	2060	1260	(2) 12"	49,500	14' 5-7/8"	8' 3-5/8"	6' 2-1/4"	22-1/4"	36' 2-1/2"
eco-ATC-1097-1g	779	(2) 30	225,200	42,380	17,540	60,100	734	100	(2) 7-1/2	2060	1260	(2) 12"	49,600	14' 5-7/8"	8' 3-5/8"	6' 2-1/4"	22-1/4"	36' 2-1/2"
eco-ATC-1109-1g	787	(2) 20	193,800	49,960	21,330	68,140	969	132	(2) 7-1/2	2060	1260	(2) 12"	57,640	15' 2-3/8"	9' 1/8"	6' 2-1/4"	30-3/4"	36' 2-1/2"
eco-ATC-1163-1g	825	(2) 25	208,800	50,020	21,360	68,200	969	132	(2) 7-1/2	2060	1260	(2) 12"	57,700	15' 2-3/8"	9' 1/8"	6' 2-1/4"	30-3/4"	36' 2-1/2"
eco-ATC-1166-1g	827	(2) 20	191,000	57,500	25,100	76,120	1203	164	(2) 7-1/2	2060	1260	(2) 12"	65,620	15' 10-7/8"	9' 8-5/8"	6' 2-1/4"	39-1/4"	36' 2-1/2"
eco-ATC-1211-1g	859	(2) 30	221,900	50,120	21,410	68,300	969	132	(2) 7-1/2	2060	1260	(2) 12"	57,800	15' 2-3/8"	9' 1/8"	6' 2-1/4"	30-3/4"	36' 2-1/2"
eco-ATC-1223-1g	868	(2) 25	205,700	57,560	25,130	76,180	1203	164	(2) 7-1/2	2060	1260	(2) 12"	65,680	15' 10-7/8"	9' 8-5/8"	6' 2-1/4"	39-1/4"	36' 2-1/2"
eco-ATC-1274-1g	904	(2) 30	218,600	57,660	25,180	76,280	1203	164	(2) 7-1/2	2060	1260	(2) 12"	65,780	15' 10-7/8"	9' 8-5/8"	6' 2-1/4"	39-1/4"	36' 2-1/2"
eco-ATC-1287-1g	913	(2) 40	244,200	50,440	21,570	68,620	969	132	(2) 7-1/2	2060	1260	(2) 12"	58,120	15' 2-3/8"	9' 1/8"	6' 2-1/4"	30-3/4"	36' 2-1/2"
eco-ATC-1330-1g	944	(2) 30	215,400	65,520	29,110	84,580	1437	196	(2) 7-1/2	2060	1260	(2) 12"	74,080	16' 7-3/8"	10' 5-1/8"	6' 2-1/4"	47-3/4"	36' 2-1/2"
eco-ATC-1351-1g	959	(2) 40	240,600	57,980	25,340	76,600	1203	164	(2) 7-1/2	2060	1260	(2) 12"	66,100	15' 10-7/8"	9' 8-5/8"	6' 2-1/4"	39-1/4"	36' 2-1/2"
eco-ATC-1411-1g	1001	(2) 40	237,100	65,840	29,270	84,900	1437	196	(2) 7-1/2	2060	1260	(2) 12"	74,400	16' 7-3/8"	10' 5-1/8"	6' 2-1/4"	47-3/4"	36' 2-1/2"

* Tons at standard conditions: 96.3°F condensing, 20°F suction and 78°F W.B.

** Gallons shown is water in suspension in unit and piping. Allow for additional water in bottom of remote sump to cover pump suction and strainer during operation. (12" would normally be sufficient.)

† Heaviest section is the coil section. **Weights shown are for 1g seismic design.**

*** Refrigerant charge is shown for R-717. Multiply by 1.93 for R-22 and 1.98 for R-134a.

Dimensions are subject to change. Do not use for pre-fabrication. Quantity of coil connections subject to change based on refrigerant and design conditions.

Engineering Dimensions & Data

Models eco-ATC-433-1g to 710-1g

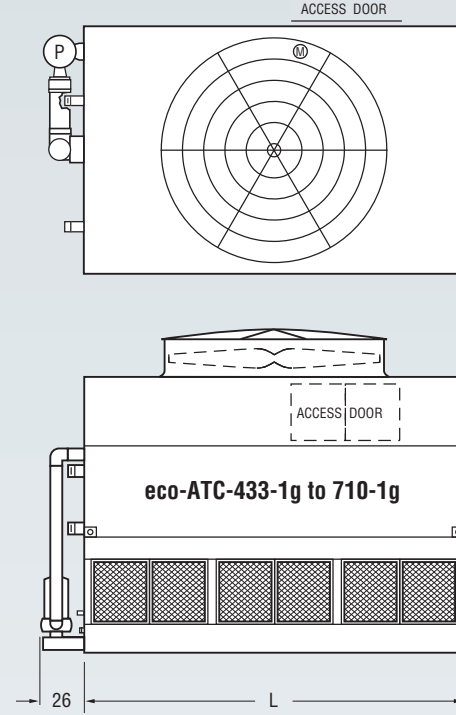
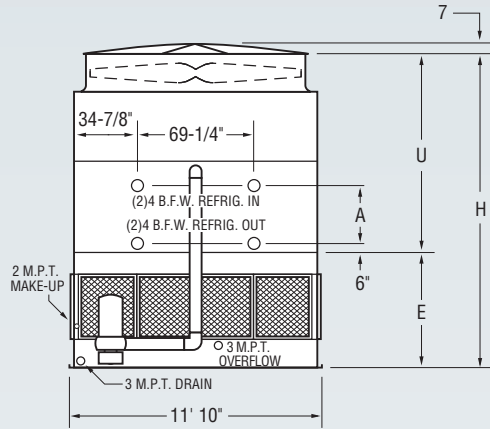

Table 12 Engineering Data

Model No.	R-717 Tons*	Fans		Weights†			Refrigerant Operating Charge lbs.***	Coil Volume ft ³	Spray Pump		Remote Pump			Dimensions				
		HP	CFM	Shipping	Heaviest Section†	Operating			HP	GPM	Gallons Req'd**	Conn. Size	Operating Weight	Height H	Upper U	Lower E	Coil A	Length L
eco-ATC-433-1g	308	15	76,000	16,950	14,240	23,560	306	42	5	800	490	12"	19,610	13' 5-7/8"	8' 3-5/8"	5' 2-1/4"	22-1/4"	11' 11-3/4"
eco-ATC-440-1g	313	10	64,500	20,010	17,300	26,810	401	55	5	800	490	12"	22,860	14' 2-3/8"	9' 1/8"	5' 2-1/4"	30-3/4"	11' 11-3/4"
eco-ATC-463-1g	329	20	83,700	17,010	14,300	23,620	306	42	5	800	490	12"	19,670	13' 5-7/8"	8' 3-5/8"	5' 2-1/4"	22-1/4"	11' 11-3/4"
eco-ATC-478-1g	340	15	73,800	20,140	17,430	26,940	401	55	5	800	490	12"	22,990	14' 2-3/8"	9' 1/8"	5' 2-1/4"	30-3/4"	11' 11-3/4"
eco-ATC-484-1g	344	25	89,200	17,040	14,330	23,650	306	42	5	800	490	12"	19,700	13' 5-7/8"	8' 3-5/8"	5' 2-1/4"	22-1/4"	11' 11-3/4"
eco-ATC-510-1g	362	20	81,200	20,200	17,490	27,000	401	55	5	800	490	12"	23,050	14' 2-3/8"	9' 1/8"	5' 2-1/4"	30-3/4"	11' 11-3/4"
eco-ATC-534-1g	379	25	86,600	20,230	17,520	27,030	401	55	5	800	490	12"	23,080	14' 2-3/8"	9' 1/8"	5' 2-1/4"	30-3/4"	11' 11-3/4"
eco-ATC-536-1g	381	20	78,900	23,230	20,520	30,210	497	68	5	800	490	12"	26,260	14' 10-7/8"	9' 8-5/8"	5' 2-1/4"	39-1/4"	11' 11-3/4"
eco-ATC-554-1g	393	30	91,100	20,280	17,570	27,080	401	55	5	800	490	12"	23,130	14' 2-3/8"	9' 1/8"	5' 2-1/4"	30-3/4"	11' 11-3/4"
eco-ATC-562-1g	399	25	84,000	23,260	20,550	30,240	497	68	5	800	490	12"	26,290	14' 10-7/8"	9' 8-5/8"	5' 2-1/4"	39-1/4"	11' 11-3/4"
eco-ATC-583-1g	414	30	88,500	23,310	20,600	30,290	497	68	5	800	490	12"	26,340	14' 10-7/8"	9' 8-5/8"	5' 2-1/4"	39-1/4"	11' 11-3/4"
eco-ATC-585-1g	415	25	81,400	26,470	23,760	33,630	593	81	5	800	490	12"	29,680	15' 7-3/8"	10' 5-1/8"	5' 2-1/4"	47-3/4"	11' 11-3/4"
eco-ATC-607-1g	431	30	85,700	26,520	23,810	33,680	593	81	5	800	490	12"	29,730	15' 7-3/8"	10' 5-1/8"	5' 2-1/4"	47-3/4"	11' 11-3/4"
eco-ATC-644-1g	457	40	92,900	26,680	23,970	33,840	593	81	5	800	490	12"	29,890	15' 7-3/8"	10' 5-1/8"	5' 2-1/4"	47-3/4"	11' 11-3/4"
eco-ATC-557-1g	396	30	105,000	19,400	16,340	27,190	355	48	5	900	570	12"	22,620	13' 11-7/8"	8' 3-5/8"	5' 8-1/4"	22-1/4"	13' 11-3/4"
eco-ATC-558-1g	396	15	79,400	26,470	23,410	34,690	578	79	5	900	570	12"	30,120	15' 4-7/8"	9' 8-5/8"	5' 8-1/4"	39-1/4"	13' 11-3/4"
eco-ATC-560-1g	398	20	90,000	23,040	19,980	31,040	466	64	5	900	570	12"	26,470	14' 8-3/8"	9' 1/8"	5' 8-1/4"	30-3/4"	13' 11-3/4"
eco-ATC-589-1g	418	25	96,800	23,070	20,010	31,070	466	64	5	900	570	12"	26,500	14' 8-3/8"	9' 1/8"	5' 8-1/4"	30-3/4"	13' 11-3/4"
eco-ATC-588-1g	418	20	87,300	26,530	23,470	34,750	578	79	5	900	570	12"	30,180	15' 4-7/8"	9' 8-5/8"	5' 8-1/4"	39-1/4"	13' 11-3/4"
eco-ATC-611-1g	434	30	101,900	23,120	20,060	31,120	466	64	5	900	570	12"	26,550	14' 8-3/8"	9' 1/8"	5' 8-1/4"	30-3/4"	13' 11-3/4"
eco-ATC-614-1g	436	20	84,600	30,570	27,510	39,000	690	94	5	900	570	12"	34,430	16' 1-3/8"	10' 5-1/8"	5' 8-1/4"	47-3/4"	13' 11-3/4"
eco-ATC-620-1g	440	25	94,000	26,560	23,500	34,780	578	79	5	900	570	12"	30,210	15' 4-7/8"	9' 8-5/8"	5' 8-1/4"	39-1/4"	13' 11-3/4"
eco-ATC-642-1g	456	30	98,900	26,610	23,550	34,830	578	79	5	900	570	12"	30,260	15' 4-7/8"	9' 8-5/8"	5' 8-1/4"	39-1/4"	13' 11-3/4"
eco-ATC-646-1g	459	25	91,100	30,600	27,540	39,030	690	94	5	900	570	12"	34,460	16' 1-3/8"	10' 5-1/8"	5' 8-1/4"	47-3/4"	13' 11-3/4"
eco-ATC-671-1g	476	30	95,800	30,650	27,590	39,080	690	94	5	900	570	12"	34,510	16' 1-3/8"	10' 5-1/8"	5' 8-1/4"	47-3/4"	13' 11-3/4"
eco-ATC-681-1g	483	40	107,200	26,770	23,710	34,990	578	79	5	900	570	12"	30,420	15' 4-7/8"	9' 8-5/8"	5' 8-1/4"	39-1/4"	13' 11-3/4"
eco-ATC-710-1g	504	40	103,800	30,810	27,750	39,240	690	94	5	900	570	12"	34,670	16' 1-3/8"	10' 5-1/8"	5' 8-1/4"	47-3/4"	13' 11-3/4"

* Tons at standard conditions: 96.3°F condensing, 20°F suction and 78°F W.B.

** Gallons shown is water in suspension in unit and piping. Allow for additional water in bottom of remote sump to cover pump suction and strainer during operation. (12" would normally be sufficient.)

† Heaviest section is the coil section. **Weights shown are for 1g seismic design.**

*** Refrigerant charge is shown for R-717. Multiply by 1.93 for R-22 and 1.98 for R-134a.

Dimensions are subject to change. Do not use for pre-fabrication. Quantity of coil connections subject to change based on refrigerant and design conditions.



Engineering Dimensions & Data

Models eco-ATC-636-1g to 1023-1g

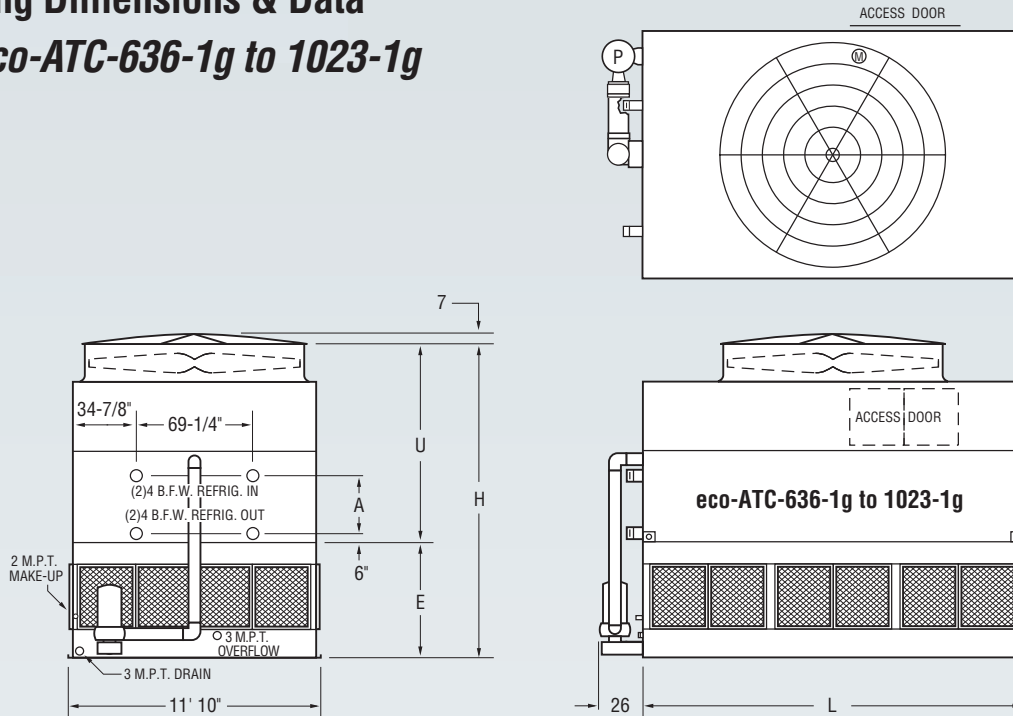

Table 13 Engineering Data

Model No.	R-717 Tons*	Fans		Weights†			Refrigerant Operating Charge lbs.***	Coil Volume ft ³	Spray Pump		Remote Pump			Dimensions				
		HP	CFM	Shipping	Heaviest Section†	Operating			HP	GPM	Gallons Req'd**	Conn. Size	Operating Weight	Height H	Upper U	Lower E	Coil A	Length L
eco-ATC-636-1g	452	20	113,300	24,300	20,380	34,260	452	62	7 1/2	1200	720	12"	28,390	14' 5-7/8"	8' 3-5/8"	6' 2-1/4"	22-1/4"	18' 0"
eco-ATC-670-1g	476	25	122,100	24,330	20,410	34,290	452	62	7 1/2	1200	720	12"	28,420	14' 5-7/8"	8' 3-5/8"	6' 2-1/4"	22-1/4"	18' 0"
eco-ATC-699-1g	496	30	129,700	24,380	20,460	34,340	452	62	7 1/2	1200	720	12"	28,470	14' 5-7/8"	8' 3-5/8"	6' 2-1/4"	22-1/4"	18' 0"
eco-ATC-702-1g	498	20	109,900	29,060	25,140	39,300	597	81	7 1/2	1200	720	12"	33,430	15' 2-3/8"	9' 1/8"	6' 2-1/4"	30-3/4"	18' 0"
eco-ATC-738-1g	524	25	118,400	29,090	25,170	39,330	597	81	7 1/2	1200	720	12"	33,460	15' 2-3/8"	9' 1/8"	6' 2-1/4"	30-3/4"	18' 0"
eco-ATC-739-1g	525	20	106,600	33,660	29,740	44,180	741	101	7 1/2	1200	720	12"	38,310	15' 10-7/8"	9' 8-5/8"	6' 2-1/4"	39-1/4"	18' 0"
eco-ATC-772-1g	548	30	126,000	29,140	25,220	39,380	597	81	7 1/2	1200	720	12"	33,510	15' 2-3/8"	9' 1/8"	6' 2-1/4"	30-3/4"	18' 0"
eco-ATC-777-1g	552	25	114,900	33,690	29,770	44,210	741	101	7 1/2	1200	720	12"	38,340	15' 10-7/8"	9' 8-5/8"	6' 2-1/4"	39-1/4"	18' 0"
eco-ATC-811-1g	576	30	122,100	33,740	29,820	44,260	741	101	7 1/2	1200	720	12"	38,390	15' 10-7/8"	9' 8-5/8"	6' 2-1/4"	39-1/4"	18' 0"
eco-ATC-812-1g	576	25	111,400	38,340	34,420	49,140	885	121	7 1/2	1200	720	12"	43,270	16' 7-3/8"	10' 5-1/8"	6' 2-1/4"	47-3/4"	18' 0"
eco-ATC-847-1g	601	30	118,400	38,390	34,470	49,190	885	121	7 1/2	1200	720	12"	43,320	16' 7-3/8"	10' 5-1/8"	6' 2-1/4"	47-3/4"	18' 0"
eco-ATC-862-1g	612	40	132,600	33,900	29,980	44,420	741	101	7 1/2	1200	720	12"	38,550	15' 10-7/8"	9' 8-5/8"	6' 2-1/4"	39-1/4"	18' 0"
eco-ATC-900-1g	639	40	128,400	38,550	34,630	49,350	885	121	7 1/2	1200	720	12"	43,480	16' 7-3/8"	10' 5-1/8"	6' 2-1/4"	47-3/4"	18' 0"
eco-ATC-942-1g	669	50	136,700	38,560	34,640	49,360	885	121	7 1/2	1200	720	12"	43,490	16' 7-3/8"	10' 5-1/8"	6' 2-1/4"	47-3/4"	18' 0"
eco-ATC-775-1g	550	40	151,900	27,080	22,570	38,260	501	68	10	1400	800	14"	31,560	14' 5-7/8"	8' 3-5/8"	6' 2-1/4"	22-1/4"	20' 0"
eco-ATC-802-1g	569	30	135,200	32,160	27,650	43,650	662	90	10	1400	800	14"	36,950	15' 2-3/8"	9' 1/8"	6' 2-1/4"	30-3/4"	20' 0"
eco-ATC-814-1g	578	25	123,300	37,230	32,720	49,020	822	112	10	1400	800	14"	42,320	15' 10-7/8"	9' 8-5/8"	6' 2-1/4"	39-1/4"	20' 0"
eco-ATC-845-1g	600	30	131,100	37,280	32,770	49,070	822	112	10	1400	800	14"	42,370	15' 10-7/8"	9' 8-5/8"	6' 2-1/4"	39-1/4"	20' 0"
eco-ATC-850-1g	603	25	119,400	42,880	38,370	54,980	983	134	10	1400	800	14"	48,280	16' 7-3/8"	10' 5-1/8"	6' 2-1/4"	47-3/4"	20' 0"
eco-ATC-856-1g	608	40	147,600	32,320	27,810	43,810	662	90	10	1400	800	14"	37,110	15' 2-3/8"	9' 1/8"	6' 2-1/4"	30-3/4"	20' 0"
eco-ATC-882-1g	626	30	126,900	42,930	38,420	55,030	983	134	10	1400	800	14"	48,330	16' 7-3/8"	10' 5-1/8"	6' 2-1/4"	47-3/4"	20' 0"
eco-ATC-901-1g	640	40	143,200	37,440	32,930	49,230	822	112	10	1400	800	14"	42,530	15' 10-7/8"	9' 8-5/8"	6' 2-1/4"	39-1/4"	20' 0"
eco-ATC-940-1g	667	40	138,600	43,090	38,580	55,190	983	134	10	1400	800	14"	48,490	16' 7-3/8"	10' 5-1/8"	6' 2-1/4"	47-3/4"	20' 0"
eco-ATC-943-1g	669	50	152,400	37,450	32,940	49,240	822	112	10	1400	800	14"	42,540	15' 10-7/8"	9' 8-5/8"	6' 2-1/4"	39-1/4"	20' 0"
eco-ATC-984-1g	698	50	147,600	43,100	38,590	55,200	983	134	10	1400	800	14"	48,500	16' 7-3/8"	10' 5-1/8"	6' 2-1/4"	47-3/4"	20' 0"
eco-ATC-1023-1g	726	60	155,300	43,300	38,790	55,400	983	134	10	1400	800	14"	48,700	16' 7-3/8"	10' 5-1/8"	6' 2-1/4"	47-3/4"	20' 0"

* Tons at standard conditions: 96.3°F condensing, 20°F suction and 78°F W.B.

** Gallons shown is water in suspension in unit and piping. Allow for additional water in bottom of remote sump to cover pump suction and strainer during operation. (12" would normally be sufficient.)

† Heaviest section is the coil section. **Weights shown are for 1g seismic design.**

*** Refrigerant charge is shown for R-717. Multiply by 1.93 for R-22 and 1.98 for R-134a.

Dimensions are subject to change. Do not use for pre-fabrication. Quantity of coil connections subject to change based on refrigerant and design conditions.

Engineering Dimensions & Data

Models eco-ATC-866-1g to 1420-1g

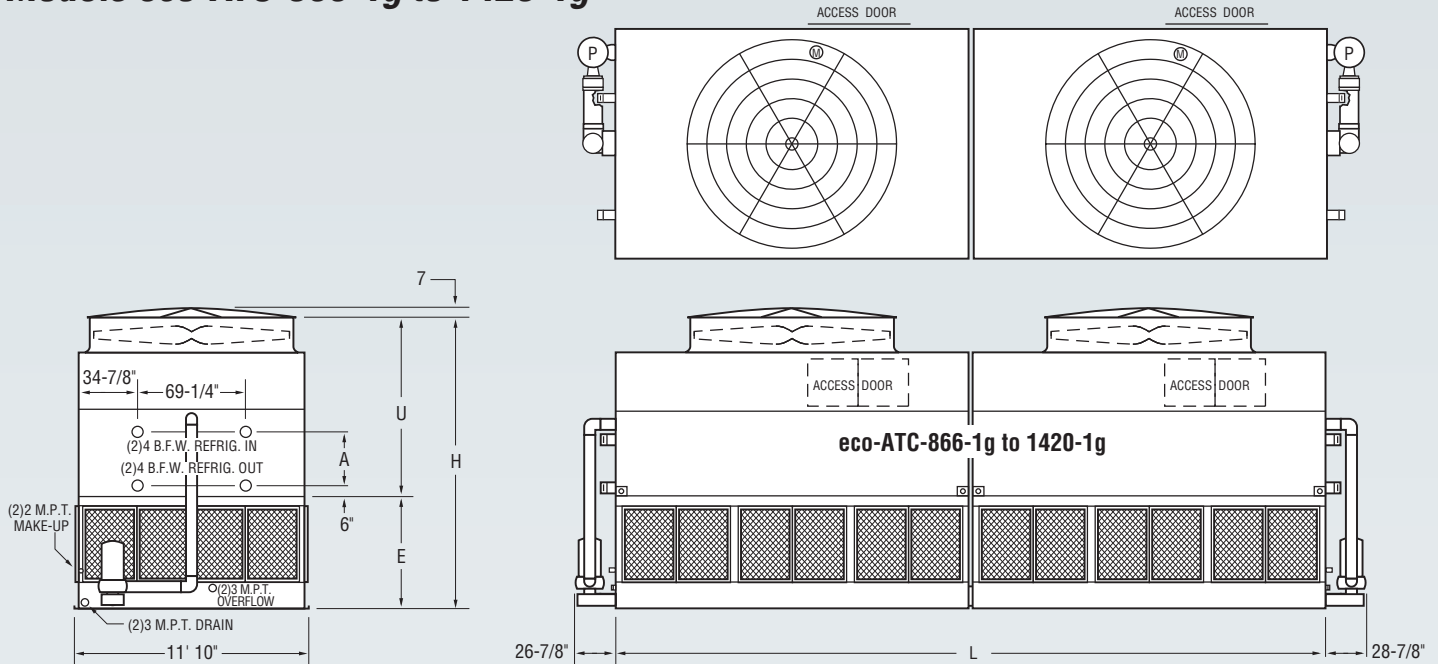

Table 14 Engineering Data

Model No.	R-717 Tons*	Fans		Weights†			Refrigerant Operating Charge lbs.***	Coil Volume ft ³	Spray Pump		Remote Pump			Dimensions				
		HP	CFM	Shipping	Heaviest Section†	Operating			HP	GPM	Gallons Req'd**	Conn. Size	Operating Weight	Height H	Upper U	Lower E	Coil A	Length L
eco-ATC-866-1g	615	(2) 15	152,000	33,900	14,240	47,120	611	83	(2) 5	1600	980	(2) 12"	39,220	14' 5-7/8"	8' 3-5/8"	6' 2-1/4"	22-1/4"	24' 2"
eco-ATC-878-1g	623	(2) 10	129,000	40,020	17,300	53,620	803	109	(2) 5	1600	980	(2) 12"	45,720	15' 2-3/8"	9' 1/8"	6' 2-1/4"	30-3/4"	24' 2"
eco-ATC-926-1g	657	(2) 20	167,400	34,020	14,300	47,240	611	83	(2) 5	1600	980	(2) 12"	39,340	14' 5-7/8"	8' 3-5/8"	6' 2-1/4"	22-1/4"	24' 2"
eco-ATC-953-1g	676	(2) 15	147,600	40,280	17,430	53,880	803	109	(2) 5	1600	980	(2) 12"	45,980	15' 2-3/8"	9' 1/8"	6' 2-1/4"	30-3/4"	24' 2"
eco-ATC-969-1g	688	(2) 25	178,400	34,080	14,330	47,300	611	83	(2) 5	1600	980	(2) 12"	39,400	14' 5-7/8"	8' 3-5/8"	6' 2-1/4"	22-1/4"	24' 2"
eco-ATC-1002-1g	711	(2) 15	143,300	46,340	20,460	60,300	994	135	(2) 5	1600	980	(2) 12"	52,400	15' 10-7/8"	9' 8-5/8"	6' 2-1/4"	39-1/4"	24' 2"
eco-ATC-1021-1g	725	(2) 20	162,500	40,400	17,490	54,000	803	109	(2) 5	1600	980	(2) 12"	46,100	15' 2-3/8"	9' 1/8"	6' 2-1/4"	30-3/4"	24' 2"
eco-ATC-1045-1g	742	(2) 15	138,900	52,760	23,670	67,080	1185	161	(2) 5	1600	980	(2) 12"	59,180	16' 7-3/8"	10' 5-1/8"	6' 2-1/4"	47-3/4"	24' 2"
eco-ATC-1068-1g	758	(2) 25	173,200	40,460	17,520	54,060	803	109	(2) 5	1600	980	(2) 12"	46,160	15' 2-3/8"	9' 1/8"	6' 2-1/4"	30-3/4"	24' 2"
eco-ATC-1072-1g	761	(2) 20	157,800	46,460	20,520	60,420	994	135	(2) 5	1600	980	(2) 12"	52,520	15' 10-7/8"	9' 8-5/8"	6' 2-1/4"	39-1/4"	24' 2"
eco-ATC-1107-1g	786	(2) 30	182,200	40,560	17,570	54,160	803	109	(2) 5	1600	980	(2) 12"	46,260	15' 2-3/8"	9' 1/8"	6' 2-1/4"	30-3/4"	24' 2"
eco-ATC-1119-1g	794	(2) 20	152,900	52,880	23,730	67,200	1185	161	(2) 5	1600	980	(2) 12"	59,300	16' 7-3/8"	10' 5-1/8"	6' 2-1/4"	47-3/4"	24' 2"
eco-ATC-1122-1g	796	(2) 25	168,000	46,520	20,550	60,480	994	135	(2) 5	1600	980	(2) 12"	52,580	15' 10-7/8"	9' 8-5/8"	6' 2-1/4"	39-1/4"	24' 2"
eco-ATC-1164-1g	826	(2) 30	177,000	46,620	20,600	60,580	994	135	(2) 5	1600	980	(2) 12"	52,680	15' 10-7/8"	9' 8-5/8"	6' 2-1/4"	39-1/4"	24' 2"
eco-ATC-1171-1g	831	(2) 25	162,700	52,940	23,760	67,260	1185	161	(2) 5	1600	980	(2) 12"	59,360	16' 7-3/8"	10' 5-1/8"	6' 2-1/4"	47-3/4"	24' 2"
eco-ATC-1214-1g	861	(2) 30	171,500	53,040	23,810	67,360	1185	161	(2) 5	1600	980	(2) 12"	59,460	16' 7-3/8"	10' 5-1/8"	6' 2-1/4"	47-3/4"	24' 2"
eco-ATC-1288-1g	914	(2) 40	185,700	53,360	23,970	67,680	1185	161	(2) 5	1600	980	(2) 12"	59,780	16' 7-3/8"	10' 5-1/8"	6' 2-1/4"	47-3/4"	24' 2"
eco-ATC-1176-1g	835	(2) 20	174,700	53,060	23,470	69,500	1157	158	(2) 5	1800	1140	(2) 12"	60,360	16' 10-7/8"	9' 8-5/8"	7' 2-1/4"	39-1/4"	28' 2"
eco-ATC-1178-1g	836	(2) 25	193,700	46,140	20,010	62,140	933	127	(2) 5	1800	1140	(2) 12"	53,000	16' 2-3/8"	9' 1/8"	7' 2-1/4"	30-3/4"	28' 2"
eco-ATC-1227-1g	871	(2) 20	169,200	61,140	27,510	78,000	1380	188	(2) 5	1800	1140	(2) 12"	68,860	17' 7-3/8"	10' 5-1/8"	7' 2-1/4"	47-3/4"	28' 2"
eco-ATC-1238-1g	879	(2) 25	187,900	53,120	23,500	69,560	1157	158	(2) 5	1800	1140	(2) 12"	60,420	16' 10-7/8"	9' 8-5/8"	7' 2-1/4"	39-1/4"	28' 2"
eco-ATC-1285-1g	912	(2) 30	197,700	53,220	23,550	69,660	1157	158	(2) 5	1800	1140	(2) 12"	60,520	16' 10-7/8"	9' 8-5/8"	7' 2-1/4"	39-1/4"	28' 2"
eco-ATC-1292-1g	917	(2) 25	182,100	61,200	27,540	78,060	1380	188	(2) 5	1800	1140	(2) 12"	68,920	17' 7-3/8"	10' 5-1/8"	7' 2-1/4"	47-3/4"	28' 2"
eco-ATC-1341-1g	952	(2) 30	191,600	61,300	27,590	78,160	1380	188	(2) 5	1800	1140	(2) 12"	69,020	17' 7-3/8"	10' 5-1/8"	7' 2-1/4"	47-3/4"	28' 2"
eco-ATC-1361-1g	966	(2) 40	214,400	53,540	23,710	69,980	1157	158	(2) 5	1800	1140	(2) 12"	60,840	16' 10-7/8"	9' 8-5/8"	7' 2-1/4"	39-1/4"	28' 2"
eco-ATC-1420-1g	1008	(2) 40	207,600	61,620	27,750	78,480	1380	188	(2) 5	1800	1140	(2) 12"	69,340	17' 7-3/8"	10' 5-1/8"	7' 2-1/4"	47-3/4"	28' 2"

* Tons at standard conditions: 96.3°F condensing, 20°F suction and 78°F W.B.
 ** Gallons shown is water in suspension in unit and piping. Allow for additional water in bottom of remote sump to cover pump suction and strainer during operation. (12" would normally be sufficient.)
 † Heaviest section is the coil section. **Weights shown are for 1g seismic design.**
 *** Refrigerant charge is shown for R-717. Multiply by 1.93 for R-22 and 1.98 for R-134a.
 Dimensions are subject to change. Do not use for pre-fabrication. Quantity of coil connections subject to change based on refrigerant and design conditions.



Engineering Dimensions & Data

Models eco-ATC-1186-1g to 2043-1g

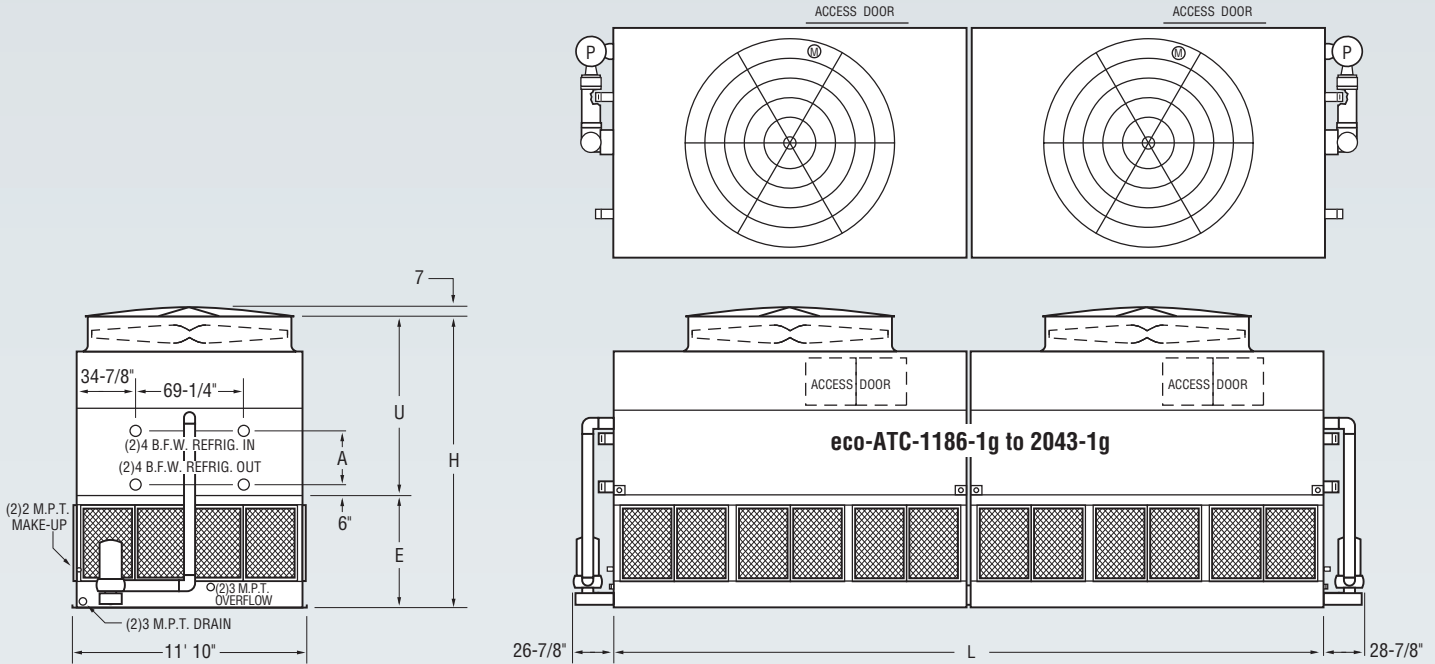

Table 15 Engineering Data

Model No.	R-717 Tons*	Fans		Weights†			Refrigerant Operating Charge lbs.***	Coil Volume ft ³	Spray Pump		Remote Pump			Dimensions				
		HP	CFM	Shipping	Heaviest Section†	Operating			HP	GPM	Gallons Req'd**	Conn. Size	Operating Weight	Height H	Upper U	Lower E	Coil A	Length L
eco-ATC-1186-1g	842	(2) 30	266,900	39,600	15,880	58,980	616	84	(2) 7-1/2	2400	1440	(2) 12"	47,240	14' 9-3/8"	7' 7-1/8"	7' 2-1/4"	13-3/4"	36' 2-1/2"
eco-ATC-1272-1g	903	(2) 20	226,700	48,600	20,380	68,520	904	123	(2) 7-1/2	2400	1440	(2) 12"	56,780	15' 5-7/8"	8' 3-5/8"	7' 2-1/4"	22-1/4"	36' 2-1/2"
eco-ATC-1339-1g	950	(2) 25	244,200	48,660	20,410	68,580	904	123	(2) 7-1/2	2400	1440	(2) 12"	56,840	15' 5-7/8"	8' 3-5/8"	7' 2-1/4"	22-1/4"	36' 2-1/2"
eco-ATC-1399-1g	993	(2) 30	259,500	48,760	20,460	68,680	904	123	(2) 7-1/2	2400	1440	(2) 12"	56,940	15' 5-7/8"	8' 3-5/8"	7' 2-1/4"	22-1/4"	36' 2-1/2"
eco-ATC-1404-1g	996	(2) 20	220,100	58,120	25,140	78,600	1193	163	(2) 7-1/2	2400	1440	(2) 12"	66,860	16' 2-3/8"	9' 1/8"	7' 2-1/4"	30-3/4"	36' 2-1/2"
eco-ATC-1477-1g	1048	(2) 20	213,300	67,320	29,740	88,360	1482	202	(2) 7-1/2	2400	1440	(2) 12"	76,620	16' 10-7/8"	9' 8-5/8"	7' 2-1/4"	39-1/4"	36' 2-1/2"
eco-ATC-1479-1g	1049	(2) 25	236,700	58,180	25,170	78,660	1193	163	(2) 7-1/2	2400	1440	(2) 12"	66,920	16' 2-3/8"	9' 1/8"	7' 2-1/4"	30-3/4"	36' 2-1/2"
eco-ATC-1545-1g	1096	(2) 30	252,000	58,280	25,220	78,760	1193	163	(2) 7-1/2	2400	1440	(2) 12"	67,020	16' 2-3/8"	9' 1/8"	7' 2-1/4"	30-3/4"	36' 2-1/2"
eco-ATC-1555-1g	1103	(2) 25	229,800	67,380	29,770	88,420	1482	202	(2) 7-1/2	2400	1440	(2) 12"	76,680	16' 10-7/8"	9' 8-5/8"	7' 2-1/4"	39-1/4"	36' 2-1/2"
eco-ATC-1624-1g	1152	(2) 30	244,200	67,480	29,820	88,520	1482	202	(2) 7-1/2	2400	1440	(2) 12"	76,780	16' 10-7/8"	9' 8-5/8"	7' 2-1/4"	39-1/4"	36' 2-1/2"
eco-ATC-1696-1g	1203	(2) 30	236,700	76,780	34,470	98,380	1771	241	(2) 7-1/2	2400	1440	(2) 12"	86,640	17' 7-3/8"	10' 5-1/8"	7' 2-1/4"	47-3/4"	36' 2-1/2"
eco-ATC-1724-1g	1223	(2) 40	265,100	67,800	29,980	88,840	1482	202	(2) 7-1/2	2400	1440	(2) 12"	77,100	16' 10-7/8"	9' 8-5/8"	7' 2-1/4"	39-1/4"	36' 2-1/2"
eco-ATC-1799-1g	1276	(2) 40	256,800	77,100	34,630	98,700	1771	241	(2) 7-1/2	2400	1440	(2) 12"	86,960	17' 7-3/8"	10' 5-1/8"	7' 2-1/4"	47-3/4"	36' 2-1/2"
eco-ATC-1883-1g	1336	(2) 50	273,400	77,120	34,640	98,720	1771	241	(2) 7-1/2	2400	1440	(2) 12"	86,980	17' 7-3/8"	10' 5-1/8"	7' 2-1/4"	47-3/4"	36' 2-1/2"
eco-ATC-1607-1g	1140	(2) 30	270,400	64,320	27,650	87,300	1323	180	(2) 10	2800	1600	(2) 14"	73,900	16' 2-3/8"	9' 1/8"	7' 2-1/4"	30-3/4"	40' 2-1/2"
eco-ATC-1628-1g	1155	(2) 25	246,600	74,460	32,720	98,040	1645	224	(2) 10	2800	1600	(2) 14"	84,640	16' 10-7/8"	9' 8-5/8"	7' 2-1/4"	39-1/4"	40' 2-1/2"
eco-ATC-1691-1g	1200	(2) 30	262,100	74,560	32,770	98,140	1645	224	(2) 10	2800	1600	(2) 14"	84,740	16' 10-7/8"	9' 8-5/8"	7' 2-1/4"	39-1/4"	40' 2-1/2"
eco-ATC-1713-1g	1215	(2) 40	295,100	64,640	27,810	87,620	1323	180	(2) 10	2800	1600	(2) 14"	74,220	16' 2-3/8"	9' 1/8"	7' 2-1/4"	30-3/4"	40' 2-1/2"
eco-ATC-1801-1g	1278	(2) 40	286,400	74,880	32,930	98,460	1645	224	(2) 10	2800	1600	(2) 14"	85,060	16' 10-7/8"	9' 8-5/8"	7' 2-1/4"	39-1/4"	40' 2-1/2"
eco-ATC-1881-1g	1335	(2) 40	277,100	86,180	38,580	110,380	1966	268	(2) 10	2800	1600	(2) 14"	96,980	17' 7-3/8"	10' 5-1/8"	7' 2-1/4"	47-3/4"	40' 2-1/2"
eco-ATC-1885-1g	1337	(2) 50	304,800	74,900	32,940	98,480	1645	224	(2) 10	2800	1600	(2) 14"	85,080	16' 10-7/8"	9' 8-5/8"	7' 2-1/4"	39-1/4"	40' 2-1/2"
eco-ATC-1968-1g	1396	(2) 50	295,100	86,200	38,590	110,400	1966	268	(2) 10	2800	1600	(2) 14"	97,000	17' 7-3/8"	10' 5-1/8"	7' 2-1/4"	47-3/4"	40' 2-1/2"
eco-ATC-2043-1g	1449	(2) 60	310,600	86,600	38,790	110,800	1966	268	(2) 10	2800	1600	(2) 14"	97,400	17' 7-3/8"	10' 5-1/8"	7' 2-1/4"	47-3/4"	40' 2-1/2"

* Tons at standard conditions: 96.3°F condensing, 20°F suction and 78°F W.B.

** Gallons shown is water in suspension in unit and piping. Allow for additional water in bottom of remote sump to cover pump suction and strainer during operation. (12" would normally be sufficient.)

† Heaviest section is the coil section. **Weights shown are for 1g seismic design.**

*** Refrigerant charge is shown for R-717. Multiply by 1.93 for R-22 and 1.98 for R-134a.

Dimensions are subject to change. Do not use for pre-fabrication. Quantity of coil connections subject to change based on refrigerant and design conditions.

Engineering Dimensions & Data

Models eco-ATC-867-1g to 1421-1g

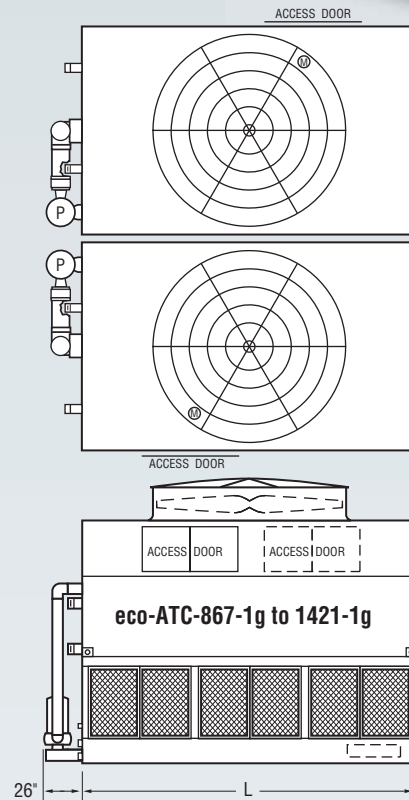
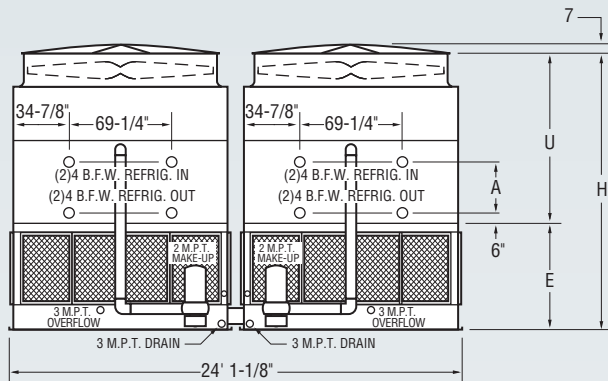

Table 16 Engineering Data

Model No.	R-717 Tons*	Fans		Weights†			Refrigerant Operating Charge lbs.***	Coil Volume ft ³	Spray Pump		Remote Pump			Dimensions				
		HP	CFM	Shipping	Heaviest Section†	Operating			HP	GPM	Gallons Req'd**	Conn. Size	Operating Weight	Height H	Upper U	Lower E	Coil A	Length L
eco-ATC-867-1g	615	(2) 15	152,000	33,900	14,240	47,120	611	83	(2) 5	1600	980	(2) 12"	39,220	14' 5-7/8"	8' 3-5/8"	6' 2-1/4"	22-1/4"	11' 11-3/4"
eco-ATC-881-1g	625	(2) 10	129,000	40,020	17,300	53,620	803	109	(2) 5	1600	980	(2) 12"	45,720	15' 2-3/8"	9' 1/8"	6' 2-1/4"	30-3/4"	11' 11-3/4"
eco-ATC-927-1g	658	(2) 20	167,400	34,020	14,300	47,240	611	83	(2) 5	1600	980	(2) 12"	39,340	14' 5-7/8"	8' 3-5/8"	6' 2-1/4"	22-1/4"	11' 11-3/4"
eco-ATC-954-1g	677	(2) 15	147,600	40,280	17,430	53,880	803	109	(2) 5	1600	980	(2) 12"	45,980	15' 2-3/8"	9' 1/8"	6' 2-1/4"	30-3/4"	11' 11-3/4"
eco-ATC-1003-1g	712	(2) 15	143,300	46,340	20,460	60,300	994	135	(2) 5	1600	980	(2) 12"	52,400	15' 10-7/8"	9' 8-5/8"	6' 2-1/4"	39-1/4"	11' 11-3/4"
eco-ATC-1022-1g	725	(2) 20	162,500	40,400	17,490	54,000	803	109	(2) 5	1600	980	(2) 12"	46,100	15' 2-3/8"	9' 1/8"	6' 2-1/4"	30-3/4"	11' 11-3/4"
eco-ATC-1046-1g	742	(2) 15	138,900	52,760	23,670	67,080	1185	161	(2) 5	1600	980	(2) 12"	59,180	16' 7-3/8"	10' 5-1/8"	6' 2-1/4"	47-3/4"	11' 11-3/4"
eco-ATC-1069-1g	759	(2) 25	173,200	40,460	17,520	54,060	803	109	(2) 5	1600	980	(2) 12"	46,160	15' 2-3/8"	9' 1/8"	6' 2-1/4"	30-3/4"	11' 11-3/4"
eco-ATC-1073-1g	761	(2) 20	157,800	46,460	20,520	60,420	994	135	(2) 5	1600	980	(2) 12"	52,520	15' 10-7/8"	9' 8-5/8"	6' 2-1/4"	39-1/4"	11' 11-3/4"
eco-ATC-1108-1g	786	(2) 30	182,200	40,560	17,570	54,160	803	109	(2) 5	1600	980	(2) 12"	46,260	15' 2-3/8"	9' 1/8"	6' 2-1/4"	30-3/4"	11' 11-3/4"
eco-ATC-1120-1g	795	(2) 20	152,900	52,880	23,730	67,200	1185	161	(2) 5	1600	980	(2) 12"	59,300	16' 7-3/8"	10' 5-1/8"	6' 2-1/4"	47-3/4"	11' 11-3/4"
eco-ATC-1123-1g	797	(2) 25	168,000	46,520	20,550	60,480	994	135	(2) 5	1600	980	(2) 12"	52,580	15' 10-7/8"	9' 8-5/8"	6' 2-1/4"	39-1/4"	11' 11-3/4"
eco-ATC-1165-1g	827	(2) 30	177,000	46,620	20,600	60,580	994	135	(2) 5	1600	980	(2) 12"	52,680	15' 10-7/8"	9' 8-5/8"	6' 2-1/4"	39-1/4"	11' 11-3/4"
eco-ATC-1172-1g	832	(2) 25	162,700	52,940	23,760	67,260	1185	161	(2) 5	1600	980	(2) 12"	59,360	16' 7-3/8"	10' 5-1/8"	6' 2-1/4"	47-3/4"	11' 11-3/4"
eco-ATC-1215-1g	862	(2) 30	171,500	53,040	23,810	67,360	1185	161	(2) 5	1600	980	(2) 12"	59,460	16' 7-3/8"	10' 5-1/8"	6' 2-1/4"	47-3/4"	11' 11-3/4"
eco-ATC-1289-1g	915	(2) 40	185,700	53,360	23,970	67,680	1185	161	(2) 5	1600	980	(2) 12"	59,780	16' 7-3/8"	10' 5-1/8"	6' 2-1/4"	47-3/4"	11' 11-3/4"
eco-ATC-1177-1g	835	(2) 20	174,700	53,060	23,470	69,500	1157	158	(2) 5	1800	1140	(2) 12"	60,360	16' 10-7/8"	9' 8-5/8"	7' 2-1/4"	39-1/4"	13' 11-3/4"
eco-ATC-1179-1g	837	(2) 25	193,700	46,140	20,010	62,140	933	127	(2) 5	1800	1140	(2) 12"	53,000	16' 2-3/8"	9' 1/8"	7' 2-1/4"	30-3/4"	13' 11-3/4"
eco-ATC-1228-1g	871	(2) 20	169,200	61,140	27,510	78,000	1380	188	(2) 5	1800	1140	(2) 12"	68,860	17' 7-3/8"	10' 5-1/8"	7' 2-1/4"	47-3/4"	13' 11-3/4"
eco-ATC-1239-1g	879	(2) 25	187,900	53,120	23,500	69,560	1157	158	(2) 5	1800	1140	(2) 12"	60,420	16' 10-7/8"	9' 8-5/8"	7' 2-1/4"	39-1/4"	13' 11-3/4"
eco-ATC-1286-1g	913	(2) 30	197,700	53,220	23,550	69,660	1157	158	(2) 5	1800	1140	(2) 12"	60,520	16' 10-7/8"	9' 8-5/8"	7' 2-1/4"	39-1/4"	13' 11-3/4"
eco-ATC-1293-1g	918	(2) 25	182,100	61,200	27,540	78,060	1380	188	(2) 5	1800	1140	(2) 12"	68,920	17' 7-3/8"	10' 5-1/8"	7' 2-1/4"	47-3/4"	13' 11-3/4"
eco-ATC-1342-1g	952	(2) 30	191,600	61,300	27,590	78,160	1380	188	(2) 5	1800	1140	(2) 12"	69,020	17' 7-3/8"	10' 5-1/8"	7' 2-1/4"	47-3/4"	13' 11-3/4"
eco-ATC-1362-1g	966	(2) 40	214,400	53,540	23,710	69,980	1157	158	(2) 5	1800	1140	(2) 12"	60,840	16' 10-7/8"	9' 8-5/8"	7' 2-1/4"	39-1/4"	13' 11-3/4"
eco-ATC-1421-1g	1008	(2) 40	207,600	61,620	27,750	78,480	1380	188	(2) 5	1800	1140	(2) 12"	69,340	17' 7-3/8"	10' 5-1/8"	7' 2-1/4"	47-3/4"	13' 11-3/4"

* Tons at standard conditions: 96.3°F condensing, 20°F suction and 78°F W.B.

** Gallons shown is water in suspension in unit and piping. Allow for additional water in bottom of remote sump to cover pump suction and strainer during operation. (12" would normally be sufficient.)

† Heaviest section is the coil section. **Weights shown are for 1g seismic design.**

*** Refrigerant charge is shown for R-717. Multiply by 1.93 for R-22 and 1.98 for R-134a.

Dimensions are subject to change. Do not use for pre-fabrication. Quantity of coil connections subject to change based on refrigerant and design conditions.



Engineering Dimensions & Data

Models eco-ATC-1187-1g to 2044-1g

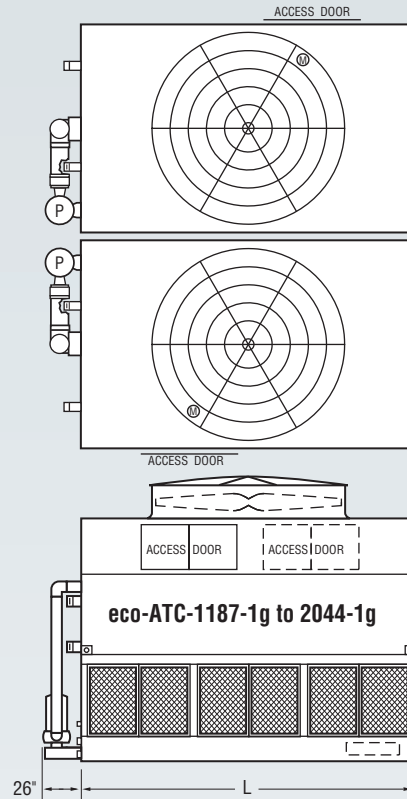
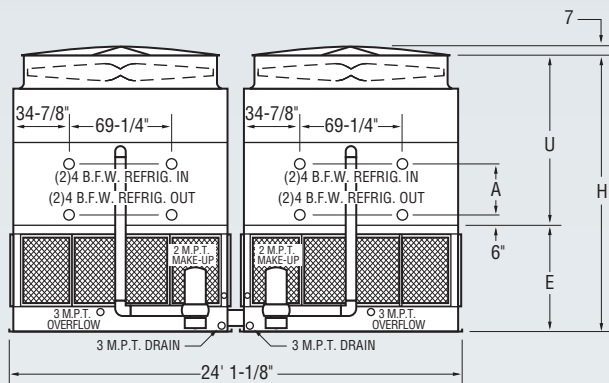

Table 17 Engineering Data

Model No.	R-717 Tons*	Fans		Weights†			Refrigerant Operating Charge lbs.***	Coil Volume ft ³	Spray Pump		Remote Pump			Dimensions				
		HP	CFM	Shipping	Heaviest Section†	Operating			HP	GPM	Gallons Req'd**	Conn. Size	Operating Weight	Height H	Upper U	Lower E	Coil A	Length L
eco-ATC-1187-1g	842	(2) 30	266,900	39,600	15,880	58,980	616	84	(2) 7-1/2	2400	1440	(2) 12"	47,240	15' 9-3/8"	7' 7-1/8"	8' 2-1/4"	13-3/4"	18' 0"
eco-ATC-1273-1g	903	(2) 20	226,700	48,600	20,380	68,520	904	123	(2) 7-1/2	2400	1440	(2) 12"	56,780	16' 5-7/8"	8' 3-5/8"	8' 2-1/4"	22-1/4"	18' 0"
eco-ATC-1340-1g	951	(2) 25	244,200	48,660	20,410	68,580	904	123	(2) 7-1/2	2400	1440	(2) 12"	56,840	16' 5-7/8"	8' 3-5/8"	8' 2-1/4"	22-1/4"	18' 0"
eco-ATC-1400-1g	993	(2) 30	259,500	48,760	20,460	68,680	904	123	(2) 7-1/2	2400	1440	(2) 12"	56,940	16' 5-7/8"	8' 3-5/8"	8' 2-1/4"	22-1/4"	18' 0"
eco-ATC-1405-1g	997	(2) 20	220,100	58,120	25,140	78,600	1193	163	(2) 7-1/2	2400	1440	(2) 12"	66,860	17' 2-3/8"	9' 1/8"	8' 2-1/4"	30-3/4"	18' 0"
eco-ATC-1478-1g	1049	(2) 20	213,300	67,320	29,740	88,360	1482	202	(2) 7-1/2	2400	1440	(2) 12"	76,620	17' 10-7/8"	9' 8-5/8"	8' 2-1/4"	39-1/4"	18' 0"
eco-ATC-1480-1g	1050	(2) 25	236,700	58,180	25,170	78,660	1193	163	(2) 7-1/2	2400	1440	(2) 12"	66,920	17' 2-3/8"	9' 1/8"	8' 2-1/4"	30-3/4"	18' 0"
eco-ATC-1546-1g	1097	(2) 30	252,000	58,280	25,220	78,760	1193	163	(2) 7-1/2	2400	1440	(2) 12"	67,020	17' 2-3/8"	9' 1/8"	8' 2-1/4"	30-3/4"	18' 0"
eco-ATC-1556-1g	1104	(2) 25	229,800	67,380	29,770	88,420	1482	202	(2) 7-1/2	2400	1440	(2) 12"	76,680	17' 10-7/8"	9' 8-5/8"	8' 2-1/4"	39-1/4"	18' 0"
eco-ATC-1625-1g	1153	(2) 30	244,200	67,480	29,820	88,520	1482	202	(2) 7-1/2	2400	1440	(2) 12"	76,780	17' 10-7/8"	9' 8-5/8"	8' 2-1/4"	39-1/4"	18' 0"
eco-ATC-1697-1g	1204	(2) 30	236,700	76,780	34,470	98,380	1771	241	(2) 7-1/2	2400	1440	(2) 12"	86,640	18' 7-3/8"	10' 5-1/8"	8' 2-1/4"	47-3/4"	18' 0"
eco-ATC-1725-1g	1224	(2) 40	265,100	67,800	29,980	88,840	1482	202	(2) 7-1/2	2400	1440	(2) 12"	77,100	17' 10-7/8"	9' 8-5/8"	8' 2-1/4"	39-1/4"	18' 0"
eco-ATC-1800-1g	1277	(2) 40	256,800	77,100	34,630	98,700	1771	241	(2) 7-1/2	2400	1440	(2) 12"	86,960	18' 7-3/8"	10' 5-1/8"	8' 2-1/4"	47-3/4"	18' 0"
eco-ATC-1884-1g	1337	(2) 50	273,400	77,120	34,640	98,720	1771	241	(2) 7-1/2	2400	1440	(2) 12"	86,980	18' 7-3/8"	10' 5-1/8"	8' 2-1/4"	47-3/4"	18' 0"
eco-ATC-1608-1g	1141	(2) 30	269,000	64,320	27,650	87,300	1323	180	(2) 10	2800	1600	(2) 14"	73,900	17' 2-3/8"	9' 1/8"	8' 2-1/4"	30-3/4"	20' 0"
eco-ATC-1629-1g	1156	(2) 25	245,400	74,460	32,720	98,040	1645	224	(2) 10	2800	1600	(2) 14"	84,640	17' 10-7/8"	9' 8-5/8"	8' 2-1/4"	39-1/4"	20' 0"
eco-ATC-1692-1g	1200	(2) 30	260,800	74,560	32,770	98,140	1645	224	(2) 10	2800	1600	(2) 14"	84,740	17' 10-7/8"	9' 8-5/8"	8' 2-1/4"	39-1/4"	20' 0"
eco-ATC-1714-1g	1216	(2) 40	293,600	64,640	27,810	87,620	1323	180	(2) 10	2800	1600	(2) 14"	74,220	17' 2-3/8"	9' 1/8"	8' 2-1/4"	30-3/4"	20' 0"
eco-ATC-1802-1g	1279	(2) 40	284,900	74,880	32,930	98,460	1645	224	(2) 10	2800	1600	(2) 14"	85,060	17' 10-7/8"	9' 8-5/8"	8' 2-1/4"	39-1/4"	20' 0"
eco-ATC-1882-1g	1335	(2) 40	275,800	86,180	38,580	110,380	1966	268	(2) 10	2800	1600	(2) 14"	96,980	18' 7-3/8"	10' 5-1/8"	8' 2-1/4"	47-3/4"	20' 0"
eco-ATC-1886-1g	1338	(2) 50	303,300	74,900	32,940	98,480	1645	224	(2) 10	2800	1600	(2) 14"	85,080	17' 10-7/8"	9' 8-5/8"	8' 2-1/4"	39-1/4"	20' 0"
eco-ATC-1969-1g	1397	(2) 50	293,600	86,200	38,590	110,400	1966	268	(2) 10	2800	1600	(2) 14"	97,000	18' 7-3/8"	10' 5-1/8"	8' 2-1/4"	47-3/4"	20' 0"
eco-ATC-2044-1g	1450	(2) 60	309,100	86,600	38,790	110,800	1966	268	(2) 10	2800	1600	(2) 14"	97,400	18' 7-3/8"	10' 5-1/8"	8' 2-1/4"	47-3/4"	20' 0"

* Tons at standard conditions: 96.3°F condensing, 20°F suction and 78°F W.B.

** Gallons shown is water in suspension in unit and piping. Allow for additional water in bottom of remote sump to cover pump suction and strainer during operation. (12" would normally be sufficient.)

† Heaviest section is the coil section. **Weights shown are for 1g seismic design.**

*** Refrigerant charge is shown for R-717. Multiply by 1.93 for R-22 and 1.98 for R-134a.

Dimensions are subject to change. Do not use for pre-fabrication. Quantity of coil connections subject to change based on refrigerant and design conditions.

Engineering Dimensions & Data

Models eco-ATC-1844-1g to 2841-1g

Models eco-ATC-1844-1g to 2841-1g

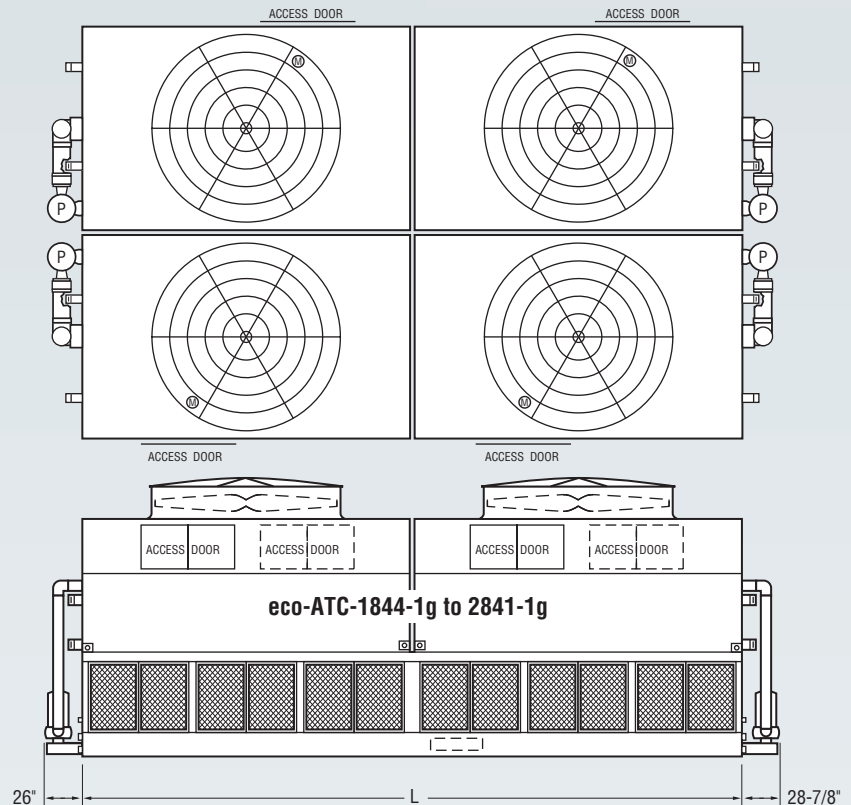
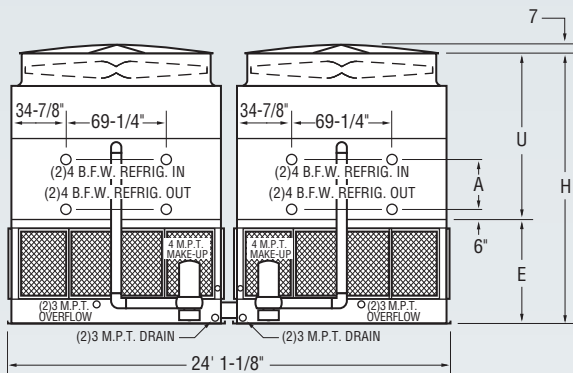

Table 18 Engineering Data

Model No.	R-717 Tons*	Fans		Weights†			Refrigerant Operating Charge lbs.***	Coil Volume ft ³	Spray Pump		Remote Pump			Dimensions				
		HP	CFM	Shipping	Heaviest Section†	Operating			HP	GPM	Gallons Req'd**	Conn. Size	Operating Weight	Height H	Upper U	Lower E	Coil A	Length L
eco-ATC-1844-1g	1308	(4) 10	250,300	92,500	20,330	120,440	1988	271	(4) 5	3200	1960	(4) 12"	104,380	17' 10-7/8"	9' 8-5/8"	8' 2-1/4"	39-1/4"	24' 2"
eco-ATC-1908-1g	1354	(4) 15	295,300	80,900	17,430	108,120	1605	219	(4) 5	3200	1960	(4) 12"	92,060	17' 2-3/8"	9' 1/8"	8' 2-1/4"	30-3/4"	24' 2"
eco-ATC-2004-1g	1422	(4) 15	286,600	93,020	20,460	120,960	1988	271	(4) 5	3200	1960	(4) 12"	104,900	17' 10-7/8"	9' 8-5/8"	8' 2-1/4"	39-1/4"	24' 2"
eco-ATC-2042-1g	1449	(4) 20	324,900	81,140	17,490	108,360	1605	219	(4) 5	3200	1960	(4) 12"	92,300	17' 2-3/8"	9' 1/8"	8' 2-1/4"	30-3/4"	24' 2"
eco-ATC-2136-1g	1515	(4) 25	346,400	81,260	17,520	108,480	1605	219	(4) 5	3200	1960	(4) 12"	92,420	17' 2-3/8"	9' 1/8"	8' 2-1/4"	30-3/4"	24' 2"
eco-ATC-2145-1g	1522	(4) 20	315,600	93,260	20,520	121,200	1988	271	(4) 5	3200	1960	(4) 12"	105,140	17' 10-7/8"	9' 8-5/8"	8' 2-1/4"	39-1/4"	24' 2"
eco-ATC-2237-1g	1587	(4) 20	305,700	106,100	23,730	134,760	2370	323	(4) 5	3200	1960	(4) 12"	118,700	18' 7-3/8"	10' 5-1/8"	8' 2-1/4"	47-3/4"	24' 2"
eco-ATC-2244-1g	1592	(4) 25	336,000	93,380	20,550	121,320	1988	271	(4) 5	3200	1960	(4) 12"	105,260	17' 10-7/8"	9' 8-5/8"	8' 2-1/4"	39-1/4"	24' 2"
eco-ATC-2327-1g	1651	(4) 30	354,000	93,580	20,600	121,520	1988	271	(4) 5	3200	1960	(4) 12"	105,460	17' 10-7/8"	9' 8-5/8"	8' 2-1/4"	39-1/4"	24' 2"
eco-ATC-2341-1g	1661	(4) 25	325,500	106,220	23,760	134,880	2370	323	(4) 5	3200	1960	(4) 12"	118,820	18' 7-3/8"	10' 5-1/8"	8' 2-1/4"	47-3/4"	24' 2"
eco-ATC-2428-1g	1722	(4) 30	342,900	106,420	23,810	135,080	2370	323	(4) 5	3200	1960	(4) 12"	119,020	18' 7-3/8"	10' 5-1/8"	8' 2-1/4"	47-3/4"	24' 2"
eco-ATC-2572-1g	1825	(4) 40	371,400	107,060	23,970	135,720	2370	323	(4) 5	3200	1960	(4) 12"	119,660	18' 7-3/8"	10' 5-1/8"	8' 2-1/4"	47-3/4"	24' 2"
eco-ATC-2353-1g	1669	(4) 20	344,100	106,320	23,470	139,340	2313	315	(4) 5	3600	2280	(4) 12"	120,780	17' 10-7/8"	9' 8-5/8"	8' 2-1/4"	39-1/4"	28' 2"
eco-ATC-2357-1g	1672	(4) 25	381,500	92,480	20,010	124,620	1866	254	(4) 5	3600	2280	(4) 12"	106,060	17' 2-3/8"	9' 1/8"	8' 2-1/4"	30-3/4"	28' 2"
eco-ATC-2444-1g	1734	(4) 30	401,600	92,680	20,060	124,820	1866	254	(4) 5	3600	2280	(4) 12"	106,260	17' 2-3/8"	9' 1/8"	8' 2-1/4"	30-3/4"	28' 2"
eco-ATC-2477-1g	1757	(4) 25	370,200	106,440	23,500	139,460	2313	315	(4) 5	3600	2280	(4) 12"	120,900	17' 10-7/8"	9' 8-5/8"	8' 2-1/4"	39-1/4"	28' 2"
eco-ATC-2569-1g	1822	(4) 30	389,500	106,640	23,550	139,660	2313	315	(4) 5	3600	2280	(4) 12"	121,100	17' 10-7/8"	9' 8-5/8"	8' 2-1/4"	39-1/4"	28' 2"
eco-ATC-2585-1g	1834	(4) 25	358,800	122,600	27,540	156,460	2761	376	(4) 5	3600	2280	(4) 12"	137,900	18' 7-3/8"	10' 5-1/8"	8' 2-1/4"	47-3/4"	28' 2"
eco-ATC-2681-1g	1902	(4) 30	377,500	122,800	27,590	156,660	2761	376	(4) 5	3600	2280	(4) 12"	138,100	18' 7-3/8"	10' 5-1/8"	8' 2-1/4"	47-3/4"	28' 2"
eco-ATC-2722-1g	1931	(4) 40	422,300	107,280	23,710	140,300	2313	315	(4) 5	3600	2280	(4) 12"	121,740	17' 10-7/8"	9' 8-5/8"	8' 2-1/4"	39-1/4"	28' 2"
eco-ATC-2841-1g	2015	(4) 40	408,900	123,440	27,750	157,300	2761	376	(4) 5	3600	2280	(4) 12"	138,740	18' 7-3/8"	10' 5-1/8"	8' 2-1/4"	47-3/4"	28' 2"

* Tons at standard conditions: 96.3°F condensing, 20°F suction and 78°F W.B.

** Gallons shown is water in suspension in unit and piping. Allow for additional water in bottom of remote sump to cover pump suction and strainer during operation. (12" would normally be sufficient.)

† Heaviest section is the coil section. **Weights shown are for 1g seismic design.**

*** Refrigerant charge is shown for R-717. Multiply by 1.93 for R-22 and 1.98 for R-134a.

Dimensions are subject to change. Do not use for pre-fabrication. Quantity of coil connections subject to change based on refrigerant and design conditions.



Engineering Dimensions & Data

Models eco-ATC-2545-1g to 4086-1g

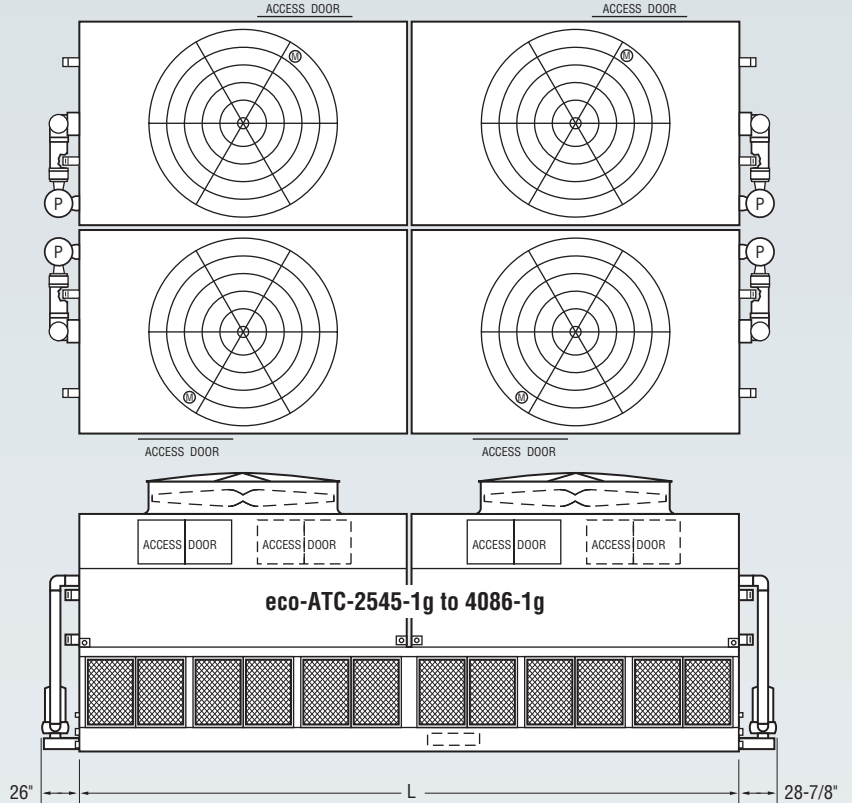
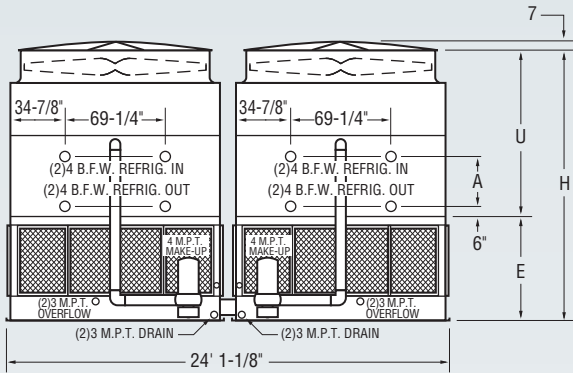

Table 19 Engineering Data

Model No.	R-717 Tons*	Fans		Weights†			Refrigerant Operating Charge lbs.***	Coil Volume ft ³	Spray Pump		Remote Pump			Dimensions				
		HP	CFM	Shipping	Heaviest Section†	Operating			HP	GPM	Gallons Req'd**	Conn. Size	Operating Weight	Height H	Upper U	Lower E	Coil A	Length L
eco-ATC-2545-1g	1805	(4) 20	446,500	97,800	20,380	137,840	1809	246	(4) 7-1/2	4800	2880	(4) 12"	114,060	16' 5-7/8"	8' 3-5/8"	8' 2-1/4"	22-1/4"	36' 2-1/2"
eco-ATC-2678-1g	1900	(4) 25	481,000	97,920	20,410	137,960	1809	246	(4) 7-1/2	4800	2880	(4) 12"	114,180	16' 5-7/8"	8' 3-5/8"	8' 2-1/4"	22-1/4"	36' 2-1/2"
eco-ATC-2798-1g	1985	(4) 30	511,100	98,120	20,460	138,160	1809	246	(4) 7-1/2	4800	2880	(4) 12"	114,380	16' 5-7/8"	8' 3-5/8"	8' 2-1/4"	22-1/4"	36' 2-1/2"
eco-ATC-2809-1g	1993	(4) 20	433,700	116,840	25,140	158,000	2386	325	(4) 7-1/2	4800	2880	(4) 12"	134,220	17' 2-3/8"	9' 1/8"	8' 2-1/4"	30-3/4"	36' 2-1/2"
eco-ATC-2953-1g	2095	(4) 20	420,200	135,240	29,740	177,520	2964	404	(4) 7-1/2	4800	2880	(4) 12"	153,740	17' 10-7/8"	9' 8-5/8"	8' 2-1/4"	39-1/4"	36' 2-1/2"
eco-ATC-2957-1g	2098	(4) 25	466,400	116,960	25,170	158,120	2386	325	(4) 7-1/2	4800	2880	(4) 12"	134,340	17' 2-3/8"	9' 1/8"	8' 2-1/4"	30-3/4"	36' 2-1/2"
eco-ATC-3089-1g	2191	(4) 30	496,500	117,160	25,220	158,320	2386	325	(4) 7-1/2	4800	2880	(4) 12"	134,540	17' 2-3/8"	9' 1/8"	8' 2-1/4"	30-3/4"	36' 2-1/2"
eco-ATC-3109-1g	2205	(4) 25	452,600	135,360	29,770	177,640	2964	404	(4) 7-1/2	4800	2880	(4) 12"	153,860	17' 10-7/8"	9' 8-5/8"	8' 2-1/4"	39-1/4"	36' 2-1/2"
eco-ATC-3249-1g	2305	(4) 30	481,000	135,560	29,820	177,840	2964	404	(4) 7-1/2	4800	2880	(4) 12"	154,060	17' 10-7/8"	9' 8-5/8"	8' 2-1/4"	39-1/4"	36' 2-1/2"
eco-ATC-3391-1g	2405	(4) 30	466,400	154,160	34,470	197,560	3542	483	(4) 7-1/2	4800	2880	(4) 12"	173,780	18' 7-3/8"	10' 5-1/8"	8' 2-1/4"	47-3/4"	36' 2-1/2"
eco-ATC-3447-1g	2445	(4) 40	522,300	136,200	29,980	178,480	2964	404	(4) 7-1/2	4800	2880	(4) 12"	154,700	17' 10-7/8"	9' 8-5/8"	8' 2-1/4"	39-1/4"	36' 2-1/2"
eco-ATC-3599-1g	2553	(4) 40	506,000	154,800	34,630	198,200	3542	483	(4) 7-1/2	4800	2880	(4) 12"	174,420	18' 7-3/8"	10' 5-1/8"	8' 2-1/4"	47-3/4"	36' 2-1/2"
eco-ATC-3766-1g	2671	(4) 50	538,700	154,840	34,640	198,240	3542	483	(4) 7-1/2	4800	2880	(4) 12"	174,460	18' 7-3/8"	10' 5-1/8"	8' 2-1/4"	47-3/4"	36' 2-1/2"
eco-ATC-2911-1g	2065	(4) 30	546,100	107,780	22,410	152,680	2004	273	(4) 10	5600	3200	(4) 14"	125,580	16' 5-7/8"	8' 3-5/8"	8' 2-1/4"	22-1/4"	40' 2-1/2"
eco-ATC-3095-1g	2196	(4) 25	498,600	128,540	27,600	174,680	2647	361	(4) 10	5600	3200	(4) 14"	147,580	17' 2-3/8"	9' 1/8"	8' 2-1/4"	30-3/4"	40' 2-1/2"
eco-ATC-3215-1g	2281	(4) 30	529,900	128,740	27,650	174,880	2647	361	(4) 10	5600	3200	(4) 14"	147,780	17' 2-3/8"	9' 1/8"	8' 2-1/4"	30-3/4"	40' 2-1/2"
eco-ATC-3381-1g	2398	(4) 30	513,700	149,220	32,770	196,560	3290	448	(4) 10	5600	3200	(4) 14"	169,460	17' 10-7/8"	9' 8-5/8"	8' 2-1/4"	39-1/4"	40' 2-1/2"
eco-ATC-3398-1g	2410	(4) 25	468,200	171,620	38,370	220,200	3932	536	(4) 10	5600	3200	(4) 14"	193,100	18' 7-3/8"	10' 5-1/8"	8' 2-1/4"	47-3/4"	40' 2-1/2"
eco-ATC-3425-1g	2430	(4) 40	578,400	129,380	27,810	175,520	2647	361	(4) 10	5600	3200	(4) 14"	148,420	17' 2-3/8"	9' 1/8"	8' 2-1/4"	30-3/4"	40' 2-1/2"
eco-ATC-3530-1g	2504	(4) 30	497,500	171,820	38,420	220,400	3932	536	(4) 10	5600	3200	(4) 14"	193,300	18' 7-3/8"	10' 5-1/8"	8' 2-1/4"	47-3/4"	40' 2-1/2"
eco-ATC-3603-1g	2556	(4) 40	561,300	149,860	32,930	197,200	3290	448	(4) 10	5600	3200	(4) 14"	170,100	17' 10-7/8"	9' 8-5/8"	8' 2-1/4"	39-1/4"	40' 2-1/2"
eco-ATC-3762-1g	2669	(4) 40	543,200	172,460	38,580	221,040	3932	536	(4) 10	5600	3200	(4) 14"	193,940	18' 7-3/8"	10' 5-1/8"	8' 2-1/4"	47-3/4"	40' 2-1/2"
eco-ATC-3770-1g	2674	(4) 50	597,400	149,900	32,940	197,240	3290	448	(4) 10	5600	3200	(4) 14"	170,140	17' 10-7/8"	9' 8-5/8"	8' 2-1/4"	39-1/4"	40' 2-1/2"
eco-ATC-3937-1g	2793	(4) 50	578,400	172,500	38,590	221,080	3932	536	(4) 10	5600	3200	(4) 14"	193,980	18' 7-3/8"	10' 5-1/8"	8' 2-1/4"	47-3/4"	40' 2-1/2"
eco-ATC-4086-1g	2898	(4) 60	608,900	173,300	38,790	221,880	3932	536	(4) 10	5600	3200	(4) 14"	194,780	18' 7-3/8"	10' 5-1/8"	8' 2-1/4"	47-3/4"	40' 2-1/2"

* Tons at standard conditions: 96.3°F condensing, 20°F suction and 78°F W.B.

** Gallons shown is water in suspension in unit and piping. Allow for additional water in bottom of remote sump to cover pump suction and strainer during operation. (12" would normally be sufficient.)

† Heaviest section is the coil section. **Weights shown are for 1g seismic design.**

*** Refrigerant charge is shown for R-717. Multiply by 1.93 for R-22 and 1.98 for R-134a.

Dimensions are subject to change. Do not use for pre-fabrication. Quantity of coil connections subject to change based on refrigerant and design conditions.

eco-ATC Steel Support

EVAPCO eco-ATC condensers are designed to be supported with structural "I" beams located under the outer flanges and running the entire length of the unit. Mounting holes, 3/4" in diameter are located in the bottom channels of the pan section to provide for bolting to the structural steel. (Refer to certified drawings from the factory for bolt hole locations.)

Beams should be level to within 1/8" in 6' before setting the unit in place. Do not level the unit by shimming between it and the "I" beams as this will not provide proper longitudinal support.

NOTE: Consult IBC 2006 for required steel support layout and structural design.

Plan Views

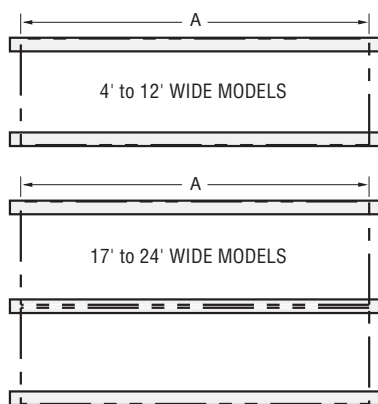

End Elevations

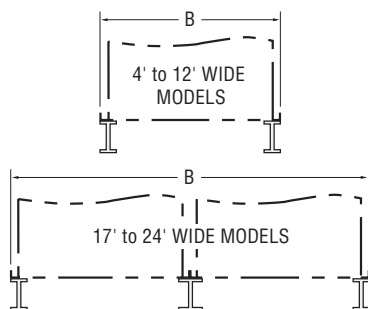

eco-ATC Steel Support		
8-1/2' Wide Models	A	B
eco-ATC-176-1g to 272-1g	8' 5-1/2"	7' 5-7/8"
226-1g to 334-1g	8' 11-1/2"	8' 5-1/2"
255-1g to 401-1g	10' 5-1/2"	8' 5-1/2"
360-1g to 439-1g	11' 11-3/4"	8' 5-1/2"
385-1g to 487-1g	13' 11-3/4"	8' 5-1/2"
477-1g to 668-1g	18'	8' 5-1/2"
501-1g to 797-1g	21'	8' 5-1/2"
657-1g to 876-1g	24' 2"	8' 5-1/2"
770-1g to 1010-1g	28' 2"	8' 5-1/2"
17' Wide Models	A	B
eco-ATC-658-1g to 877-1g	11' 11-3/4"	17' 4-1/8"
771-1g to 1011-1g	13' 11-3/4"	17' 4-1/8"
10' Wide Models	A	B
eco-ATC-280-1g to 503-1g	11' 11-3/4"	9' 9-3/4"
365-1g to 705-1g	18'	9' 9-3/4"
559-1g to 1005-1g	24' 2"	9' 9-3/4"
731-1g to 1411-1g	36' 2-1/2"	9' 9-3/4"
12' Wide Models	A	B
eco-ATC-433-1g to 644-1g	11' 11-3/4"	11' 10"
557-1g to 710-1g	13' 11-3/4"	11' 10"
363-1g to 942-1g	18'	11' 10"
775-1g to 1023-1g	20'	11' 10"
866-1g to 1288-1g	24' 2"	11' 10"
1176-1g to 1420-1g	28' 2"	11' 10"
1186-1g to 1883-1g	36' 2-1/2"	11' 10"
1607-1g to 2043-1g	40' 2-1/2"	11' 10"
24' Wide Models	A	B
eco-ATC-867-1g to 1289-1g	11' 11-3/4"	24' 1-1/8"
1177-1g to 1421-1g	13' 11-3/4"	24' 1-1/8"
1187-1g to 1884-1g	18'	24' 1-1/8"
1608-1g to 2044-1g	20'	24' 1-1/8"
1844-1g to 2572-1g	24' 2"	24' 1-1/8"
2353-1g to 2841-1g	28' 2"	24' 1-1/8"
2545-1g to 3766-1	36' 2-1/2"	24' 1-1/8"
2911-1g to 4086-1g	40' 2-1/2"	24' 1-1/8"



eco-ATC Optional Equipment

Electric Heaters

Electric immersion heaters are available factory installed in the basin of the condenser. They are sized to maintain a +40° F pan water temperature with the fans off and an ambient air temperature of 0°F, -20°F or -40°F. They are furnished with a thermostat to cycle the heater on when required and a low water protection device to prevent the heater elements from energizing unless they are completely submerged. All components are in weather proof enclosures for outdoor use. The heater power contactors and electric wiring are not included as standard.

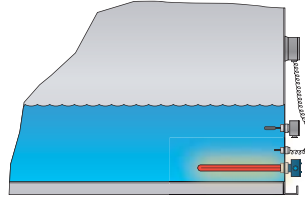

eco-ATC Heater Sizes (kW)			
Models	0°F	-20°F	-40°F
eco-ATC-176-1g to 272-1g	6	8	12
226-1g to 334-1g	7	10	15
255-1g to 401-1g	8	12	15
360-1g to 439-1g	(2) 4	(2) 7	(2) 9
385-1g to 487-1g	(2) 5	(2) 7	(2) 10
477-1g to 668-1g	(2) 6	(2) 9	(2) 12
501-1g to 797-1g	(2) 7	(2) 12	(2) 15
657-1g to 876-1g	(4) 4	(4) 7	(4) 9
770-1g to 1010-1g	(4) 5	(4) 7	(4) 10
eco-ATC-658-1g to 877-1g	(4) 4	(4) 7	(4) 9
771-1g to 1011-1g	(4) 5	(4) 7	(4) 10
eco-ATC-280-1g to 503-1g	(2) 5	(2) 8	(2) 10
365-1g to 705-1g	(2) 7	(2) 12	(2) 15
559-1g to 1005-1g	(4) 5	(4) 8	(4) 10
731-1g to 1411-1g	(4) 7	(4) 12	(4) 15
eco-ATC-433-1g to 644-1g	(2) 6	(2) 9	(2) 12
557-1g to 710-1g	(2) 7	(2) 10	(2) 15
363-1g to 942-1g	(2) 9	(2) 15	(2) 18
775-1g to 1023-1g	(2) 10	(2) 15	(3) 15
866-1g to 1288-1g	(4) 6	(4) 9	(4) 12
1176-1g to 1420-1g	(4) 7	(4) 10	(4) 15
1186-1g to 1883-1g	(4) 9	(4) 15	(4) 18
1607-1g to 2043-1g	(4) 10	(4) 15	(6) 15
eco-ATC-867-1g to 1289-1g	(4) 6	(4) 9	(4) 12
1177-1g to 1421-1g	(4) 7	(4) 10	(4) 15
1187-1g to 1884-1g	(4) 9	(4) 15	(4) 18
1608-1g to 2044-1g	(4) 10	(4) 15	(4) 20
1844-1g to 2572-1g	(4) 12	(4) 18	(6) 15
2353-1g to 2841-1g	(4) 15	(4) 20	(6) 18
2545-1g to 3766-1	(4) 18	(6) 18	(8) 18
2911-1g to 4086-1g	(4) 20	(6) 20	(8) 20



Pulse~Pure® is an environmentally sensitive non-chemical water treatment system for evaporative condensers. Developed by EVAPCO, Pulse~Pure offers an alternative to chemical water treatment programs. Utilizing pulse-power technology Pulse~Pure provides chemical-free treatment that is environmentally safe.

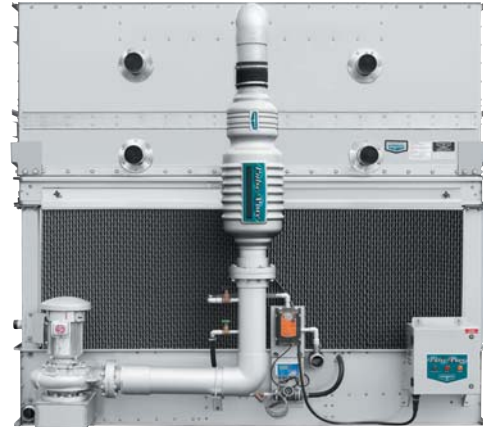

Self Supporting Service Platforms

Condensers are available with self-supporting service platforms that include access ladders which are designed for easy field installation. This option offers significant savings in comparison to field constructed, externally supported catwalks. The Evapco service platform option is located at each maintenance access door.



eco-ATC Condenser with Optional Service Platform and Motor Davit

Motor Davit

In the event that a fan motor should need to be replaced, a lightweight motor davit is available from which a chain fall can be mounted to easily lower the motor to the ground.

Electric Water Level Control

Evaporative condensers may be ordered with an electric water level control in lieu of the standard mechanical float and make-up assembly. This package provides accurate control of water levels and does not require field adjustment.



eco-ATC Optional Equipment

Two Speed Motors

Two speed fan motors can provide an excellent means of capacity control. In periods of lightened loads or reduced wet bulb temperatures, the fans can operate at low speed, which will provide about 60% of full speed capacity, yet consume only about 15% of the power compared with high speed. In addition to the energy savings, the sound levels of the units will be greatly reduced at low speed.

Sound Reduction Options

Super-Low Sound Fan

EVAPCO's Super Low Sound Fan utilizes an extremely wide chord blade design and is ideal for low energy, sound sensitive installations without sacrificing thermal performance. This revolutionary technology is one-piece molded, heavy duty fiberglass reinforced polyester hub and blade construction utilizing a forward swept blade design. The Super Low Sound Fan is capable of reducing the unit sound pressure levels 9 dB(A) to 15 dB(A) depending on specific unit selection and measurement location.

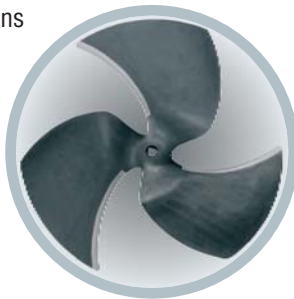

Water Silencer

The water silencer option, constructed of lightweight PVC sections, is located in the falling water area of the cold water basin. This option will reduce the overall sound levels 4 dB(A) to 7 dB(A), measured 5 ft. from the side or end of the unit, with no impact on unit thermal performance. This option will also reduce the overall sound levels 9 dB(A) to 12 dB(A) when operating the condenser with the fans off and water circulating.

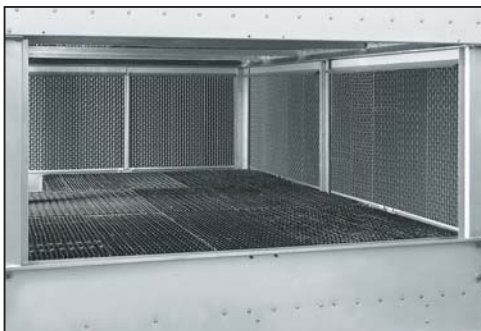

Stainless Steel Basin

eco-ATC condensers are available with an inexpensive all stainless steel basin section. This provides superior corrosion resistance over other materials of construction.

Remote Sump Configuration

For units operating in areas where temperatures may be very low, or where low temperatures may occur during periods when the unit is not operating, a sump located inside the building is the preferred means of ensuring that the basin water will not freeze. For these applications, the condenser will be supplied without the spray pump, suction strainers and all associated piping, but with an oversize bottom outlet.

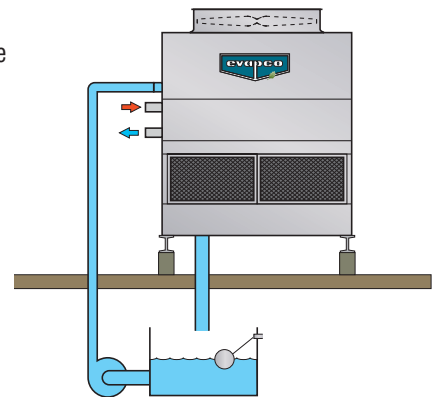

Multiple Circuit Coils

Condensers may be supplied with multiple circuit coils to match various system requirements such as split systems, or if a glycol or water circuit is desired for compressor head cooling.

Additional Options Available – Please contact your local EVAPCO Sales Representative or the EVAPCO factory for assistance.



eco-ATC Application

Design

EVAPCO units are heavy-duty construction and designed for long trouble-free operation. Proper equipment selection, installation and maintenance is, however, necessary to ensure good unit performance. Some of the major considerations in the application of a condenser are presented below. For additional information, contact the factory.

Structural Steel Support

The method of support for EVAPCO condensers is two structural "I" beams located under the outer flanges and running the entire length of the unit. Mounting holes 3/4" in diameter, are located in the bottom channels of the pan section to provide for bolting to the structural steel; refer to certified drawings from the factory for bolt hole locations.

Beams should be level to within 1/8" in 6' before setting the unit in place. Do not level the unit by shimming between it and the "I" beams as this will not provide proper longitudinal support.

NOTE: Consult IBC 2006 for required steel support layout and structural design.

Air Circulation

In reviewing the system design and unit location, it is important that proper air circulation be provided. The best location is on an unobstructed roof top or on ground level away from walls and other barriers. Care must be taken when locating condensers in wells or enclosures or next to high walls. The potential for recirculation of hot, moist discharge air back into the fan intake exists. Recirculation raises the wet bulb temperature of the entering air causing the condensing pressure to rise above the design. For these cases, a discharge hood or ductwork should be provided to raise the overall unit height even with the adjacent wall, thereby reducing the chance of recirculation. Good engineering practice dictates that the evaporative condenser's discharge air not be directed or located close to or in the vicinity of building air intakes. Engineering assistance is available from the factory to identify potential recirculation problems and recommend solutions.

For additional information regarding layout of evaporative condensers, see EVAPCO Bulletin entitled "*Equipment Layout*".

Piping

Condenser piping should be designed and installed in accordance with generally accepted engineering practice. All piping should be anchored by properly designed hangers and supports with allowance made for possible expansion and contraction. No external loads should be placed upon condenser connections, nor should any of the pipe supports be anchored to the unit framework. For additional information concerning refrigerant pipe sizing and layout, see EVAPCO Bulletin entitled "*Piping Evaporative Condensers*".

Maintaining the Recirculated Water System

The heat rejection in a condenser is accomplished by the evaporation of a portion of the recirculated spray water. As this water evaporates, it leaves behind all of its mineral content and impurities. Therefore, it is important to bleed-off an amount of water equal to that which is evaporated to prevent the build-up of these impurities. If this is not done, the mineral or the acidic nature of the water will continue to increase. This will ultimately result in heavy scaling or a corrosive condition.

Bleed-off

Each unit supplied with a pump mounted on the side is furnished with a clear bleed line for visual inspection and a valve which, when fully open, will bleed-off the proper amount of water. If the make-up water supplying the unit is relatively free of impurities, it may be possible to cut back the bleed, but the unit must be checked frequently to make sure scale is not forming. Make-up water pressure should be maintained between 20 and 50 psig.

Water Treatment

A proper water treatment program is an essential part of routine maintenance in order to help assure proper operation and longevity of the unit. To help prevent the formation of "white rust", the interior of the unit should be passivated during start-up and monitored periodically as part of the water treatment program. For more information about white rust, please request a copy of EVAPCO Engineering Bulletin 36. A qualified water treatment company should be contacted to design a water treatment protocol specifically based on applicable location, water quality and unit materials of construction.

If acid is used for treatment, it should be accurately metered and the concentration properly controlled. **The pH of the water should be maintained between 6.5 and 8.0. Units constructed of galvanized steel operating with circulating water having a pH of 8.3 or higher will require periodic passivation of the galvanized steel to prevent the formation of "white rust"**. Batch chemical feeding is not recommended because it does not afford the proper degree of control. If acid cleaning is required extreme caution must be exercised and only inhibited acids recommended for use with galvanized construction should be used.

NOTE: Operating the condenser below 6.0 pH for any period of time may cause the removal of the protective zinc coating on the galvanized steel components.

For more information see EVAPCO Bulletin entitled "*Maintenance Instructions*".

Control of Biological Contamination

Water quality should be checked regularly for biological contamination. If biological contamination is detected, a more aggressive water treatment and mechanical cleaning program should be undertaken. The water treatment program should be performed in conjunction with a qualified water treatment company. It is important that all internal surfaces be kept clean of accumulated dirt and sludge. In addition, the drift eliminators should be maintained in good operating condition.

Solutions for Sound Sensitive Applications

The eco-ATC product line is now available with four (4) equipment options to reduce the overall sound generated from the side or top of the unit. Each option provides various levels of sound reduction and can be used in combination to provide the lowest sound level. Consult EVAPCO's *evapSelect™* selection program for unit sound levels. If a detailed analysis or full octave band data sheet is required for your application, please consult your EVAPCO Sales Representative.

NOTE: These low sound options may impact the overall installed dimensions and weight of the unit.

eco-ATC Mechanical Specifications

Furnish and install, as shown on the plans, an EVAPCO model _____ induced draft, counterflow evaporative condenser with a condensing capacity of _____ MBH total heat of rejection when operating with _____ refrigerant at _____ °F condensing temperature with a _____ °F design wet bulb temperature and a dry bulb switchover temperature of _____ °F.

IBC 2006 Compliance

The condenser shall be designed and constructed to meet the International Building Code (IBC 2006) specifications for installed components per ASCE 7-05. The manufacturer shall provide a certificate of compliance to demonstrate that the equipment/unit has been independently tested and certified in accordance with the IBC program.

Basin and Casing

The basin and casing shall be constructed of G-235 hot-dip galvanized steel for long life and durability. Standard basin accessories shall include overflow, drain, type 304 stainless steel strainers, and brass make-up valve with plastic float.

Models eco-ATC-176-1g to 1011-1g

Fan Motor

_____ horsepower totally enclosed fan cooled motors with 1.15 service factor shall be furnished suitable for outdoor service on _____ volts, _____ hertz, and _____ phase. Motor(s) shall be mounted on an adjustable base which is accessible from the outside of the unit for service. A swing away protective cover shall shield the motor and sheave from the weather.

Drive

The fan drive shall be multigroove, solid back V-belt type with taper lock bushings designed for 150% of the motor nameplate horsepower. The belt material shall be neoprene reinforced with polyester cord and specifically designed for evaporative condenser service. Fan sheave shall be aluminum alloy construction. The fans and the fan sheaves shall be mounted on the shaft with a specially coated bushing to provide maximum corrosion protection. Belt adjustment shall be accomplished from the exterior of the unit. Bearing lube lines shall be extended to the exterior of the unit for easy maintenance.

Models eco-ATC-280-1g to 4086-1g

Fan Motor

_____ horsepower totally enclosed air over ball bearing fan motor(s), with 1.15 service factor shall be furnished suitable for service on _____ volts, _____ hertz, and _____ phase. Motor(s) shall be mounted on an adjustable base which allows the motor to swing to the outside of the unit for servicing.

Drive

The fan drive shall be a multigroove, solid back V-belt type with taper lock bushings designed for 150% of the motor nameplate horsepower. The belt material shall be neoprene reinforced with polyester cord and specifically designed for evaporative condenser service. Fan and motor sheaves shall be aluminum alloy construction. The fans and fan sheaves shall be mounted on the shaft with a specially coated bushing to provide maximum corrosion protection. Belt adjustment shall be accomplished from the exterior of the unit. Bearing lube lines shall be extended to the exterior of the unit for easy maintenance.

Axial Propeller Fans

Fans shall be heavy duty axial propeller type statically balanced. The fans shall be constructed of aluminum alloy or fiberglass reinforced polypropylene blades, installed in a closely fitted cowl with venturi air inlet. Fan screens shall be galvanized steel mesh and frame, bolted to the fan cowl.

Fan Shaft Bearings

Fan shaft bearings shall be heavy duty self-aligning ball type with grease fittings extended to the outside of the unit. Bearings shall be designed for a minimum L-10 life of 75,000 hours.

Water Recirculation Pump

The pump(s) shall be a close-coupled, centrifugal type with mechanical seal, installed vertically at the factory to allow free drainage on shut down. _____ horsepower totally enclosed motor(s) shall be furnished suitable for outdoor service on _____ volts, _____ hertz, and _____ phase.

Heat Transfer Coil

Condensing coil(s) shall be all prime surface steel, encased in a steel framework and hot-dip galvanized after fabrication as a complete assembly. The coil(s) shall be designed with sloping tubes for free drainage of liquid refrigerant and shall be pneumatically tested at 400 psig, under water.

Water Distribution System

The system shall provide a water flow rate of 6 GPM over each square foot of unit face area to ensure proper flooding of the coil. The spray header shall be constructed of schedule 40 polyvinyl chloride pipe for corrosion resistance. All spray branches shall be removable for cleaning. Heavy-duty molded nylon ZM spray nozzles with large 1-5/16" diameter opening and internal sludge ring to eliminate clogging. Nozzles shall be threaded into spray header to provide easy removal for maintenance.

Eliminators

The eliminators shall be constructed entirely of inert polyvinyl chloride (PVC) in easily handled sections. The eliminator design shall incorporate three changes in air direction to assure complete removal of all entrained moisture from the discharge air stream. Maximum drift rate shall be less than 0.001% of the circulating water rate.

Louvers

The louvers shall be constructed from polyvinyl chloride (PVC). The louvers shall be mounted in easily removable sections for access to the pan for maintenance. The louvers shall have a minimum of two changes in air direction to prevent splashout and block direct sunlight.

Finish

All basin and casing materials shall be constructed of G-235 heavy gauge mill hot-dip galvanized steel. During fabrication, all panel edges shall be coated with a 95% pure zinc-rich compound for superior protection against corrosion.



EVAPCO PRODUCTS ARE MANUFACTURED WORLDWIDE.



- World Headquarters/ Research and Development Center
- EVAPCO Facilities

EVAPCO, Inc. — World Headquarters & Research/Development Center

EVAPCO, Inc. • P.O. Box 1300 • Westminster, MD 21158 USA
PHONE: 410-756-2600 • FAX: 410-756-6450 • E-MAIL: marketing@evapco.com

EVAPCO North America

EVAPCO, Inc.
World Headquarters
P.O. Box 1300
Westminster, MD 21158 USA
Phone: 410-756-2600
Fax: 410-756-6450
E-mail: marketing@evapco.com

EVAPCO East
5151 Allendale Lane
Taneytown, MD 21787 USA
Phone: 410-756-2600
Fax: 410-756-6450
E-mail: marketing@evapco.com

EVAPCO Midwest
1723 York Road
Greenup, IL 62428 USA
Phone: 217-923-3431
Fax: 217-923-3300
E-mail: evapcomw@evapcomw.com

EVAPCO West
1900 West Almond Avenue
Madera, CA 93637 USA
Phone: 559-673-2207
Fax: 559-673-2378
E-mail: contact@evapcowest.com

EVAPCO Iowa
925 Quality Drive
Lake View, IA 51450 USA
Phone: 712-657-3223
Fax: 712-657-3226

EVAPCO Iowa Sales & Engineering
1234 Brady Boulevard
Owatonna, MN 55060 USA
Phone: 507-446-8005
Fax: 507-446-8239
E-mail: evapcomn@evapcomn.com

Refrigeration Valves & Systems Corporation
A wholly owned subsidiary of EVAPCO, Inc.
1520 Crosswind Dr.
Bryan, TX 77808 USA
Phone: 979-778-0095
Fax: 979-778-0030
E-mail: rvs@rvscorp.com

McCormack Coil Company, Inc.
A wholly owned subsidiary of EVAPCO, Inc.
P.O. Box 1727
6333 S.W. Lakeview Boulevard
Lake Oswego, OR 97035 USA
Phone: 503-639-2137
Fax: 503-639-1800
E-mail: mail@mmcoil.com

EvapTech, Inc.
A wholly owned subsidiary of EVAPCO, Inc.
8331 Nieman Road
Lenexa, KS 66214 USA
Phone: 913-322-5165
Fax: 913-322-5166
E-mail: marketing@evaptech.com

Tower Components, Inc.
A wholly owned subsidiary of EVAPCO, Inc.
5960 US HWY 64E
Ramseur, NC 27316
Phone: 336-824-2102
Fax: 336-824-2190
E-mail: mail@towercomponentsinc.com

EVAPCO Newton
701 East Jourdan Street
Newton, IL 62448 USA
Phone: 618-783-3433
Fax: 618-783-3499
E-mail: evapcomw@evapcomw.com

EVAPCO Europe

EVAPCO Europe, N.V.
European Headquarters
Industrieterrein Oost 4010
3700 Tongeren, Belgium
Phone: (32) 12-395029
Fax: (32) 12-238527
E-mail: evapco.europe@evapco.be

EVAPCO Europe, S.r.l.
Via Ciro Menotti 10
I-20017 Passirana di Rho
Milan, Italy
Phone: (39) 02-939-9041
Fax: (39) 02-935-00840
E-mail: evapcoeuropa@evapco.it

EVAPCO Europe, S.r.l.
Via Dosso 2
23020 Piateda Sondrio, Italy

EVAPCO Europe, GmbH
Bovert 22
D-40670 Meerbusch, Germany
Phone: (49) 2159-69560
Fax: (49) 2159-695611
E-mail: info@evapco.de

Flex coil a/s
A wholly owned subsidiary of EVAPCO, Inc.
Knøsgårdvej 115
DK-9440 Aabybro Denmark
Phone: (45) 9824 4999
Fax: (45) 9824 4990
E-mail: info@flexcoil.dk

EVAPCO S.A. (Pty.) Ltd.
A licensed manufacturer of EVAPCO, Inc.
18 Quality Road
Isando 1600
Republic of South Africa
Phone: (27) 11-392-6630
Fax: (27) 11-392-6615
E-mail: evapco@evapco.co.za

Evap Egypt Engineering Industries Co.
A licensed manufacturer of EVAPCO, Inc.
5 El Nasr Road
Nasr City, Cairo, Egypt
Phone: 2 02 24022866 / 2 02 24044997
Fax: 2 02 24044667 / 2 02 24044668
E-mail: Primacool@link.net / Shady@primacool.net

EVAPCO Asia/Pacific

EVAPCO Asia/Pacific Headquarters
1159 Luoning Rd. Baoshan Industrial Zone
Shanghai, P. R. China, Postal Code: 200949
Phone: (86) 21-6687-7786
Fax: (86) 21-6687-7008
E-mail: marketing@evapcochina.com

Evapco (Shanghai) Refrigeration Equipment Co., Ltd.
1159 Luoning Rd., Baoshan Industrial Zone
Shanghai, P.R. China, Postal Code: 200949
Phone: (86) 21-6687-7786
Fax: (86) 21-6687-7008
E-mail: marketing@evapcochina.com

Beijing EVAPCO Refrigeration Equipment Co., Ltd.
Yan Qi Industrial Development District
Huai Rou County
Beijing, P.R. China, Postal Code: 101407
Phone: (86) 10 6166-7238
Fax: (86) 10 6166-7395
E-mail: evapcobj@evapcochina.com

Evapco Australia (Pty.) Ltd.
34-42 Melbourne Road
P.O. Box 436
Riverstone, N.S.W. Australia 2765
Phone: (61) 2 9627-3322
Fax: (61) 2 9627-1715
E-mail: sales@evapco.com.au

EvapTech Asia Pacific Sdn. Bhd
A wholly owned subsidiary of EvapTech, Inc.
101 Business Park, 2/F Unit 20
Persiaran Puchong Jaya Selatan
Bandar Puchong Jaya,
47170 Puchong, Selangor, Malaysia
Phone: (60-3) 8070 7255
Fax: (60-3) 8070 5731
E-mail: marketing-ap@evaptech.com

EVAPCO...SPECIALISTS IN HEAT TRANSFER PRODUCTS AND SERVICES.



Mixed Sources
Product group from well-managed forests, controlled sources and recycled wood or fiber
www.fsc.org Cert no. BV-COC-080211
© 1996 Forest Stewardship Council

