

# **ANEXO II-I**

## **LISTA DE SÍMBOLOS**

Properties of symbol table

Name: Symbols  
 Comment:  
 Created on: 04.07.2011 18:25:44  
 Last modified on: 21.09.2011 12:17:02  
 Last filter criterion: Alle Symbole  
 Number of symbols: 68/ 68  
 Last Sorting: Address Ascending

Symbol	Address	Data type	Comment
DB DADOS	DB 1	DB 1	Guarda o registo dos utilizadores e dos ciclos de utilizacao
FC MOTOR CONTROL	FC 1	FC 1	Controla o movimento dos motores
FC COMPARE	FC 2	FC 2	Verifica se a posicao esta vazia e devolve a sua contagem de ciclos
FC SEARCH EMPTY	FC 3	FC 3	Procura uma UA vazia
FC SEARCH ID	FC 4	FC 4	Procura a UA associada ao ID
FC GO POSITION	FC 5	FC 5	Funcao que cordena o movimento do MA para a ZER
FC GO HOME	FC 6	FC 6	Funcao que cordena o movimento do robo para a posicao HOME
FC CHECK	FC 7	FC 7	Verifica o conteudo da UA
FC REGISTER	FC 8	FC 8	Regista a operacao de check-in/check-out
FC OPERATION	FC 9	FC 9	Cordena a operacao de checkin checkout
D TOD DT	FC 13	FC 13	Date and TOD to DT
DT DATE	FC 16	FC 16	DT to DATE
DT TOD	FC 18	FC 18	DT to TOD
SB DT DT	FC 34	FC 34	Subtract DT - DT
TIM S5TI	FC 40	FC 40	IEC Time to S5 Time
X1	I 124.0	BOOL	
X2	I 124.1	BOOL	
X3	I 124.2	BOOL	
X4	I 124.3	BOOL	
X5	I 124.4	BOOL	
X6	I 124.5	BOOL	
X0	I 124.6	BOOL	
UA LOCK STATE	I 124.7	BOOL	Estado do bloqueio da UA
UA CHECK OK	I 125.0	BOOL	Verificacao da UA - Conteudo OK
DOOR CLOSED	I 125.1	BOOL	Portas automaticas - Estado Fechadas
UA CHECK FAIL	I 125.2	BOOL	Verificacao da UA - Conteudo INVALIDO
Z0	I 125.3	BOOL	
Z1	I 125.4	BOOL	
Z RECEPTION	I 125.5	BOOL	Z na zona de recepção e na zona de pesagem
Y1	I 125.6	BOOL	
Y2	I 125.7	BOOL	
USER OPERATION	I 126.0	BOOL	Comando Utilizador operacao de entrega/recolha
USER DOORS	I 126.1	BOOL	Comanda Utilizador fecho das portas
Y01	I 126.2	BOOL	Posicao de transporte 1
Y02	I 126.3	BOOL	Posicao de transporte 2
M1	M 1.0	BOOL	
M2	M 1.1	BOOL	
M3	M 1.2	BOOL	
M4	M 1.3	BOOL	
M5	M 1.4	BOOL	
M6	M 1.5	BOOL	
M7	M 1.6	BOOL	
M8	M 1.7	BOOL	
M START	M 2.0	BOOL	
M10	M 2.3	BOOL	
M11	M 2.4	BOOL	
OP CHECKIN	M 50.5	BOOL	
OP CHECKOUT	M 50.6	BOOL	
COM TEST	M 50.7	BOOL	Teste da comunicação com o display
M USERID	MW 50	WORD	User ID do leitor de cartoes
M TOTAL TIME	MW 51	WORD	Totaliza o tempo de uso do sistema
Main Program	OB 1	OB 1	

SIMATIC ...or\CPU 314IFM-CPU\Parque Bicicletas\Symbols 09/21/2011 16:31:35

Symbol	Address	Data type	Comment
Complete Restart	OB 100	OB 100	
UA WEIGHT	PIW 128	WORD	Leitura do peso da UA
DOOR OPEN CMD	Q 124.0	BOOL	Comando de Abertura das Portas
SYSTEM FULL ALARM	Q 124.4	BOOL	Lotacao Esgotada
UA_CHK_EMPTY CMD	Q 124.5	BOOL	Comanda a verificacao para detectar se a UA esta vazia
UA CONTENT ALARM	Q 124.6	BOOL	Alarme de conteudo da UA invalido
OPERATION DONE	Q 124.7	BOOL	Operacao terminada com sucesso
MX NORMAL	Q 125.0	BOOL	Motor X - Sentido Normal
MX REVERSE	Q 125.1	BOOL	Motor X - Sentido Reverso
MY NORMAL	Q 125.2	BOOL	Motor Y - Sentido Normal
MY REVERSE	Q 125.3	BOOL	Motor Y - Sentido Reverso
MZ NORMAL	Q 125.4	BOOL	Motor Z - Sentido Normal
MZ REVERSE	Q 125.5	BOOL	Motor Z - Sentido Reverso
UA_CHK_CONTENT_CMD	Q 125.6	BOOL	Comanda a verificacao do interior da UA
UA LOCK CMD	Q 125.7	BOOL	Bloqueia a UA na plataforma do elevador
READ_CLK	SFC 1	SFC 1	Read System Clock



## **ANEXO II-II**

### **OB1 “MAIN PROGRAM”**

**OB1 - <offline>**

"Main Program"  
 Name: Family:  
 Author: Version: 0.1  
 Block version: 2  
 Time stampCode: 21-09-2011 14:37:45  
 Interface: 21-09-2011 10:13:11  
 Lengths (block/logic/data): 00688 00524 00034

Address	Declaration	Name	Type	Initial value	Comment
0.0	temp	OB1_EV_CLASS	BYTE		Bits 0-3 = 1 (Coming event), Bits 4-7 = 1 (Event class 1)
1.0	temp	OB1_SCAN_1	BYTE		1 (Cold restart scan 1 of OB 1), 3 (Scan 2-n of OB 1)
2.0	temp	OB1_PRIORITY	BYTE		Priority of OB Execution
3.0	temp	OB1_OB_NUMBER	BYTE		1 (Organisation block 1, OB1)
4.0	temp	OB1_RESERVED_1	BYTE		Reserved for system
5.0	temp	OB1_RESERVED_2	BYTE		Reserved for system
6.0	temp	OB1_PREV_CYCLE	INT		Cycle time of previous OB1 scan (milliseconds)
8.0	temp	OB1_MIN_CYCLE	INT		Minimum cycle time of OB1 (milliseconds)
10.0	temp	OB1_MAX_CYCLE	INT		Maximum cycle time of OB1 (milliseconds)
12.0	temp	OB1_DATE_TIME	DATE AND TIME		Date and time OB1 started
20.0	temp	USER_ID	INT		Memoriza o ID do utilizador actual
22.0	temp	UA_SELECTED	INT		Memoriza a UA seleccionada
24.0	temp	M_USER_NOT_EXIST	BOOL		
26.0	temp	M_TIMERTEMP	TIME		v temp
30.0	temp	M_END	BOOL		
30.1	temp	M_SEARCH_ID	BOOL		
30.2	temp	M_SEARCH_EMPTY	BOOL		
30.3	temp	M_SYSTEM_FULL	BOOL		
30.4	temp	M1	BOOL		
30.5	temp	RESET	BOOL		

Block: OB1 "Main Program Sweep (Cycle)"

Network: 1 START

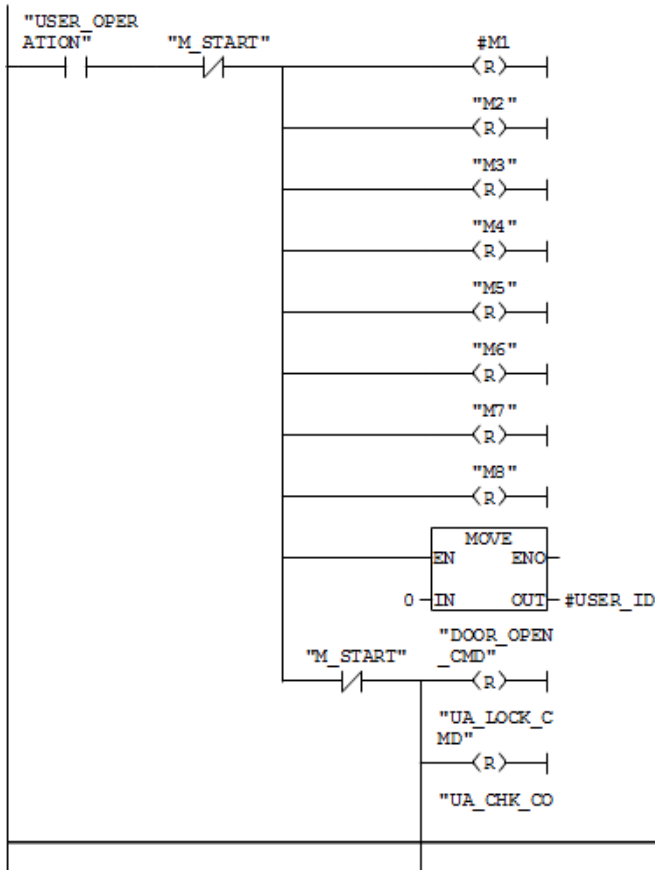

SIMATIC ...trolador\CPU 314IFM-CPU\...\NOB1 - <offline> 09/21/2011 16:26:38

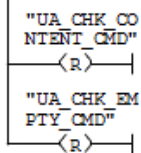

Symbol information  
 I126.0 USER OPERATION Comando Utilizador operacao de entrega/recolha  
 M2.0 M\_START  
 M1.1 M2  
 M1.2 M3  
 M1.3 M4  
 M1.4 M5  
 M1.5 M6  
 M1.6 M7  
 M1.7 M8  
 Q124.0 DOOR\_OPEN\_CMD Comando de Abertura das Portas  
 Q125.7 UA\_LOCK\_CMD Bloqueia a UA na plataforma do elevador  
 Q125.6 UA\_CHK\_CONTENT\_CMD Comanda a verificacao do interior da UA  
 Q124.5 UA\_CHK\_EMPTY\_CMD Comanda a verificacao para detectar se a UA esta vazia

Network: 2 RESET

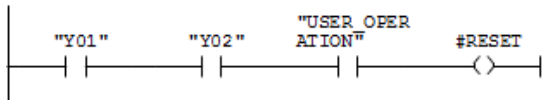

Symbol information  
 I126.2 Y01 Posicao de transporte 1  
 I126.3 Y02 Posicao de transporte 2  
 I126.0 USER\_OPERATION Comando Utilizador operacao de entrega/recolha

Network: 3 Controla a variavel de processo M\_START  
 Ao serem pressionados simultaneamente os contactos Y01 e Y02 é feito um reset a variavel M\_START

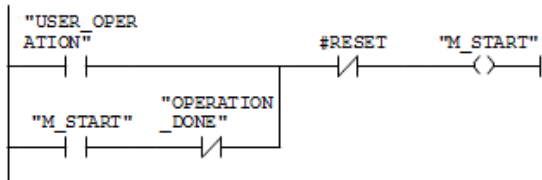

Symbol information  
 I126.0 USER\_OPERATION Comando Utilizador operacao de entrega/recolha  
 M2.0 M\_START  
 Q124.7 OPERATION\_DONE Operacao terminada com sucesso

Network: 4 Inicia o processo

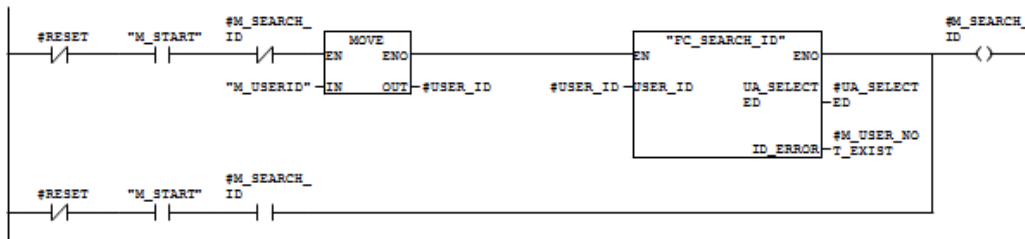

Symbol information

M2.0 M\_START  
 MW50 M\_USERID User ID do leitor de cartões  
 FC4 FC\_SEARCH\_ID Procura a UA associada ao ID

Network: 5

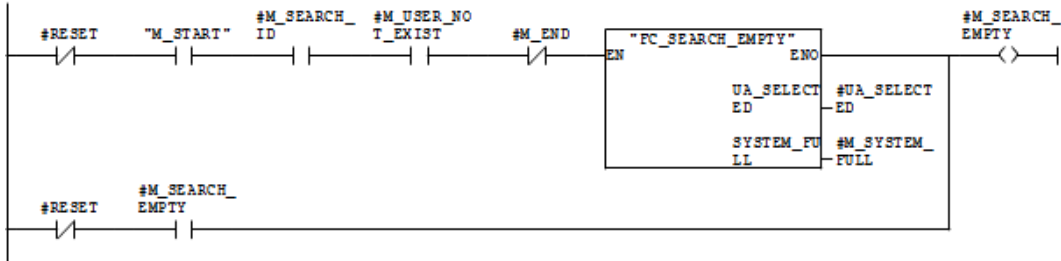

Symbol information

M2.0 M\_START  
 FC3 FC\_SEARCH\_EMPTY Procura uma UA vazia

Network: 6

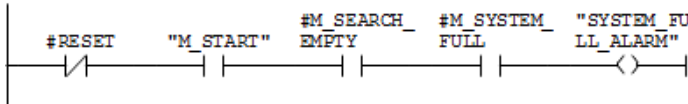

Symbol information

M2.0 M\_START  
 Q124.4 SYSTEM\_FULL\_ALARM Lotacao Esgotada

Network: 7

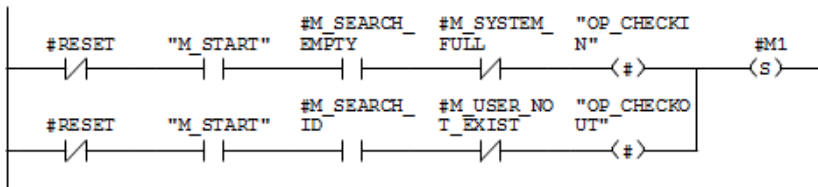

Symbol information

M2.0 M\_START  
 M50.5 OP\_CHECKIN  
 M50.6 OP\_CHECKOUT

Network: 8

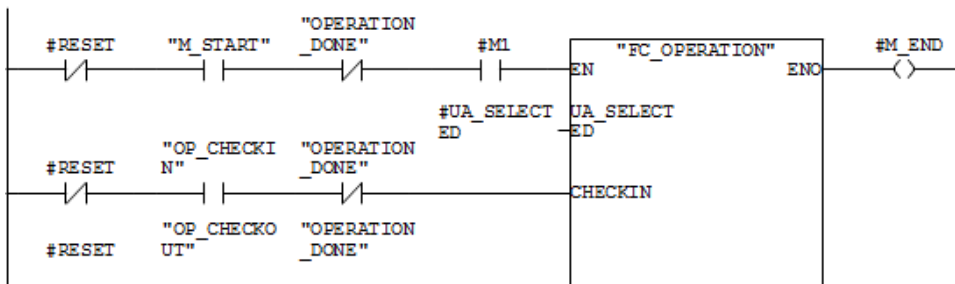

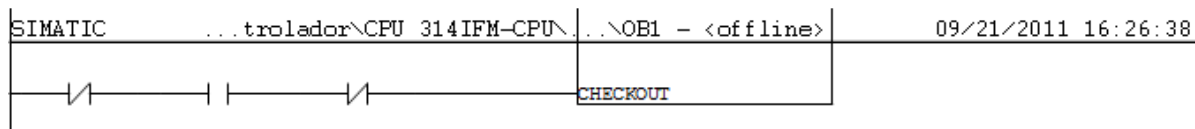

Symbol information

M2.0 M\_START  
 Q124.7 OPERATION\_DONE Operacao terminada com sucesso  
 M50.5 OP\_CHECKIN  
 M50.6 OP\_CHECKOUT  
 FC9 FC\_OPERATION Cordena a operacao de checkin checkout

Network: 9 END

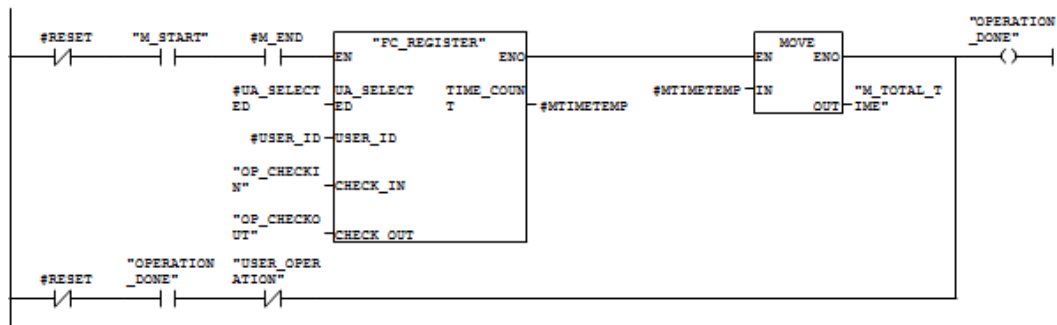

Symbol information

M2.0 M\_START  
 FC8 FC\_REGISTER Regista a operacao de check-in/check-out  
 M50.5 OP\_CHECKIN  
 M50.6 OP\_CHECKOUT  
 MW51 M\_TOTAL TIME Totaliza o tempo de uso do sistema  
 Q124.7 OPERATION\_DONE Operacao terminada com sucesso  
 I126.0 USER\_OPERAÇÃO Comando Utilizador operacao de entrega/recolha



## **ANEXO II-III**

### **FC1 “FC\_MOTOR\_CONTROL”**

**FC1 - <offline>**

"FC MOTOR\_CONTROL"      Controla o movimento dos motores  
 Name:                      Family:  
 Author: PG                      Version: 0.1  
                                     Block version: 2  
 Time stampCode:              21-09-2011 10:01:14  
                                     Interface:      06-09-2011 15:27:33  
 Lengths (block/logic/data): 00262 00138 00002

Address	Declaration	Name	Type	Initial value	Comment
0.0	in	X	BOOL		Sensor de X
0.1	in	Y	BOOL		Sensor de Y
0.2	in	Z	BOOL		Sensor de Z
0.3	in	Y0	BOOL		Posicao do Y0
0.4	in	START	BOOL		START
2.0	out	MX	BOOL		Controlo Motor X
2.1	out	MY	BOOL		Controlo Motor Y
2.2	out	MZ	BOOL		Controlo Motor Z
	in_out				
0.0	temp	M1	BOOL		Memoria temporaria

Block: FC1 Controlo dos motores

Network: 1      Controla o motor x

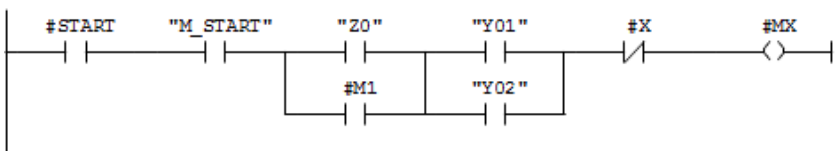

Symbol information  
 M2.0              M\_START  
 I125.3            Z0  
 I126.2            Y01              Posicao de transporte 1  
 I126.3            Y02              Posicao de transporte 2

Network: 2      Activa a memoria M1 ao passar por X1

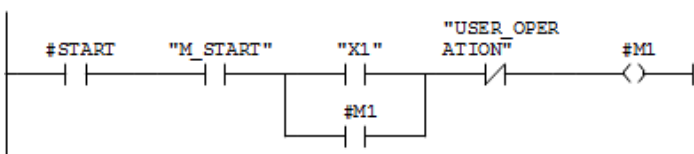

Symbol information  
 M2.0              M\_START  
 I124.0            X1  
 I126.0            USER\_OPERATION      Comando Utilizador operacao de entrega/recolha

Network: 3      Controla o motor Z

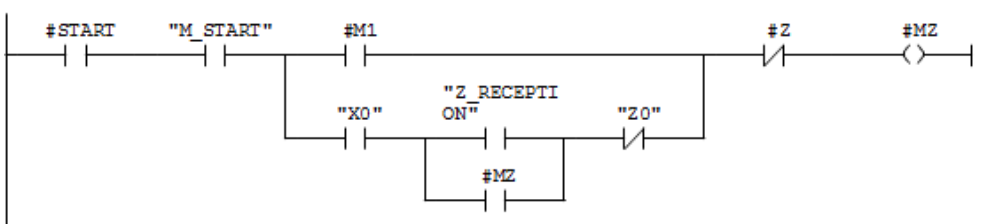

SIMATIC ... trolador\CPU 314IFM-CPU\...\FC1 - <offline> 09/21/2011 16:28:09

||

Symbol information

M2.0 M\_START  
 I124.6 X̄  
 I125.5 Z\_RECEPTION Z na zona de recepção e na zona de pesagem  
 I125.3 Z̄

Network: 4 Controla o motor Y

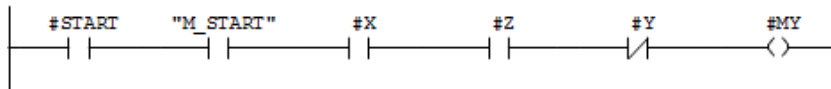

Symbol information

M2.0 M\_START

Network: 5 Fim da funcao

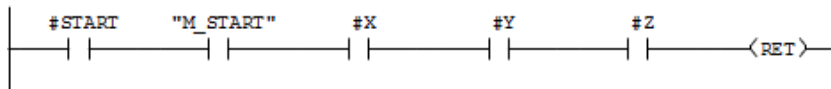

Symbol information

M2.0 M\_START



# **ANEXO II-IV**

## **FC2 “FC\_COMPARE”**

SIMATIC ...trolador\CPU 314IFM-CPU...\FC2 - <offline> 09/21/2011 16:28:15

**FC2 - <offline>**

"FC\_COMPARE" Verifica se a posicao esta vazia e devolve a sua contagem de ciclos  
 Name: Family:  
 Author: Version: 0.1  
 Block version: 2  
 Time stampCode: 21-09-2011 12:22:30  
 Interface: 04-07-2011 14:20:20  
 Lengths (block/logic/data): 00236 00124 00002

Address	Declaration	Name	Type	Initial value	Comment
0.0	in	UA_ID	INT		Variavel inteira da posicao
2.0	in	UA_CICLES	INT		Numero de ciclos da posicao
4.0	in	UA_INDEX	INT		Indice da posicao
6.0	out	UA_SELECTED	INT		Ultima posicao disponivel
8.0	in_out	C_TEMP	INT		
0.0	temp	MO	BOOL		Memoria temporaria

Block: FC2 Verifica disponibilidade da posicao

Network: 1 Caso POS\_ID=0 e C\_TEMP>UA\_CICLES

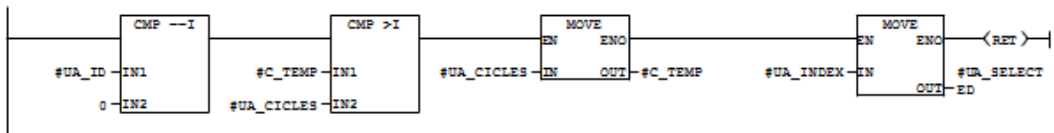

Network: 2 Caso POS\_ID=0 e C\_TEMP<=UA\_CICLES

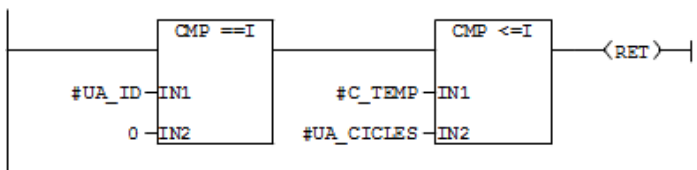

Network: 3 Caso POS\_ID<>0

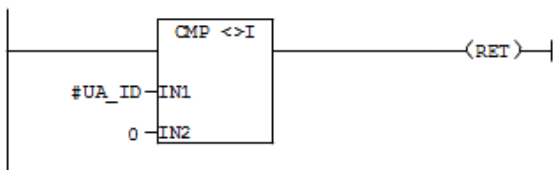

## **ANEXO II-V**

### **FC3 “FC\_SEARCH\_EMPTY”**

**FC3 - <offline>**

"FC\_SEARCH\_EMPTY" Procura uma UA vazia  
 Name: Family:  
 Author: Version: 0.1  
 Block version: 2  
 Time stampCode: 21-09-2011 12:29:54  
 Interface: 29-07-2011 12:03:45  
 Lengths (block/logic/data): 01954 01744 00012

Address	Declaration	Name	Type	Initial value	Comment
	in				
0.0	out	UA_SELECTED	INT		Variavel que devolve o index da posicao que foi seleccionada
2.0	out	SYSTEM_FULL	BOOL		Lotacao Esgotada
	in out				
0.0	temp	CICLES_TEMP	INT		Variavel temporaria com o valor mais baixo da contagem de ciclos
2.0	temp	SELECTED	INT		Variavel temporaria com a posicao ultima posicao seleccionada
4.0	temp	M1	BOOL		Memoria temporaria

Block: FC3 Procura uma UA vazia e com o n ciclos de utilizacao mais baixo

Network: 1 Inicializa as variaveis

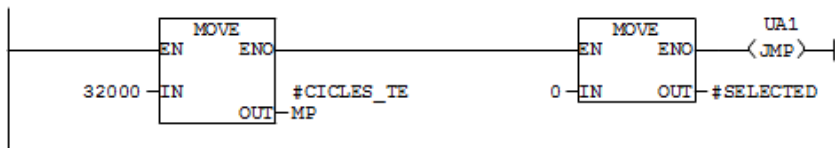

Network: 2 Abre a DB1



Symbol information  
 DB1 DB\_DADOS Guarda o registo dos utilizadores e dos ciclos de utilizacao

Network: 3 UA1

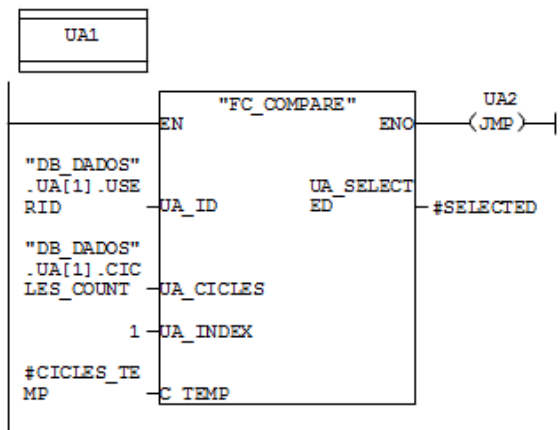

Symbol information

Symbol information

FC2 FC\_COMPARE Verifica se a posicao esta vazia e devolve a sua contagem de ciclos  
 DB1.DBW2 "DB\_DADOS".UA[1].USERID Identificacao do utilizador registado na UA  
 DB1.DBW4 "DB\_DADOS".UA[1].CICLES\_COUNT Registo do numero de ciclos da UA

Network: 4 UA2

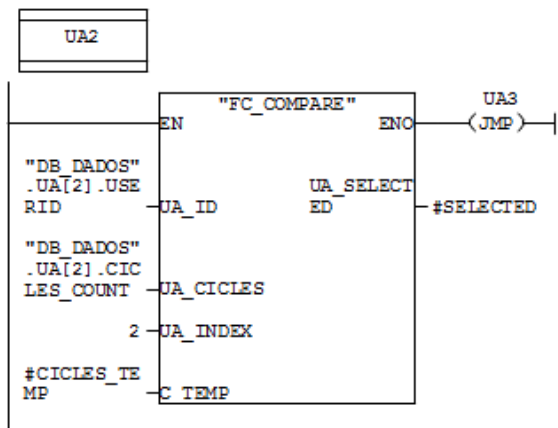

Symbol information

FC2 FC\_COMPARE Verifica se a posicao esta vazia e devolve a sua contagem de ciclos  
 DB1.DBW12 "DB\_DADOS".UA[2].USERID Identificacao do utilizador registado na UA  
 DB1.DBW14 "DB\_DADOS".UA[2].CICLES\_COUNT Registo do numero de ciclos da UA

Network: 5 UA2

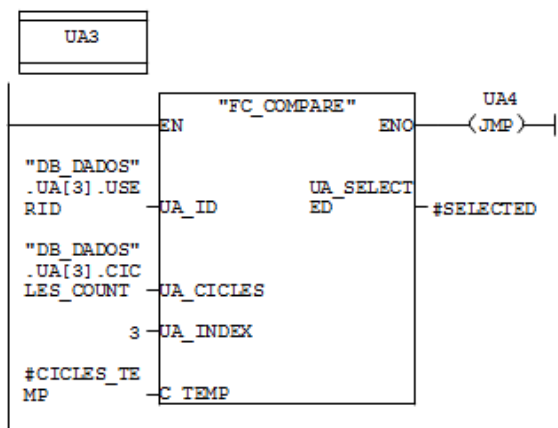

Symbol information

FC2 FC\_COMPARE Verifica se a posicao esta vazia e devolve a sua contagem de ciclos  
 DB1.DBW22 "DB\_DADOS".UA[3].USERID Identificacao do utilizador registado na UA  
 DB1.DBW24 "DB\_DADOS".UA[3].CICLES\_COUNT Registo do numero de ciclos da UA

Network: 6 UA2

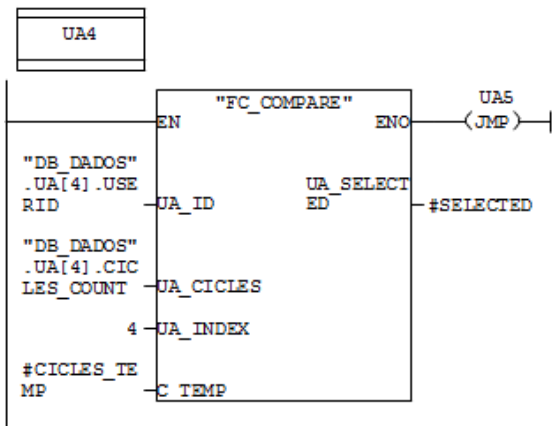

Symbol information  
 FC2 FC\_COMPARE Verifica se a posicao esta vazia e devolve a sua contagem de ciclos  
 DB1.DBW32 "DB\_DADOS".UA[4].USERID Identificacao do utilizador registado na UA  
 DB1.DBW34 "DB\_DADOS".UA[4].CICLES\_COUNT Registro do numero de ciclos da UA

Network: 7 UA5

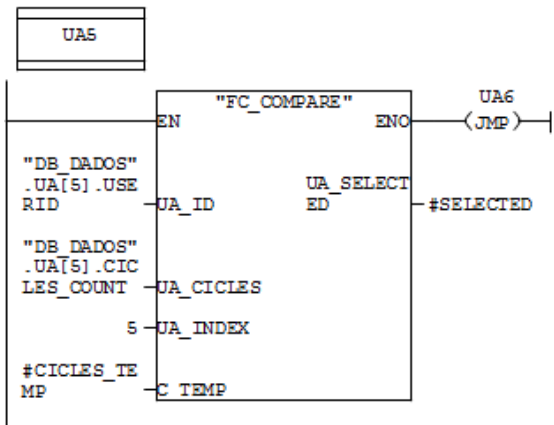

Symbol information  
 FC2 FC\_COMPARE Verifica se a posicao esta vazia e devolve a sua contagem de ciclos  
 DB1.DBW42 "DB\_DADOS".UA[5].USERID Identificacao do utilizador registado na UA  
 DB1.DBW44 "DB\_DADOS".UA[5].CICLES\_COUNT Registro do numero de ciclos da UA

Network: 8 UA6

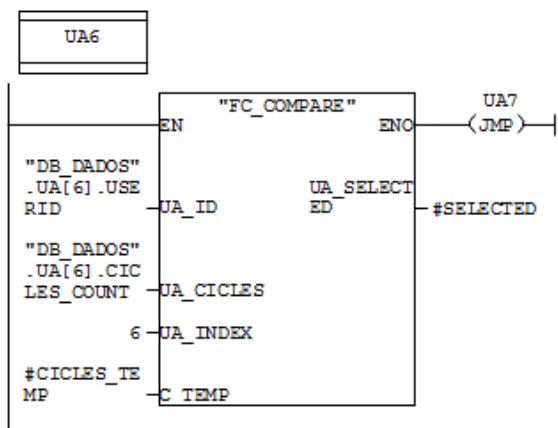

Symbol information  
 FC2 FC\_COMPARE Verifica se a posicao esta vazia e devolve a sua contagem de ciclos  
 DB1.DBW52 "DB\_DADOS".UA[6].USERID Identificacao do utilizador registado na UA  
 DB1.DBW54 "DB\_DADOS".UA[6].CICLES\_COUNT Registo do numero de ciclos da UA

Network: 9 UA7

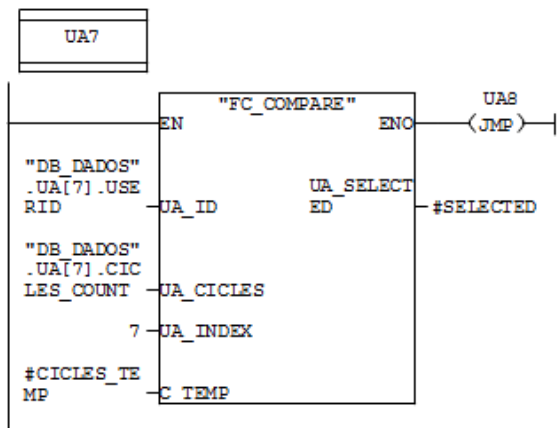

Symbol information  
 FC2 FC\_COMPARE Verifica se a posicao esta vazia e devolve a sua contagem de ciclos  
 DB1.DBW62 "DB\_DADOS".UA[7].USERID Identificacao do utilizador registado na UA  
 DB1.DBW64 "DB\_DADOS".UA[7].CICLES\_COUNT Registo do numero de ciclos da UA

Network: 10 UA8

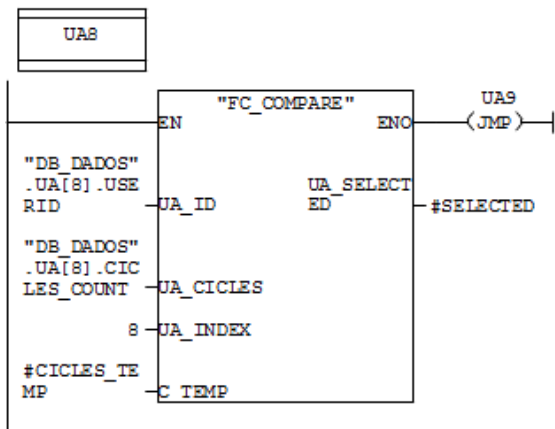

Symbol information  
 FC2 FC\_COMPARE Verifica se a posicao esta vazia e devolve a sua contagem de ciclos  
 DB1.DBW72 "DB\_DADOS".UA[8].USERID Identificacao do utilizador registado na UA  
 DB1.DBW74 "DB\_DADOS".UA[8].CICLES\_COUNT Registo do numero de ciclos da UA

Network: 11 UA9

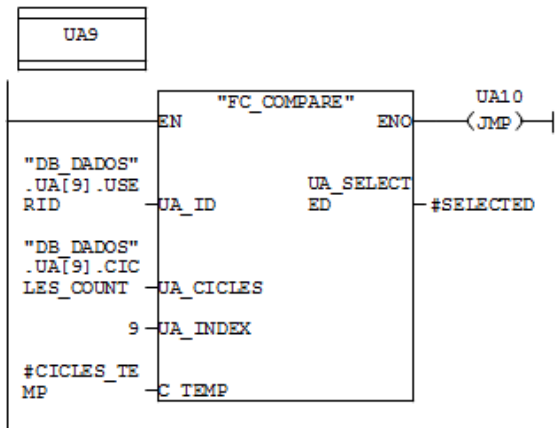

Symbol information  
 FC2 FC\_COMPARE Verifica se a posicao esta vazia e devolve a sua contagem de ciclos  
 DB1.DBW82 "DB\_DADOS".UA[9].USERID Identificacao do utilizador registado na UA  
 DB1.DBW84 "DB\_DADOS".UA[9].CICLES\_COUNT Registo do numero de ciclos da UA

Network: 12 UA10

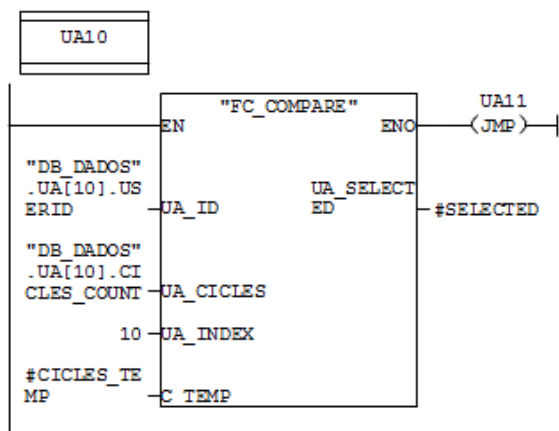

Symbol information  
 FC2 FC\_COMPARE Verifica se a posicao esta vazia e devolve a sua contagem de ciclos  
 DB1.DBW92 "DB\_DADOS".UA[10].USERID Identificacao do utilizador registado na UA  
 DB1.DBW94 "DB\_DADOS".UA[10].CICLES\_COUNT Registo do numero de ciclos da UA

Network: 13 UA11

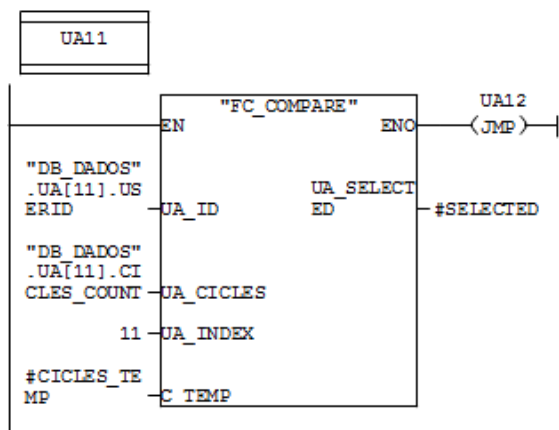

Symbol information  
 FC2 FC\_COMPARE Verifica se a posicao esta vazia e devolve a sua contagem de ciclos  
 DB1.DBW102 "DB\_DADOS".UA[11].USERID Identificacao do utilizador registado na UA  
 DB1.DBW104 "DB\_DADOS".UA[11].CICLES\_COUNT Registo do numero de ciclos da UA

Network: 14 UA12

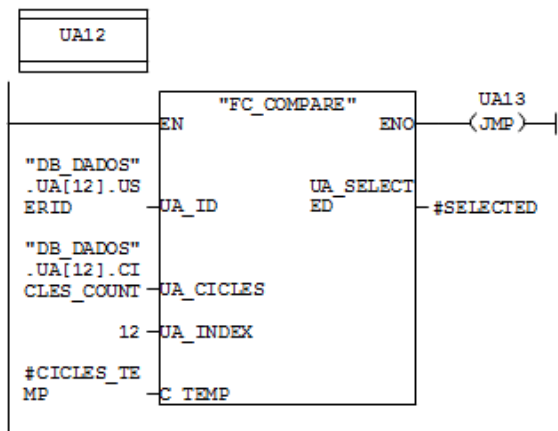

Symbol information  
 FC2 FC\_COMPARE Verifica se a posicao esta vazia e devolve a sua contagem de ciclos  
 DB1.DBW112 "DB\_DADOS".UA[12].USERID Identificacao do utilizador registado na UA  
 DB1.DBW114 "DB\_DADOS".UA[12].CICLES\_COUNT Registo do numero de ciclos da UA

Network: 15 UA13

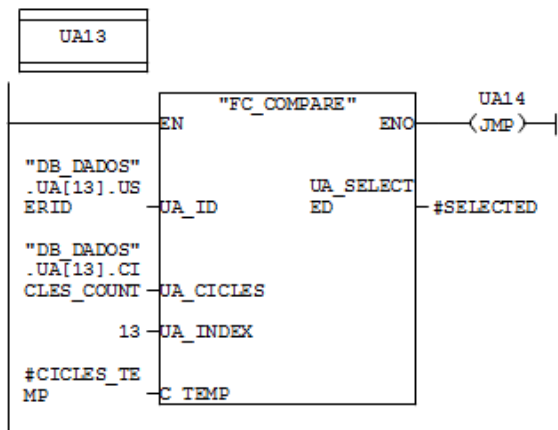

Symbol information  
 FC2 FC\_COMPARE Verifica se a posicao esta vazia e devolve a sua contagem de ciclos  
 DB1.DBW122 "DB\_DADOS".UA[13].USERID Identificacao do utilizador registado na UA  
 DB1.DBW124 "DB\_DADOS".UA[13].CICLES\_COUNT Registo do numero de ciclos da UA

Network: 16 UA14

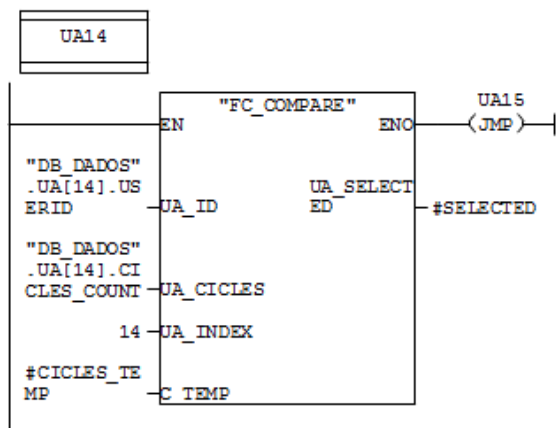

Symbol information  
 FC2 FC\_COMPARE Verifica se a posicao esta vazia e devolve a sua contagem de ciclos  
 DB1.DBW132 "DB\_DADOS".UA[14].USERID Identificacao do utilizador registado na UA  
 DB1.DBW134 "DB\_DADOS".UA[14].CICLES\_COUNT Registo do numero de ciclos da UA

Network: 17 UA15

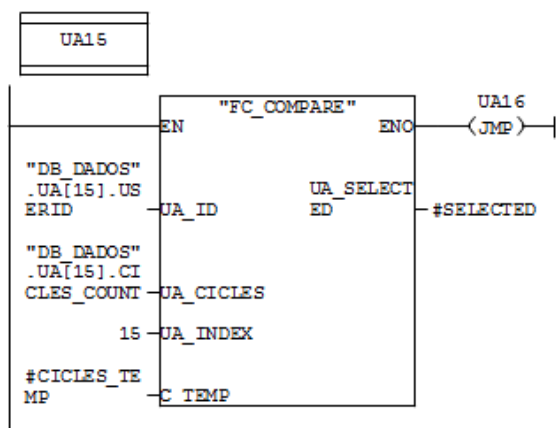

Symbol information  
 FC2 FC\_COMPARE Verifica se a posicao esta vazia e devolve a sua contagem de ciclos  
 DB1.DBW142 "DB\_DADOS".UA[15].USERID Identificacao do utilizador registado na UA  
 DB1.DBW144 "DB\_DADOS".UA[15].CICLES\_COUNT Registo do numero de ciclos da UA

Network: 18 UA16

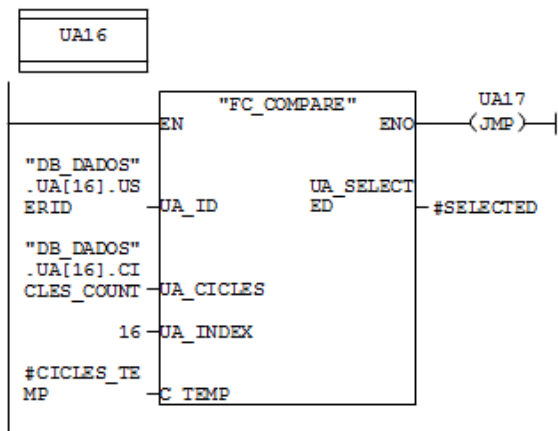

Symbol information  
 FC2 FC\_COMPARE Verifica se a posicao esta vazia e devolve a sua contagem de ciclos  
 DB1.DBW152 "DB\_DADOS".UA[16].USERID Identificacao do utilizador registado na UA  
 DB1.DBW154 "DB\_DADOS".UA[16].CICLES\_COUNT Registo do numero de ciclos da UA

Network: 19 UA17

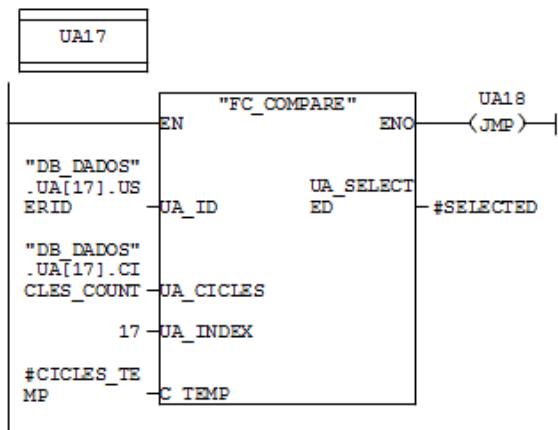

Symbol information  
 FC2 FC\_COMPARE Verifica se a posicao esta vazia e devolve a sua contagem de ciclos  
 DB1.DBW162 "DB\_DADOS".UA[17].USERID Identificacao do utilizador registado na UA  
 DB1.DBW164 "DB\_DADOS".UA[17].CICLES\_COUNT Registo do numero de ciclos da UA

Network: 20 UA18

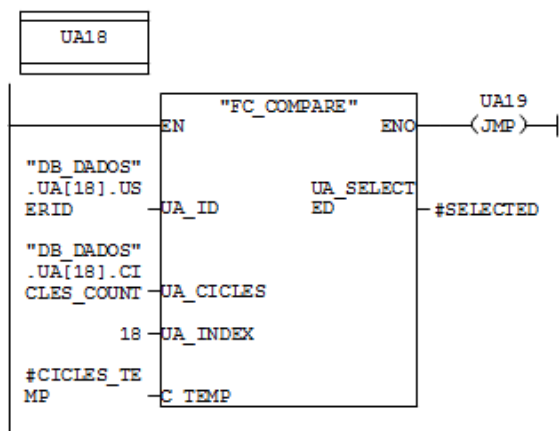

Symbol information  
 FC2 FC\_COMPARE Verifica se a posicao esta vazia e devolve a sua contagem de ciclos  
 DB1.DBW172 "DB\_DADOS".UA[18].USERID Identificacao do utilizador registado na UA  
 DB1.DBW174 "DB\_DADOS".UA[18].CICLES\_COUNT Registo do numero de ciclos da UA

Network: 21 UA19

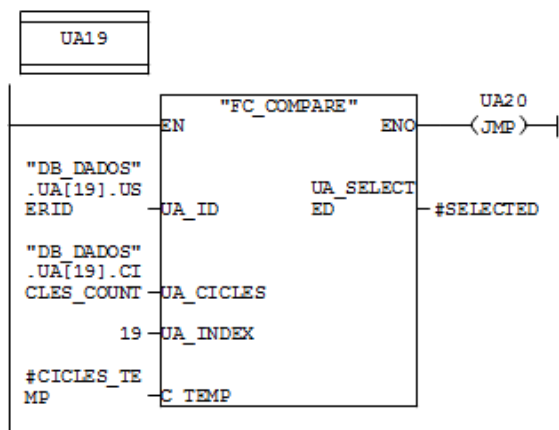

Symbol information  
 FC2 FC\_COMPARE Verifica se a posicao esta vazia e devolve a sua contagem de ciclos  
 DB1.DBW182 "DB\_DADOS".UA[19].USERID Identificacao do utilizador registado na UA  
 DB1.DBW184 "DB\_DADOS".UA[19].CICLES\_COUNT Registo do numero de ciclos da UA

Network: 22 UA20

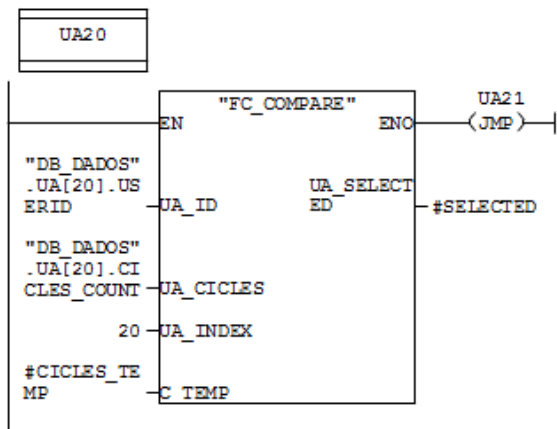

Symbol information  
 FC2 FC\_COMPARE Verifica se a posicao esta vazia e devolve a sua contagem de ciclos  
 DB1.DBW192 "DB\_DADOS".UA[20].USERID Identificacao do utilizador registado na UA  
 DB1.DBW194 "DB\_DADOS".UA[20].CICLES\_COUNT Registo do numero de ciclos da UA

Network: 23 UA21

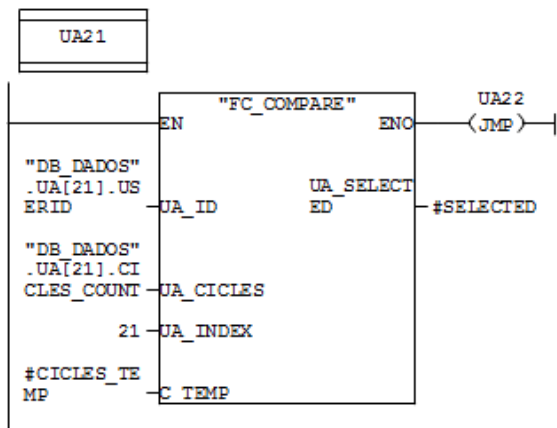

Symbol information  
 FC2 FC\_COMPARE Verifica se a posicao esta vazia e devolve a sua contagem de ciclos  
 DB1.DBW202 "DB\_DADOS".UA[21].USERID Identificacao do utilizador registado na UA  
 DB1.DBW204 "DB\_DADOS".UA[21].CICLES\_COUNT Registo do numero de ciclos da UA

Network: 24 UA22

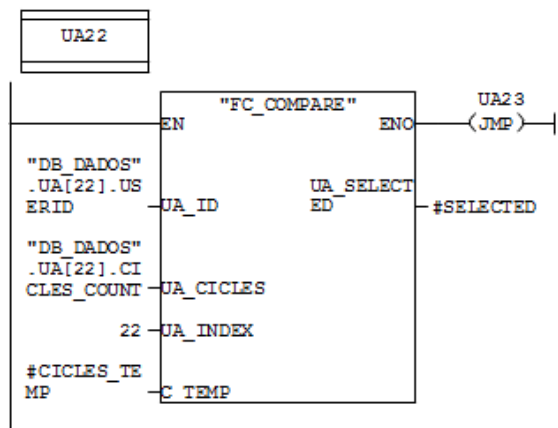

Symbol information  
 FC2 FC\_COMPARE Verifica se a posicao esta vazia e devolve a sua contagem de ciclos  
 DB1.DBW212 "DB\_DADOS".UA[22].USERID Identificacao do utilizador registado na UA  
 DB1.DBW214 "DB\_DADOS".UA[22].CICLES\_COUNT Registo do numero de ciclos da UA

Network: 25 UA23

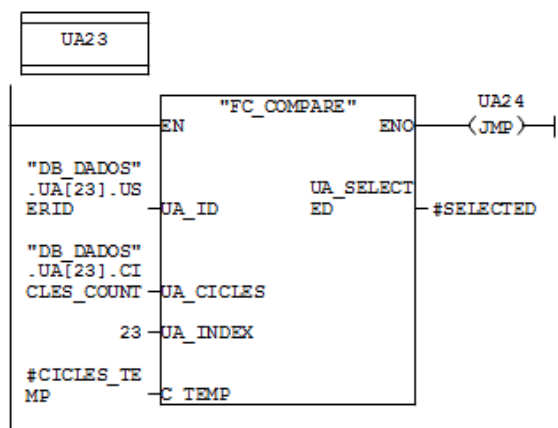

Symbol information  
 FC2 FC\_COMPARE Verifica se a posicao esta vazia e devolve a sua contagem de ciclos  
 DB1.DBW222 "DB\_DADOS".UA[23].USERID Identificacao do utilizador registado na UA  
 DB1.DBW224 "DB\_DADOS".UA[23].CICLES\_COUNT Registo do numero de ciclos da UA

Network: 26 UA24

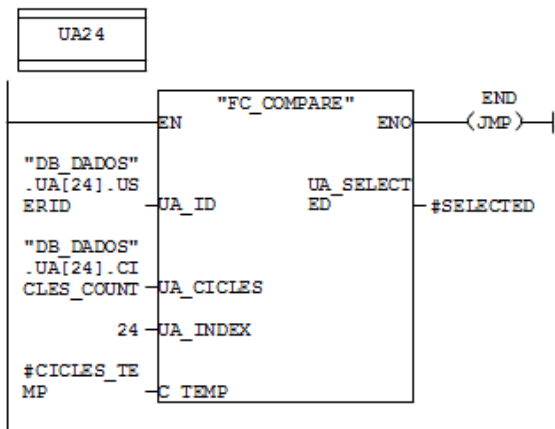

Symbol information  
 FC2 FC\_COMPARE Verifica se a posicao esta vazia e devolve a sua contagem de ciclos  
 DB1.DBW232 "DB\_DADOS".UA[24].USERID Identificacao do utilizador registado na UA  
 DB1.DBW234 "DB\_DADOS".UA[24].CICLES\_COUNT Registo do numero de ciclos da UA

Network: 27 END

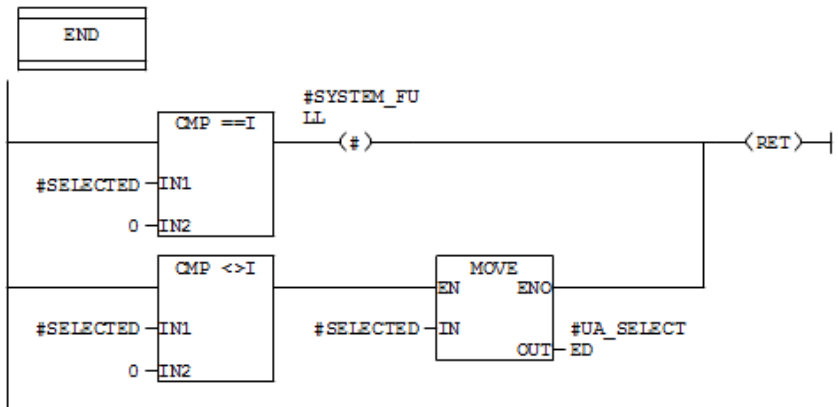

## **ANEXO II-VI**

### **FC4 “FC\_SEARCH\_ID”**

SIMATIC ...trolador\CPU 314IFM-CPU...\FC4 - <offline> 09/21/2011 16:28:24

**FC4 - <offline>**

"FC\_SEARCH\_ID" Procura a UA associada ao ID  
 Name: Family:  
 Author: Version: 0.1  
 Block version: 2  
 Time stampCode: 21-09-2011 12:34:08  
 Interface: 06-07-2011 15:06:07  
 Lengths (block/logic/data): 01102 00834 00008

Address	Declaration	Name	Type	Initial value	Comment
0.0	in	USER_ID	INT		Identificacao do utilizador
2.0	out	UA_SELECTED	INT		UA Seleccionada
4.0	out	ID_ERROR	BOOL		Sinaliza um erro caso o utilizador nao existe na DB
	in out				
0.0	temp	M1	BOOL		Memoria temporaria
0.1	temp	M2	BOOL		Memoria temporaria
2.0	temp	SELECT_TEMP	INT		Memoria temporaria
4.0	temp	M-UA	ARRAY[1..24]		Vector com marcacao das posicoes ocupa das
*0.1	temp		BOOL		

Block: FC4 Procura a UA associada ao ID do utilizador

Network: 1 START DATABASE

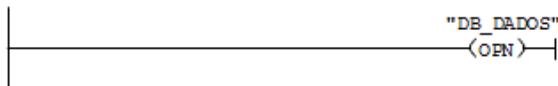

Symbol information  
 DB1 DB\_DADOS Guarda o registo dos utilizadores e dos ciclos de utilizacao

Network: 2

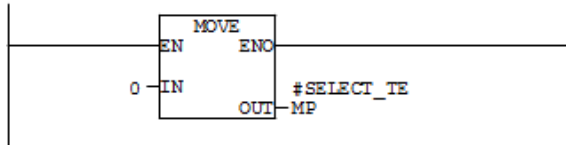

Network: 3 UA1

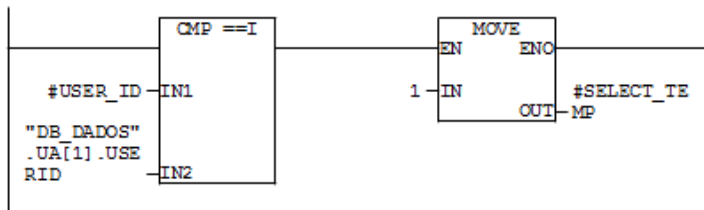

Symbol information  
 DB1.DBW2 "DB\_DADOS".UA[1].USERID Identificacao do utilizador registado na UA

Network: 4 UA2

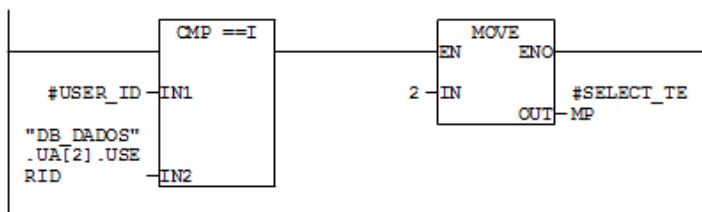

Symbol information  
 DB1.DBW12 "DB\_DADOS".UA[2].USERIDIdentificacao do utilizador registado na UA

Network: 5 UA3

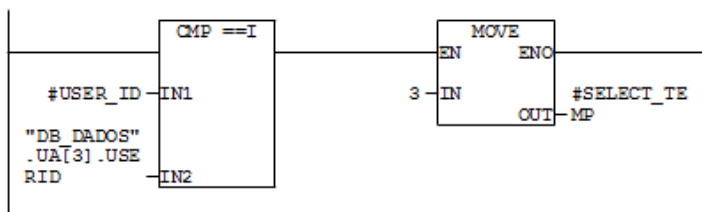

Symbol information  
 DB1.DBW22 "DB\_DADOS".UA[3].USERIDIdentificacao do utilizador registado na UA

Network: 6 UA4

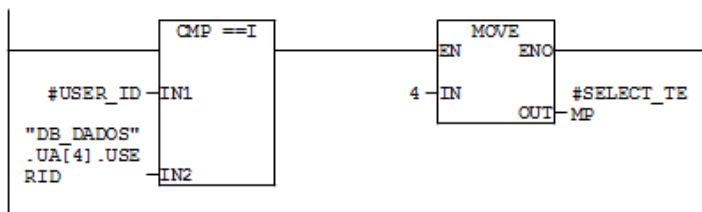

Symbol information  
 DB1.DBW32 "DB\_DADOS".UA[4].USERIDIdentificacao do utilizador registado na UA

Network: 7 UA5

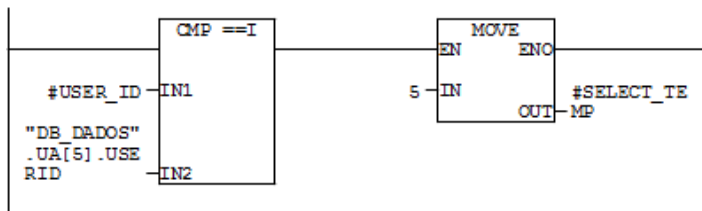

Symbol information  
 DB1.DBW42 "DB\_DADOS".UA[5].USERIDIdentificacao do utilizador registado na UA

Network: 8 UA6

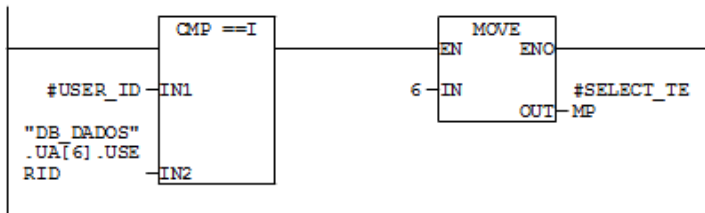

Symbol information  
 DB1.DBW52 "DB\_DADOS".UA[6].USERIDIdentificacao do utilizador registado na UA

Network: 9 UA7

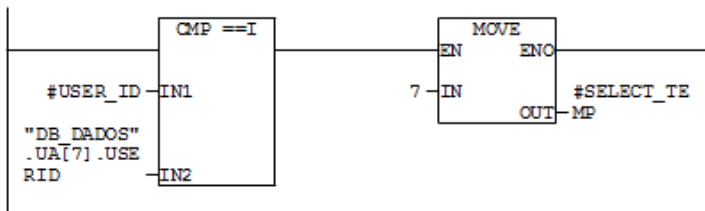

Symbol information  
 DB1.DBW62 "DB\_DADOS".UA[7].USERIDIdentificacao do utilizador registado na UA

Network: 10 UA8

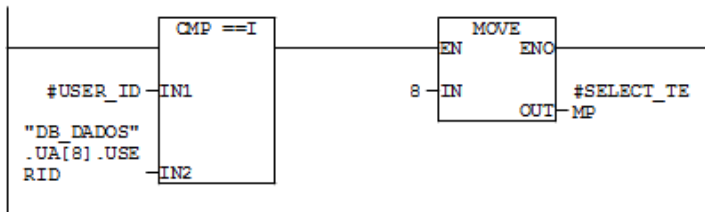

Symbol information  
 DB1.DBW72 "DB\_DADOS".UA[8].USERIDIdentificacao do utilizador registado na UA

Network: 11 UA9

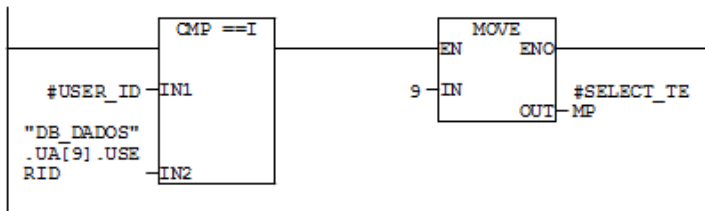

Symbol information  
 DB1.DBW82 "DB\_DADOS".UA[9].USERIDIdentificacao do utilizador registado na UA

Network: 12 UA10

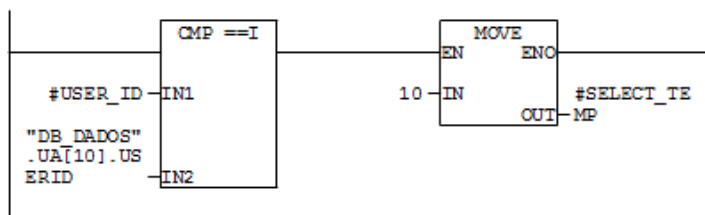

Symbol information  
 DB1.DBW92 "DB\_DADOS".UA[10].USERID Identificacao do utilizador registado na UA

Network: 13 UA11

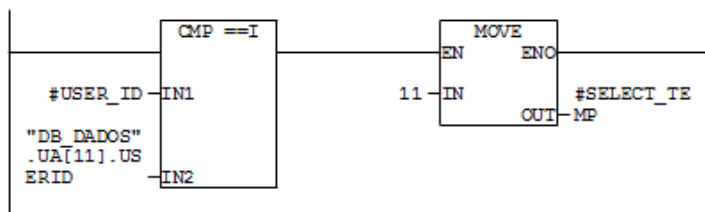

Symbol information  
 DB1.DBW102 "DB\_DADOS".UA[11].USERID Identificacao do utilizador registado na UA

Network: 14 UA12

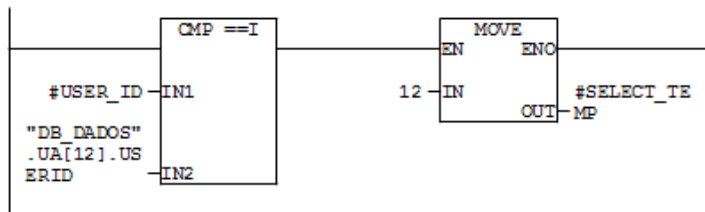

Symbol information  
 DB1.DBW112 "DB\_DADOS".UA[12].USERID Identificacao do utilizador registado na UA

Network: 15 UA13

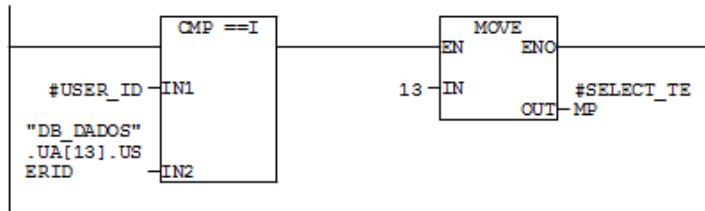

Symbol information  
 DB1.DBW122 "DB\_DADOS".UA[13].USERID Identificacao do utilizador registado na UA

Network: 16 UA14

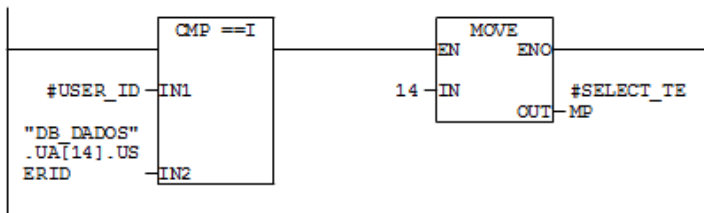

Symbol information  
 DB1.DBW132 "DB\_DADOS".UA[14].USERID Identificacao do utilizador registado na UA

Network: 17 UA15

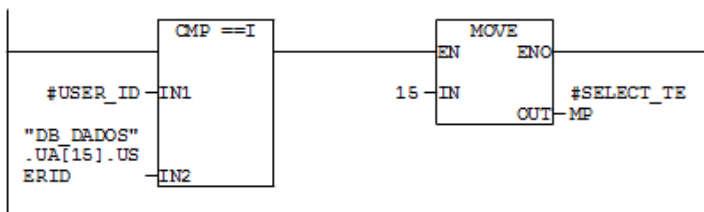

Symbol information  
 DB1.DBW142 "DB\_DADOS".UA[15].USERID Identificacao do utilizador registado na UA

Network: 18 UA16

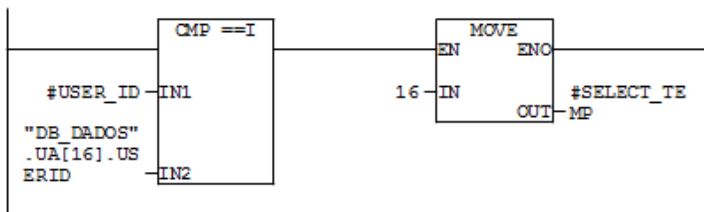

Symbol information  
 DB1.DBW152 "DB\_DADOS".UA[16].USERID Identificacao do utilizador registado na UA

Network: 19 UA17

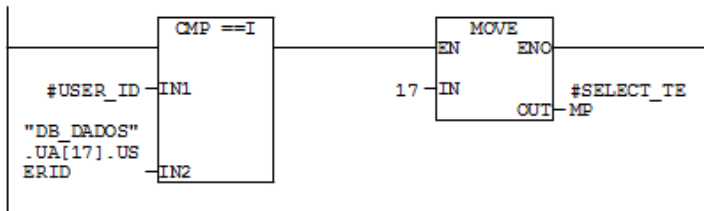

Symbol information  
 DB1.DBW162 "DB\_DADOS".UA[17].USERID Identificacao do utilizador registado na UA

Network: 20 UA18

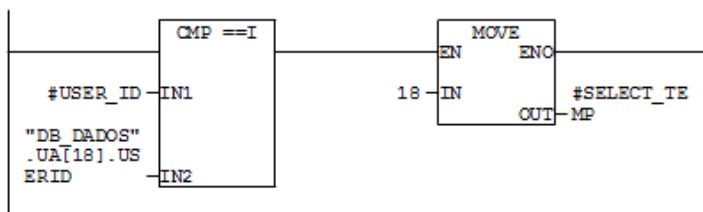

Symbol information  
 DB1.DBW172 "DB\_DADOS".UA[18].USERID Identificacao do utilizador registado na UA

Network: 21 UA19

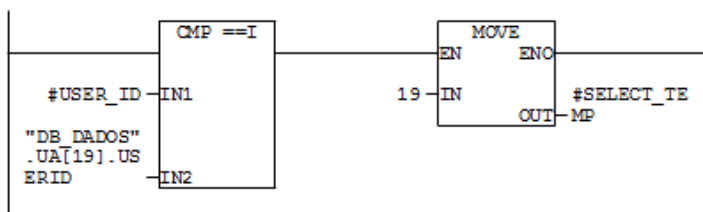

Symbol information  
 DB1.DBW182 "DB\_DADOS".UA[19].USERID Identificacao do utilizador registado na UA

Network: 22 UA20

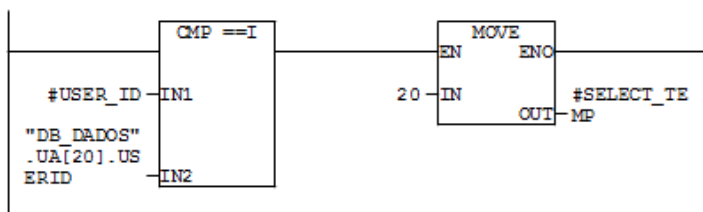

Symbol information  
 DB1.DBW192 "DB\_DADOS".UA[20].USERID Identificacao do utilizador registado na UA

Network: 23 UA21

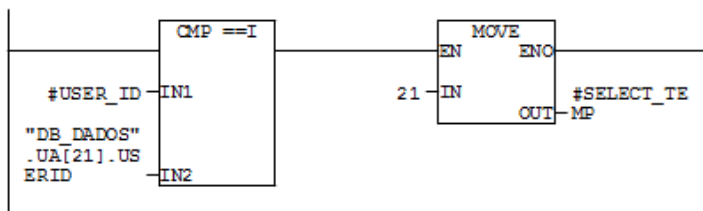

Symbol information  
 DB1.DBW202 "DB\_DADOS".UA[21].USERID Identificacao do utilizador registado na UA

Network: 24 UA22

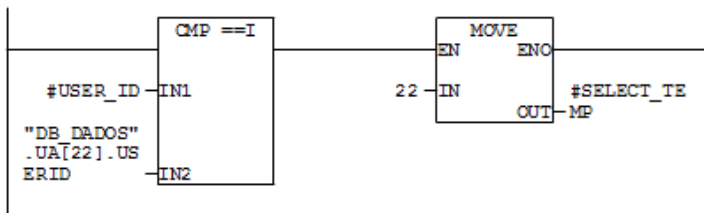

Symbol information  
 DB1.DBW212 "DB\_DADOS".UA[22].USERID Identificacao do utilizador registado na UA

Network: 25 UA23

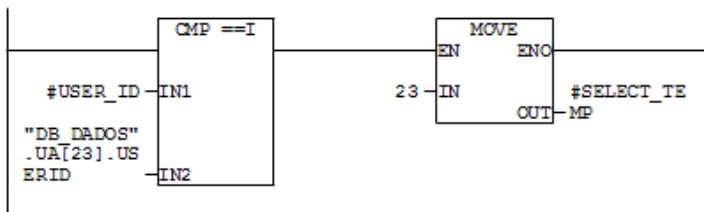

Symbol information  
 DB1.DBW222 "DB\_DADOS".UA[23].USERID Identificacao do utilizador registado na UA

Network: 26 UA24

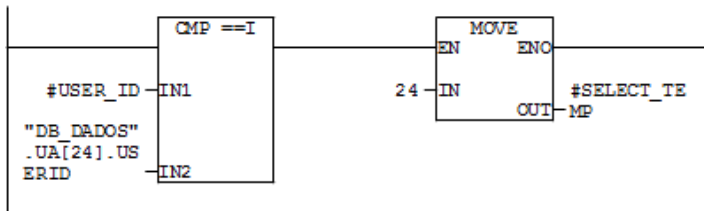

Symbol information  
 DB1.DBW232 "DB\_DADOS".UA[24].USERID Identificacao do utilizador registado na UA

Network: 27 ERROR

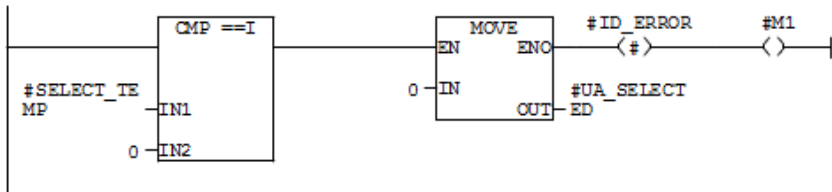

Network: 28 SEARCH OK

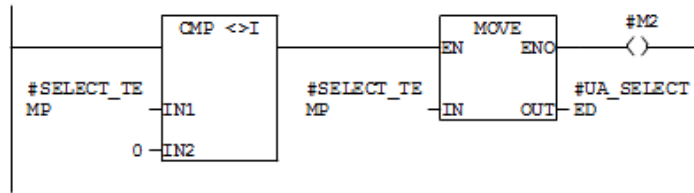

Network: 29

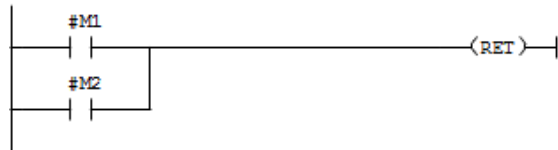



## **ANEXO II-VII**

### **FC5 “FC\_GO\_POSITION”**

**FC5 - <offline>**

"FC\_GO\_POSITION" Funcao que cordena o movimento do MA para a ZER  
 Name: Family:  
 Author: Version: 0.1  
 Block version: 2  
 Time stampCode: 07-09-2011 17:35:56  
 Interface: 07-09-2011 17:35:56  
 Lengths (block/logic/data): 03140 02886 00008

Address	Declaration	Name	Type	Initial value	Comment
0.0	in	UA_INDEX	INT		Index da UA objectivo
2.0	in	START	BOOL		START
	out				
	in out				
0.0	temp	M_TEMP	BOOL		
0.1	temp	MPOS1	BOOL		Memoria temporaria
2.0	temp	M_UA	ARRAY[1..24]		Vector posicoes
*0.1	temp		BOOL		

Block: FC5 Funcao que cordena os movimentos do robo HOME->POSICAO

Network: 1 UA1

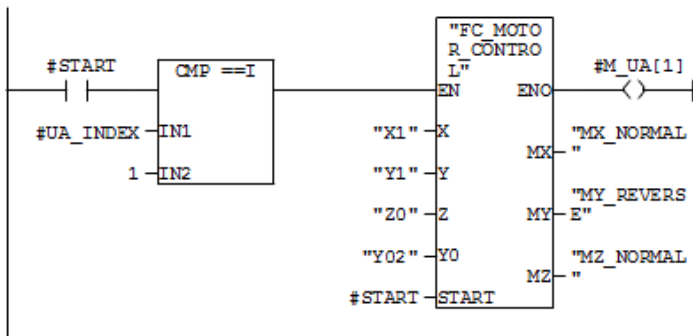

Symbol information  
 FC1 FC\_MOTOR\_CONTROL Controla o movimento dos motores  
 I124.0 X1  
 I125.6 Y1  
 I125.3 Z0  
 I126.3 Y02 Posicao de transporte 2  
 Q125.0 MX\_NORMAL Motor X - Sentido Normal  
 Q125.3 MY\_REVERSE Motor Y - Sentido Reverso  
 Q125.4 MZ\_NORMAL Motor Z - Sentido Normal

Network: 2 UA2

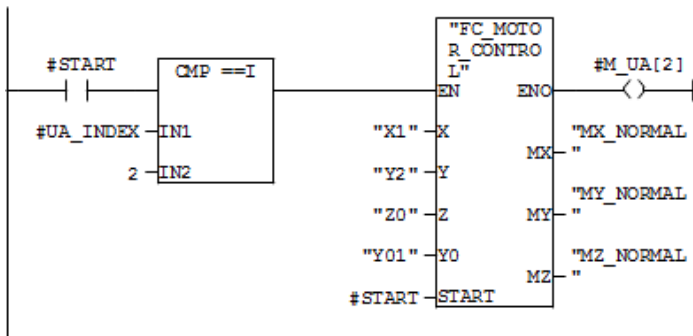

Symbol information

FC1	FC_MOTOR_CONTROL	Controla o movimento dos motores
I124.0	X1	
I125.7	Y2	
I125.3	Z0	
I126.2	Y01	Posicao de transporte 1
Q125.0	MX_NORMAL	Motor X - Sentido Normal
Q125.2	MY_NORMAL	Motor Y - Sentido Normal
Q125.4	MZ_NORMAL	Motor Z - Sentido Normal

Network: 3 UA3

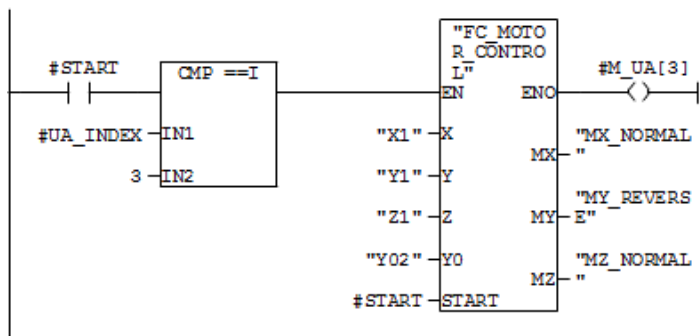

Symbol information

FC1	FC_MOTORES	Controla o movimento dos motores
I124.0	X1	
I125.6	Y1	
I125.4	Z1	
I126.3	Y02	Posicao de transporte 2
Q125.0	MX_NORMAL	Motor X - Sentido Normal
Q125.3	MY_REVERSE	Motor Y - Sentido Reverso
Q125.4	MZ_NORMAL	Motor Z - Sentido Normal

Network: 4 UA4

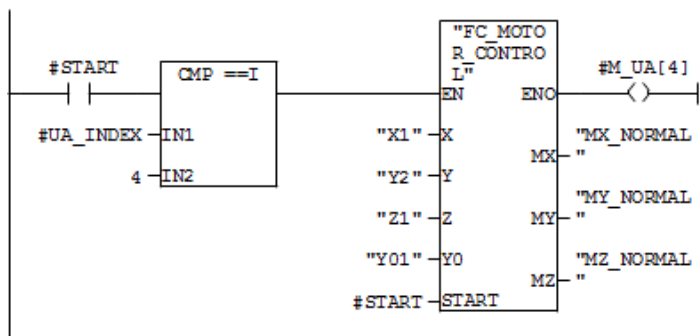

Symbol information

FC1	FC_MOTOR_CONTROL	Controla o movimento dos motores
I124.0	X1	
I125.7	Y2	
I125.4	Z1	
I126.2	Y01	Posicao de transporte 1
Q125.0	MX_NORMAL	Motor X - Sentido Normal
Q125.2	MY_NORMAL	Motor Y - Sentido Normal
Q125.4	MZ_NORMAL	Motor Z - Sentido Normal

Network: 5 UA5

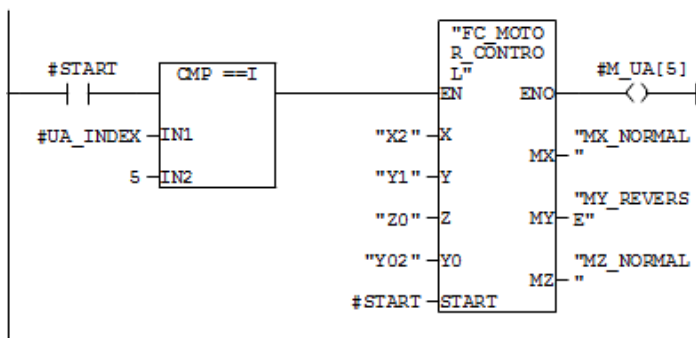

Symbol information  
 FC1 FC\_MOTOR\_CONTROL Controla o movimento dos motores  
 I124.1 X2  
 I125.6 Y1  
 I125.3 Z0  
 I126.3 Y02 Posicao de transporte 2  
 Q125.0 MX\_NORMAL Motor X - Sentido Normal  
 Q125.3 MY\_REVERSE Motor Y - Sentido Reverso  
 Q125.4 MZ\_NORMAL Motor Z - Sentido Normal

Network: 6 UA6

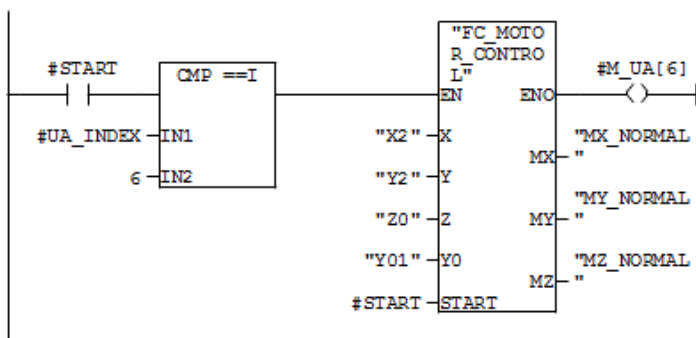

Symbol information  
 FC1 FC\_MOTOR\_CONTROL Controla o movimento dos motores  
 I124.1 X2  
 I125.7 Y2  
 I125.3 Z0  
 I126.2 Y01 Posicao de transporte 1  
 Q125.0 MX\_NORMAL Motor X - Sentido Normal  
 Q125.2 MY\_NORMAL Motor Y - Sentido Normal  
 Q125.4 MZ\_NORMAL Motor Z - Sentido Normal

Network: 7 UA7

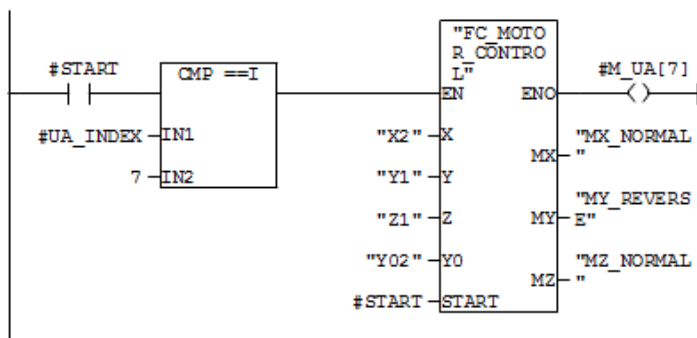

Symbol information

FC1	FC_MOTOR_CONTROL	Controla o movimento dos motores
I124.1	X2	
I125.6	Y1	
I125.4	Z1	
I126.3	Y02	Posicao de transporte 2
Q125.0	MX_NORMAL	Motor X - Sentido Normal
Q125.3	MY_REVERSE	Motor Y - Sentido Reverso
Q125.4	MZ_NORMAL	Motor Z - Sentido Normal

Network: 8 UA8

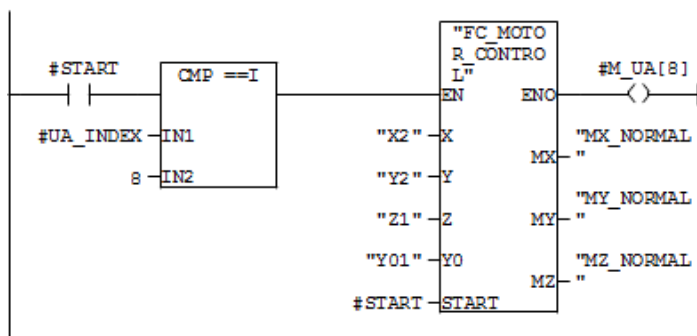

Symbol information

FC1	FC_MOTOR_CONTROL	Controla o movimento dos motores
I124.1	X2	
I125.7	Y2	
I125.4	Z1	
I126.2	Y01	Posicao de transporte 1
Q125.0	MX_NORMAL	Motor X - Sentido Normal
Q125.2	MY_NORMAL	Motor Y - Sentido Normal
Q125.4	MZ_NORMAL	Motor Z - Sentido Normal

Network: 9 UA9

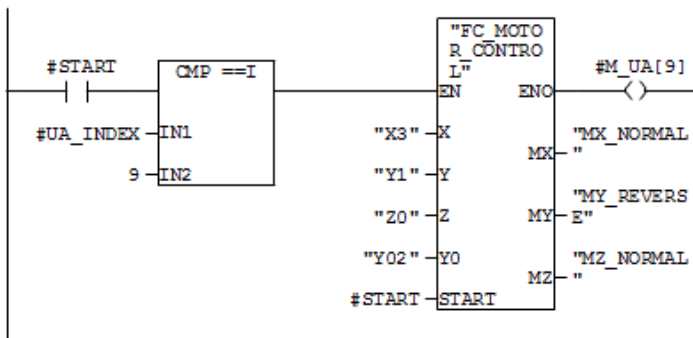

Symbol information

FC1	FC_MOTOR_CONTROL	Controla o movimento dos motores
I124.2	X3	
I125.6	Y1	
I125.3	Z0	
I126.3	Y02	Posicao de transporte 2
Q125.0	MK_NORMAL	Motor X - Sentido Normal
Q125.3	MY_REVERSE	Motor Y - Sentido Reverso
Q125.4	MZ_NORMAL	Motor Z - Sentido Normal

Network: 10 UA10

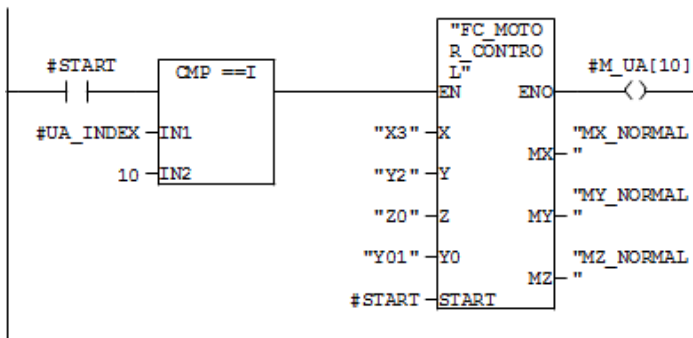

Symbol information

FC1	FC_MOTOR_CONTROL	Controla o movimento dos motores
I124.2	X3	
I125.7	Y2	
I125.3	Z0	
I126.2	Y01	Posicao de transporte 1
Q125.0	MK_NORMAL	Motor X - Sentido Normal
Q125.2	MY_NORMAL	Motor Y - Sentido Normal
Q125.4	MZ_NORMAL	Motor Z - Sentido Normal

Network: 11 UA11

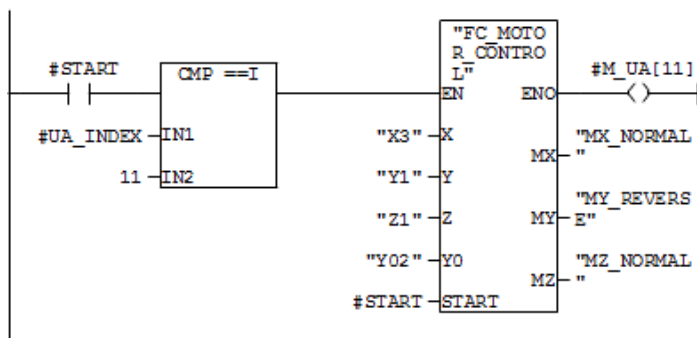

Symbol information

FC1	FC_MOTOR_CONTROL	Controla o movimento dos motores
I124.2	X3	
I125.6	Y1	
I125.4	Z1	
I126.3	Y02	Posicao de transporte 2
Q125.0	MX_NORMAL	Motor X - Sentido Normal
Q125.3	MY_REVERSE	Motor Y - Sentido Reverso
Q125.4	MZ_NORMAL	Motor Z - Sentido Normal

Network: 12 UA12

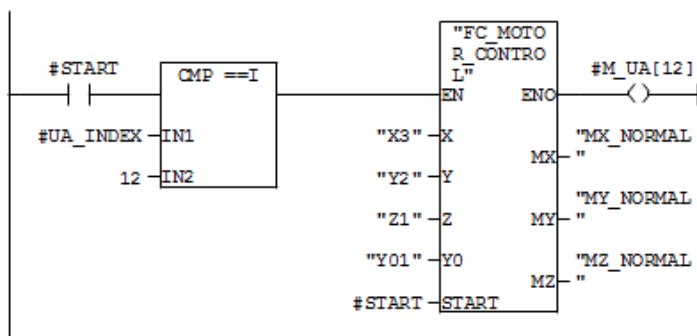

Symbol information

FC1	FC_MOTOR_CONTROL	Controla o movimento dos motores
I124.2	X3	
I125.7	Y2	
I125.4	Z1	
I126.2	Y01	Posicao de transporte 1
Q125.0	MX_NORMAL	Motor X - Sentido Normal
Q125.2	MY_NORMAL	Motor Y - Sentido Normal
Q125.4	MZ_NORMAL	Motor Z - Sentido Normal

Network: 13 UA13

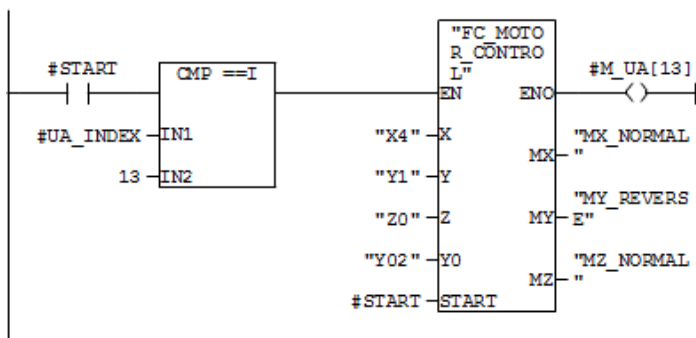

Symbol information

FC1	FC_MOTOR_CONTROL	Controla o movimento dos motores
I124.3	X4	
I125.6	Y1	
I125.3	Z0	
I126.3	Y02	Posicao de transporte 2
Q125.0	MX_NORMAL	Motor X - Sentido Normal
Q125.3	MY_REVERSE	Motor Y - Sentido Reverso
Q125.4	MZ_NORMAL	Motor Z - Sentido Normal

Network: 14 UA14

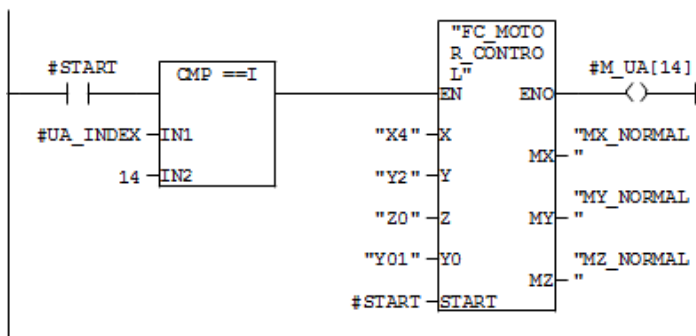

Symbol information

FC1	FC_MOTOR_CONTROL	Controla o movimento dos motores
I124.3	X4	
I125.7	Y2	
I125.3	Z0	
I126.2	Y01	Posicao de transporte 1
Q125.0	MX_NORMAL	Motor X - Sentido Normal
Q125.2	MY_NORMAL	Motor Y - Sentido Normal
Q125.4	MZ_NORMAL	Motor Z - Sentido Normal

Network: 15 UA15

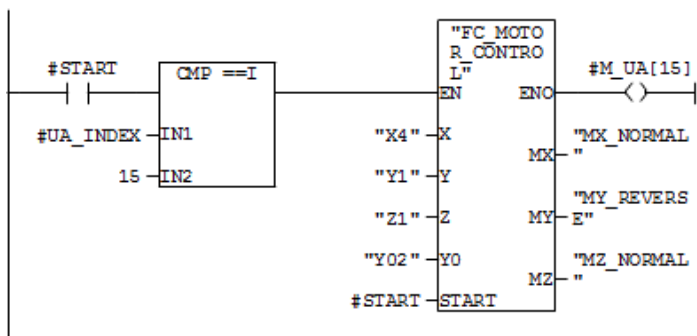

Symbol information

FC1	FC_MOTOR_CONTROL	Controla o movimento dos motores
I124.3	X4	
I125.6	Y1	
I125.4	Z1	
I126.3	Y02	Posicao de transporte 2
Q125.0	MX_NORMAL	Motor X - Sentido Normal
Q125.3	MY_REVERSE	Motor Y - Sentido Reverso
Q125.4	MZ_NORMAL	Motor Z - Sentido Normal

Network: 16 UA16

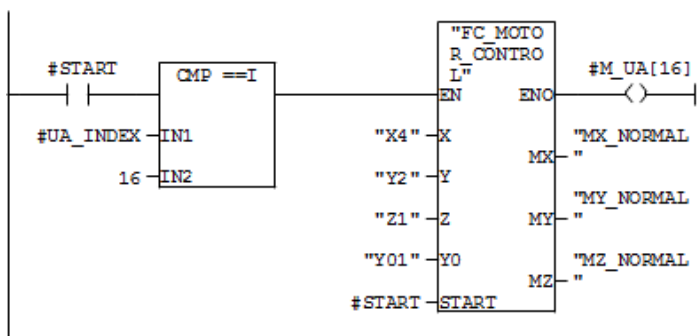

Symbol information

FC1	FC_MOTOR_CONTROL	Controla o movimento dos motores
I124.3	X4	
I125.7	Y2	
I125.4	Z1	
I126.2	Y01	Posicao de transporte 1
Q125.0	MX_NORMAL	Motor X - Sentido Normal
Q125.2	MY_NORMAL	Motor Y - Sentido Normal
Q125.4	MZ_NORMAL	Motor Z - Sentido Normal

Network: 17 UA17

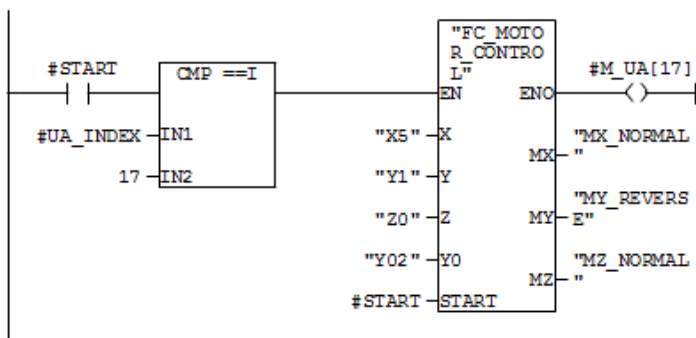

Symbol information  
 FC1 FC\_MOTOR\_CONTROL Controla o movimento dos motores  
 I124.4 X5  
 I125.6 Y1  
 I125.3 Z0  
 I126.3 Y02 Posicao de transporte 2  
 Q125.0 MX\_NORMAL Motor X - Sentido Normal  
 Q125.3 MY\_REVERSE Motor Y - Sentido Reverso  
 Q125.4 MZ\_NORMAL Motor Z - Sentido Normal

Network: 18 UA18

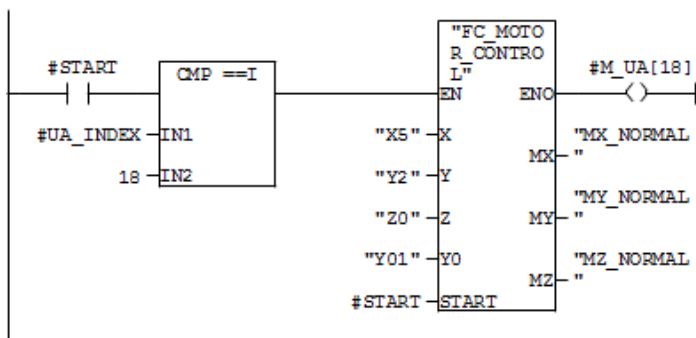

Symbol information  
 FC1 FC\_MOTOR\_CONTROL Controla o movimento dos motores  
 I124.4 X5  
 I125.7 Y2  
 I125.3 Z0  
 I126.2 Y01 Posicao de transporte 1  
 Q125.0 MX\_NORMAL Motor X - Sentido Normal  
 Q125.2 MY\_NORMAL Motor Y - Sentido Normal  
 Q125.4 MZ\_NORMAL Motor Z - Sentido Normal

Network: 19 UA19

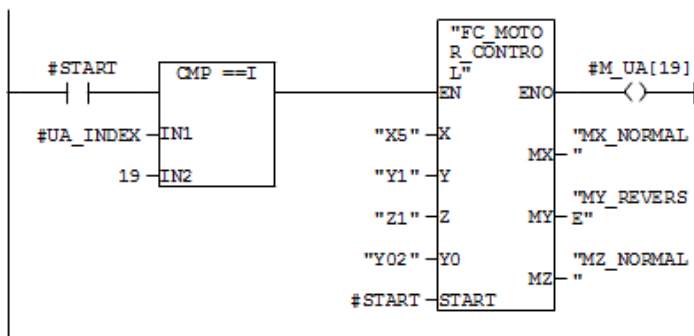

Symbol information

FC1	FC_MOTOR_CONTROL	Controla o movimento dos motores
I124.4	X5	
I125.6	Y1	
I125.4	Z1	
I126.3	Y02	Posicao de transporte 2
Q125.0	MX_NORMAL	Motor X - Sentido Normal
Q125.3	MY_REVERSE	Motor Y - Sentido Reverso
Q125.4	MZ_NORMAL	Motor Z - Sentido Normal

Network: 20 UA20

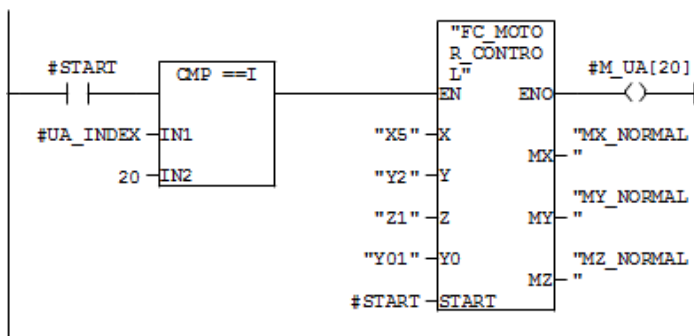

Symbol information

FC1	FC_MOTOR_CONTROL	Controla o movimento dos motores
I124.4	X5	
I125.7	Y2	
I125.4	Z1	
I126.2	Y01	Posicao de transporte 1
Q125.0	MX_NORMAL	Motor X - Sentido Normal
Q125.2	MY_NORMAL	Motor Y - Sentido Normal
Q125.4	MZ_NORMAL	Motor Z - Sentido Normal

Network: 21 UA21

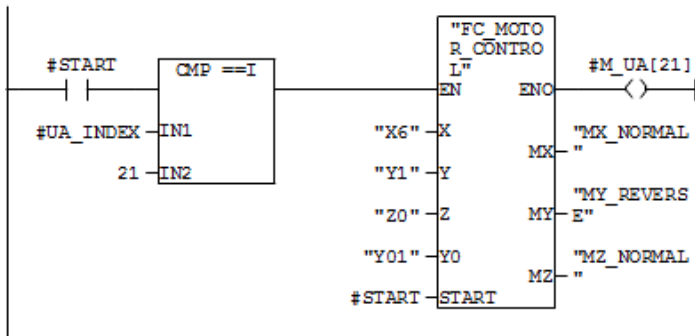

Symbol information  
 FC1 FC\_MOTOR\_CONTROL Controla o movimento dos motores  
 I124.5 X6  
 I125.6 Y1  
 I125.3 Z0  
 I126.2 Y01 Posicao de transporte 1  
 Q125.0 MX\_NORMAL Motor X - Sentido Normal  
 Q125.3 MY\_REVERSE Motor Y - Sentido Reverso  
 Q125.4 MZ\_NORMAL Motor Z - Sentido Normal

Network: 22 UA22

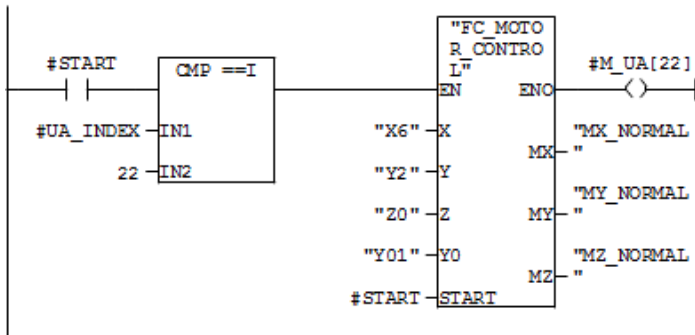

Symbol information  
 FC1 FC\_MOTOR\_CONTROL Controla o movimento dos motores  
 I124.5 X6  
 I125.7 Y2  
 I125.3 Z0  
 I126.2 Y01 Posicao de transporte 1  
 Q125.0 MX\_NORMAL Motor X - Sentido Normal  
 Q125.2 MY\_NORMAL Motor Y - Sentido Normal  
 Q125.4 MZ\_NORMAL Motor Z - Sentido Normal

Network: 23 UA23

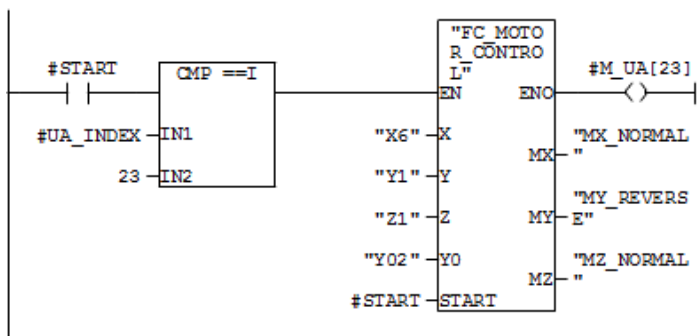

Symbol information

FC1	FC_MOTOR_CONTROL	Controla o movimento dos motores
I124.5	X6	
I125.6	Y1	
I125.4	Z1	
I126.3	Y02	Posicao de transporte 2
Q125.0	MK_NORMAL	Motor X - Sentido Normal
Q125.3	MY_REVERSE	Motor Y - Sentido Reverso
Q125.4	MZ_NORMAL	Motor Z - Sentido Normal

Network: 24 UA24

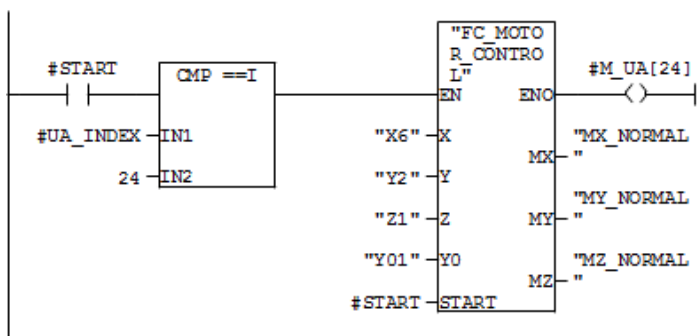

Symbol information

FC1	FC_MOTOR_CONTROL	Controla o movimento dos motores
I124.5	X6	
I125.7	Y2	
I125.4	Z1	
I126.2	Y01	Posicao de transporte 1
Q125.0	MK_NORMAL	Motor X - Sentido Normal
Q125.2	MY_NORMAL	Motor Y - Sentido Normal
Q125.4	MZ_NORMAL	Motor Z - Sentido Normal

Network: 25 Fim

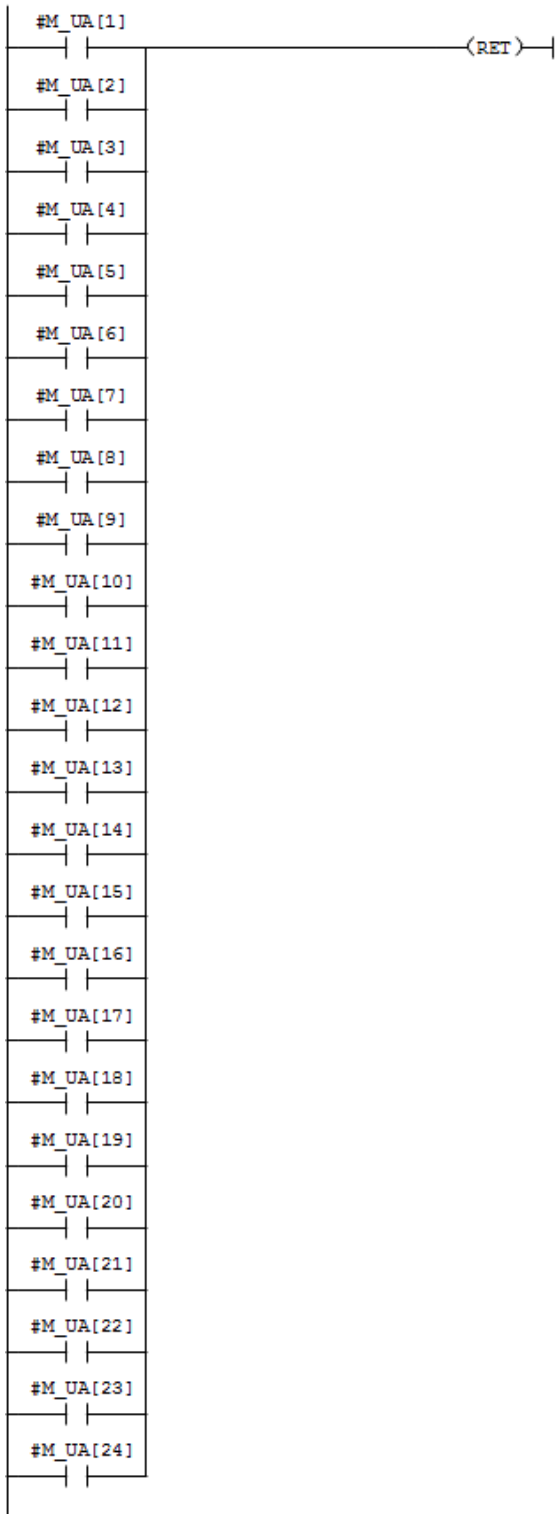

## **ANEXO II-VIII**

### **FC6 “FC\_GO\_HOME”**

**FC6 - <offline>**

"FC\_GO\_HOME" Funcao que cordena o movimento do robo para a posicao HOME  
 Name: Family:  
 Author: Version: 0.1  
 Block version: 2  
 Time stampCode: 08-09-2011 15:56:49  
 Interface: 06-09-2011 16:27:06  
 Lengths (block/logic/data): 00402 00266 00018

Address	Declaration	Name	Type	Initial value	Comment
0.0	in	GOHOME	BOOL		Inicia o processo de ida até a posicao d e repouso do robo
0.1	in	GORECEPTION	BOOL		Coloca o robo em posicao de pesagem da U A
2.0	in	UA_INDEX	INT		Index da UA
	out				
	in_out				
0.0	temp	M1	BOOL		Memoria Temporaria
0.1	temp	Y0	BOOL		Posicao do home
2.0	temp	UA_INDEX_DI	DINT		memoria temporaria
6.0	temp	TWO	DINT		Memoria temporaria
10.0	temp	RESULT_DIVIDE	DINT		Memoria tseporaria
14.0	temp	RESULT_DIVIDE_INT	INT		

Block: FC6 Funcao que cordena os movimentos do robo ate a posicao HOME

Network: 1 Verifica se o indice da posicao e par ou impar

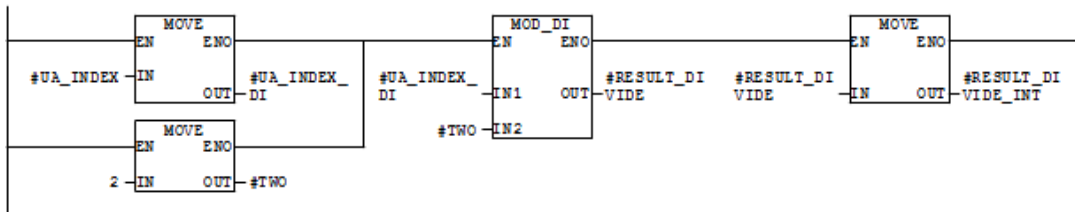

Network: 2 Compara o resto da divisao para ver se e zero

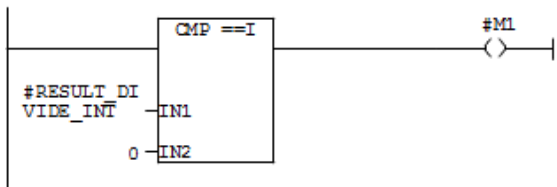

Network: 3

Se o indice da UA for par a posicao da transporte e y02, se for impar e y01

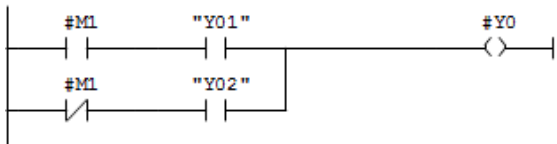

Symbol information  
 I126.2 Y01 Posicao de transporte 1  
 I126.3 Y02 Posicao de transporte 2

Network: 4 controla o motor y

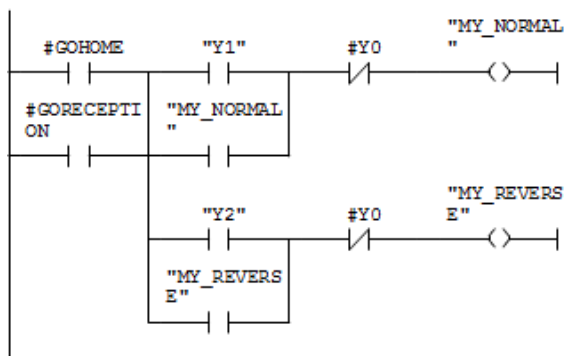

Symbol information

I125.6	Y1	
Q125.2	MY_NORMAL	Motor Y - Sentido Normal
I125.7	Y2	
Q125.3	MY_REVERSE	Motor Y - Sentido Reverso

Network: 5 Controla o motor x e z quando é atingido y0

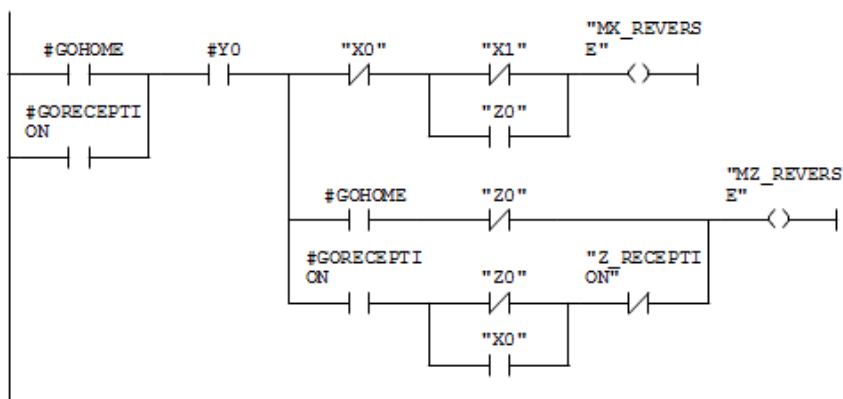

Symbol information

I124.6	X0	
I124.0	X1	
I125.3	Z0	
Q125.1	MX_REVERSE	Motor X - Sentido Reverso
I125.5	Z_RECEPTION	Z na zona de recepção e na zona de pesagem
Q125.5	MZ_REVERSE	Motor Z - Sentido Reverso

Network: 6 Termina a funcao

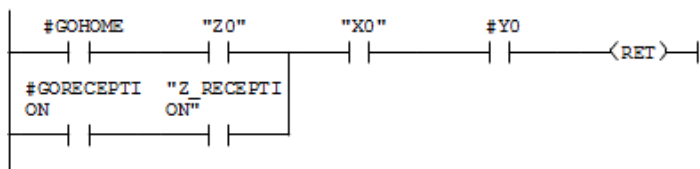

Symbol information

I125.3	Z0	
I125.5	Z_RECEPTION	Z na zona de recepção e na zona de pesagem

SIMATIC ...trolador\CPU 314IFM-CPU...\FC6 - <offline>

09/21/2011 16:28:36

I124.6 X0

## **ANEXO II-IX**

### **FC7 “FC\_CHECK”**

**FC7 - <offline>**

"FC CHECK" Verifica o conteudo da UA  
 Name: Family:  
 Author: Version: 0.1  
 Block version: 2  
 Time stampCode: 08-09-2011 19:49:09  
 Interface: 08-09-2011 12:01:23  
 Lengths (block/logic/data): 00360 00234 00004

Address	Declaration	Name	Type	Initial value	Comment
0.0	in	CHECK_IN	BOOL		Operacao de CheckIn
0.1	in	CHECK_OUT	BOOL		Operacao de CheckOut
2.0	out	OK	BOOL		Conteudo Aceite
2.1	out	FAIL	BOOL		Conteudo Rejeitado
	in out				
0.0	temp	UA WHEIGHT TEMP	INT		Leitura temporaria do peso da UA
2.0	temp	M1	BOOL		Memoria Temporaria 1
2.1	temp	M MASS OK	BOOL		Memoria de peso OK
2.2	temp	M CONTENT OK	BOOL		Memoria da verificacao da UA
2.3	temp	M MASS FAIL	BOOL		Memoria temporaria 2
2.4	temp	M CONTENT FAIL	BOOL		Memoria temporaria 1

Block: FC7

Network: 1 Faz a leitura do peso da UA

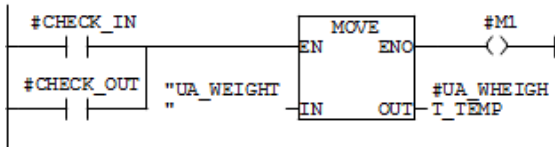

Symbol information  
 PIW128 UA\_WEIGHT Leitura do peso da UA

Network: 2 Verifica as condicoes de peso - check\_in

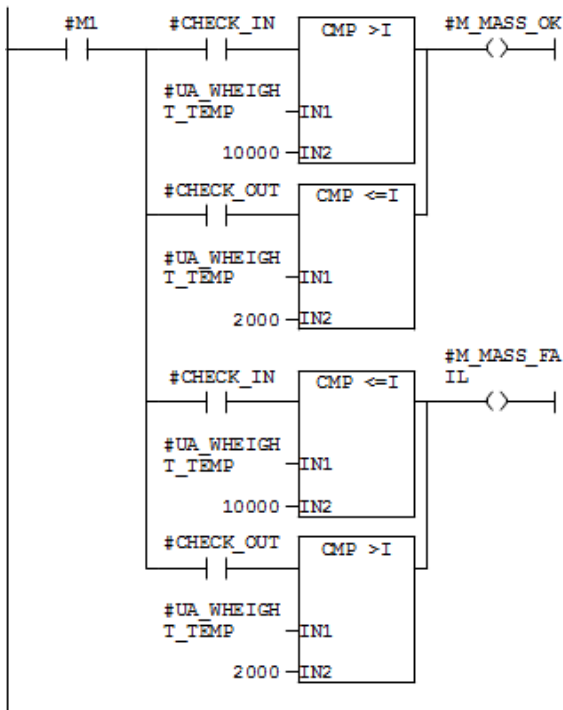

Network: 3 Verifica o interior da UA

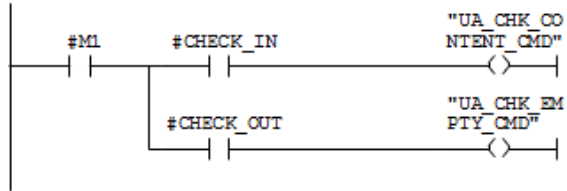

Symbol information

Q125.6 UA\_CHK\_CONTENT\_CMD Comanda a verificacao do interior da UA  
 Q124.5 UA\_CHK\_EMPTY\_CMD Comanda a verificacao para detectar se a UA esta vazia

Network: 4 Define se a o conteudo da ua e validado ou nao

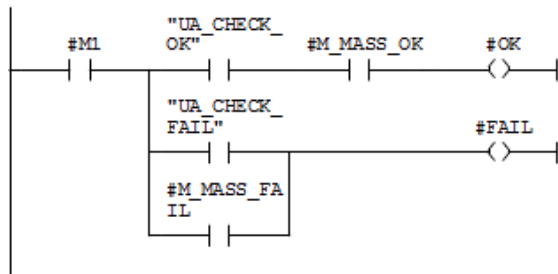

Symbol information

I125.0 UA\_CHECK\_OK Verificacao da UA - Conteudo OK  
 I125.2 UA\_CHECK\_FAIL Verificacao da UA - Conteudo INVALIDO

Network: 5 Termina a funcao

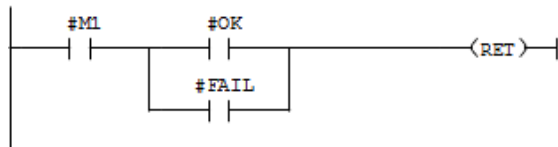



## **ANEXO II-X**

### **FC8 “FC\_REGISTER”**

**FC8 - <offline>**

"FC REGISTER" Regista a operacao de check-in/check-out  
 Name: Family:  
 Author: Version: 0.1  
 Block version: 2  
 Time stampCode: 21-09-2011 16:13:40  
 Interface: 20-07-2011 15:21:11  
 Lengths (block/logic/data): 07702 07036 00044

Address	Declaration	Name	Type	Initial value	Comment
0.0	in	UA_SELECTED	INT		UA Seleccionada
2.0	in	USER_ID	INT		Identificacao do utilizador
4.0	in	CHECK_IN	BOOL		Operacao de check-in
4.1	in	CHECK_OUT	BOOL		Operacao de check-out
6.0	out	TIME_COUNT	TIME		Tempo total do armazenamento
	in_out				
0.0	temp	DATE_ERROR	INT		Erro de leitura da data
2.0	temp	ACTUAL_DT	DATE AND TIME		Data e hora actual
10.0	temp	TIME_COUNT_temp	TIME		Variavel de tempo temporaria
14.0	temp	COUNTER_TEMP	INT		Variavel temporaria do contagem d e ciclos
16.0	temp	ACTUAL_TIME	TIME_OF_DAY		Hora actual
20.0	temp	ACTUAL_DATE	DATE		Data actual
22.0	temp	CHECK_IN_DT	DATE AND TIME		Data e hora de check_in

Block: FC8

Network: 1 LOAD DB

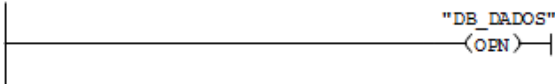

Symbol information  
 DB1 DB\_DADOS Guarda o registo dos utilizadores e dos ciclos de utilizacao

Network: 2 START check-in

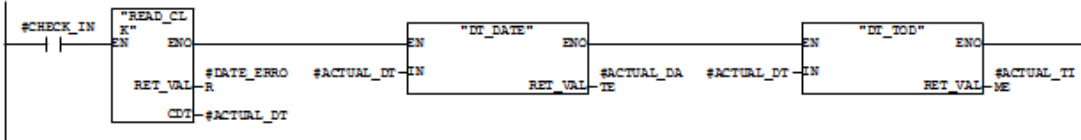

Symbol information  
 SFC1 READ\_CLK Read System Clock  
 FC16 DT\_DATE DT to DATE  
 FC18 DT\_TOD DT to TOD

Network: 3 START check-out

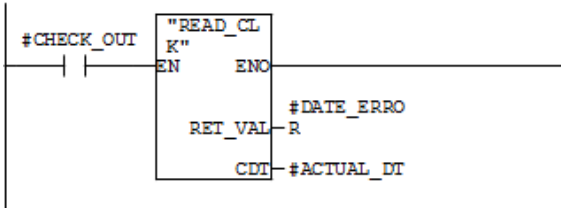

Symbol information  
 SFC1 READ\_CLK Read System Clock

Network: 4 UA 1

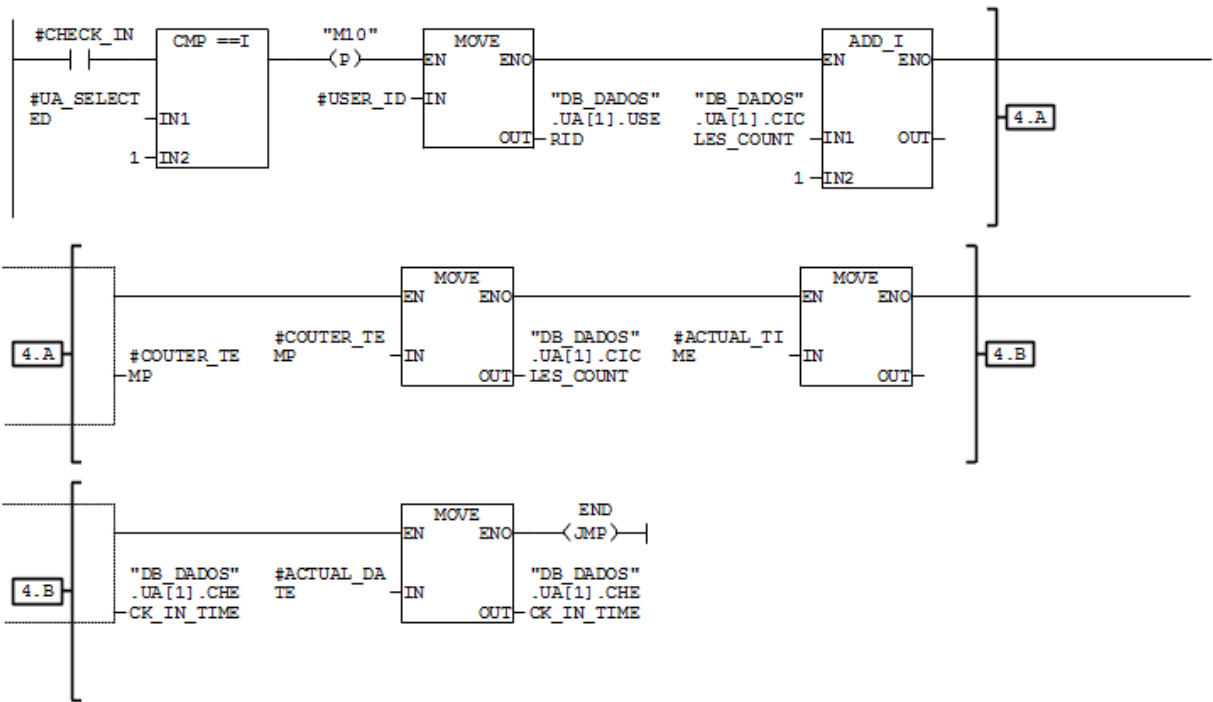

Symbol information

M2.3	M10	
DB1.DEW2	"DB_DADOS".UA[1].USERID	Identificacao do utilizador registado na UA
DB1.DEW4	"DB_DADOS".UA[1].CICLES_COUNT	Registo do numero de ciclos da UA
DB1.DBD6	"DB_DADOS".UA[1].CHECK_IN_TIME	hora do check-in

Network: 5 UA 2

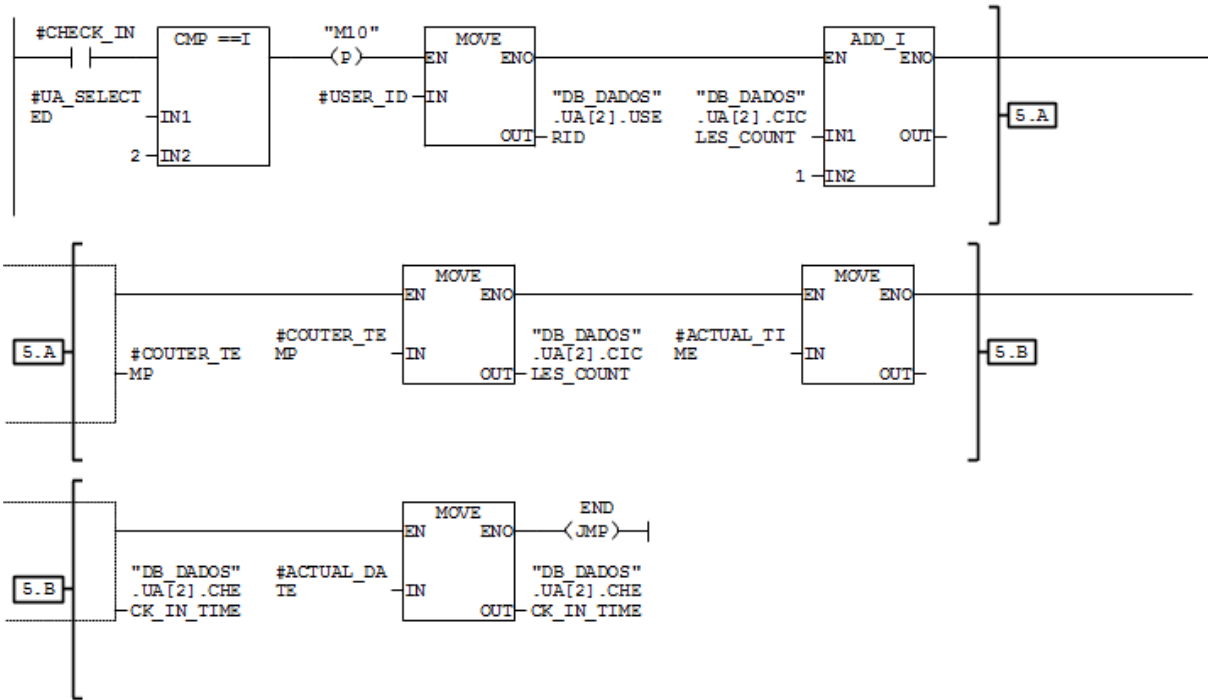

Symbol information

M2.3 M10  
 DB1.DBW12 "DB\_DADOS".UA[2].USERID Identificacao do utilizador registado na UA  
 DB1.DBW14 "DB\_DADOS".UA[2].CICLES\_COUNT Registo do numero de ciclos da UA  
 DB1.DBD16 "DB\_DADOS".UA[2].CHECK\_IN\_TIME hora do check-in

Network: 6 UA 3

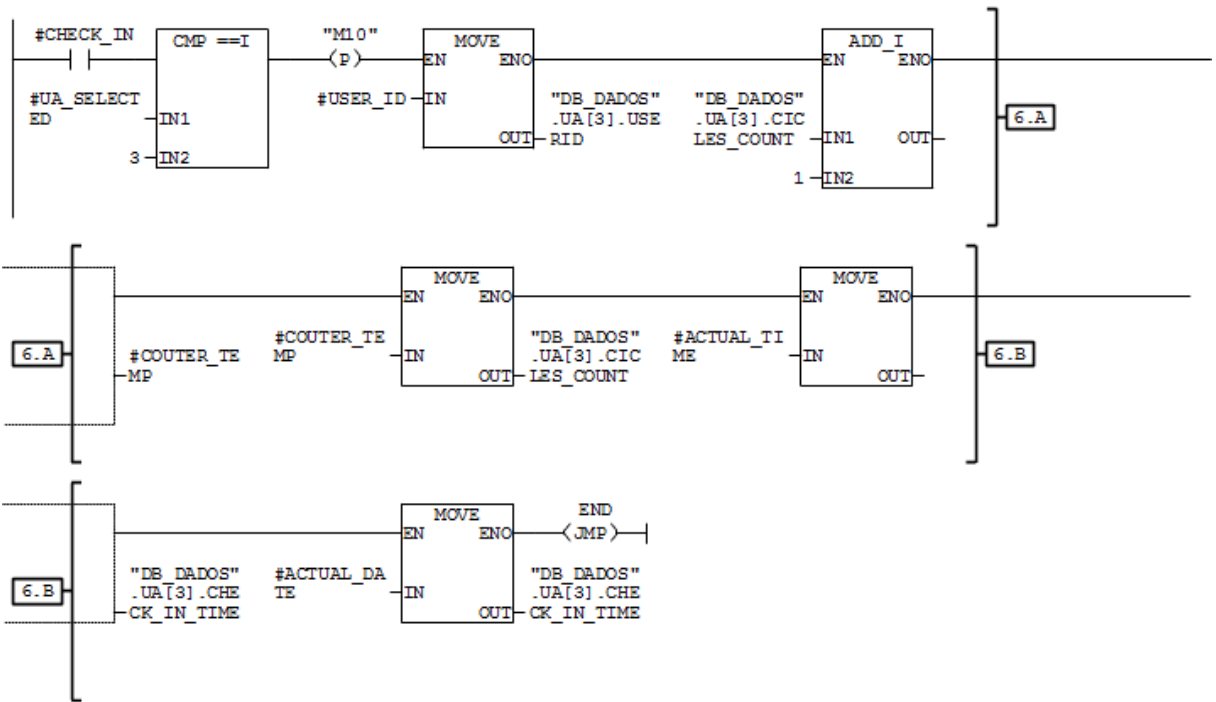

Symbol information

M2.3	M10	
DB1.DEW22	"DB_DADOS".UA[3].USERID	Identificacao do utilizador registado na UA
DB1.DEW24	"DB_DADOS".UA[3].CICLES_COUNT	Registo do numero de ciclos da UA
DB1.DBD26	"DB_DADOS".UA[3].CHECK_IN_TIME	hora do check-in

Network: 7 UA 4

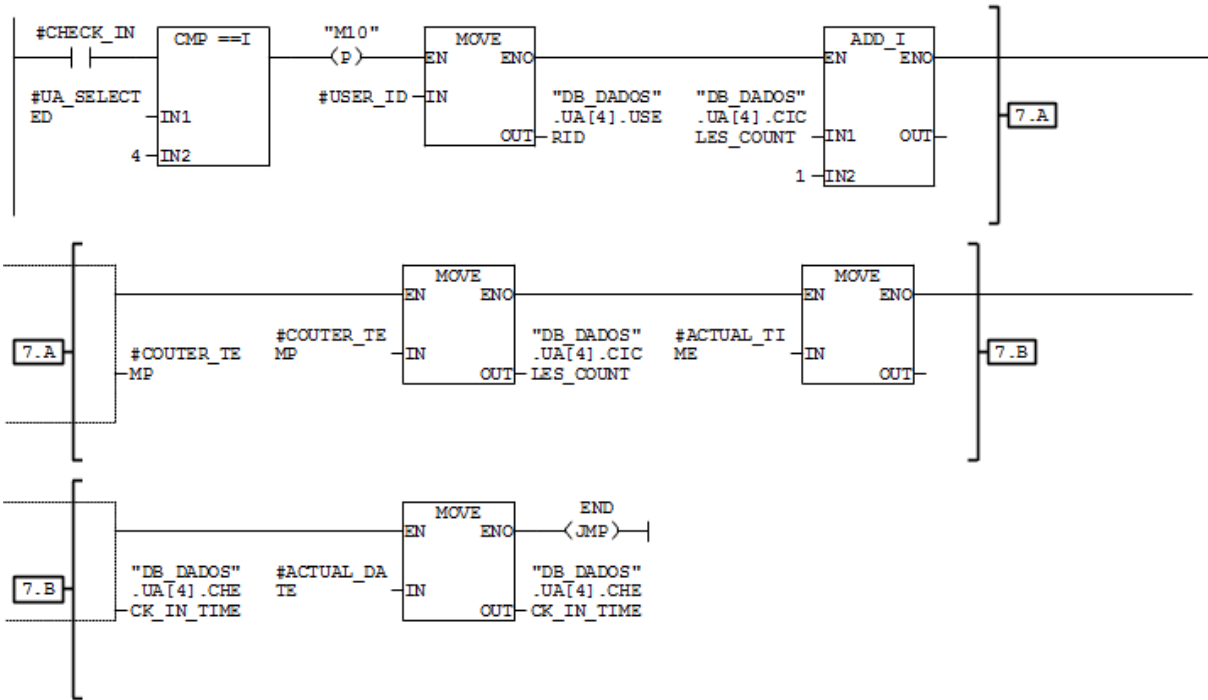

Symbol information

M2.3 M10  
 DB1.DBW32 "DB\_DADOS".UA[4].USERID Identificacao do utilizador registado na UA  
 DB1.DBW34 "DB\_DADOS".UA[4].CICLES\_COUNT Registo do numero de ciclos da UA  
 DB1.DBD36 "DB\_DADOS".UA[4].CHECK\_IN\_TIME hora do check-in

Network: 8 UA 5

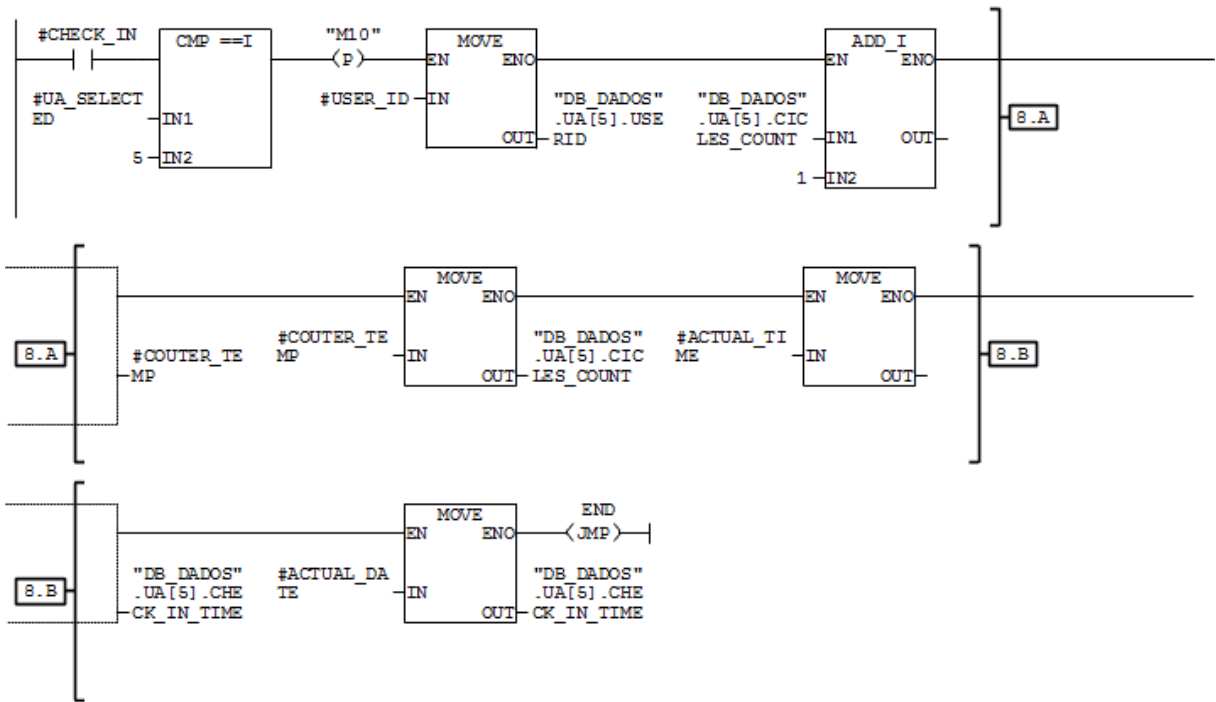

Symbol information

M2.3	M10	
DB1.DEW42	"DB_DADOS".UA[5].USERID	Identificacao do utilizador registado na UA
DB1.DEW44	"DB_DADOS".UA[5].CICLES_COUNT	Registo do numero de ciclos da UA
DB1.DBD46	"DB_DADOS".UA[5].CHECK_IN_TIME	hora do check-in

Network: 9 UA 6

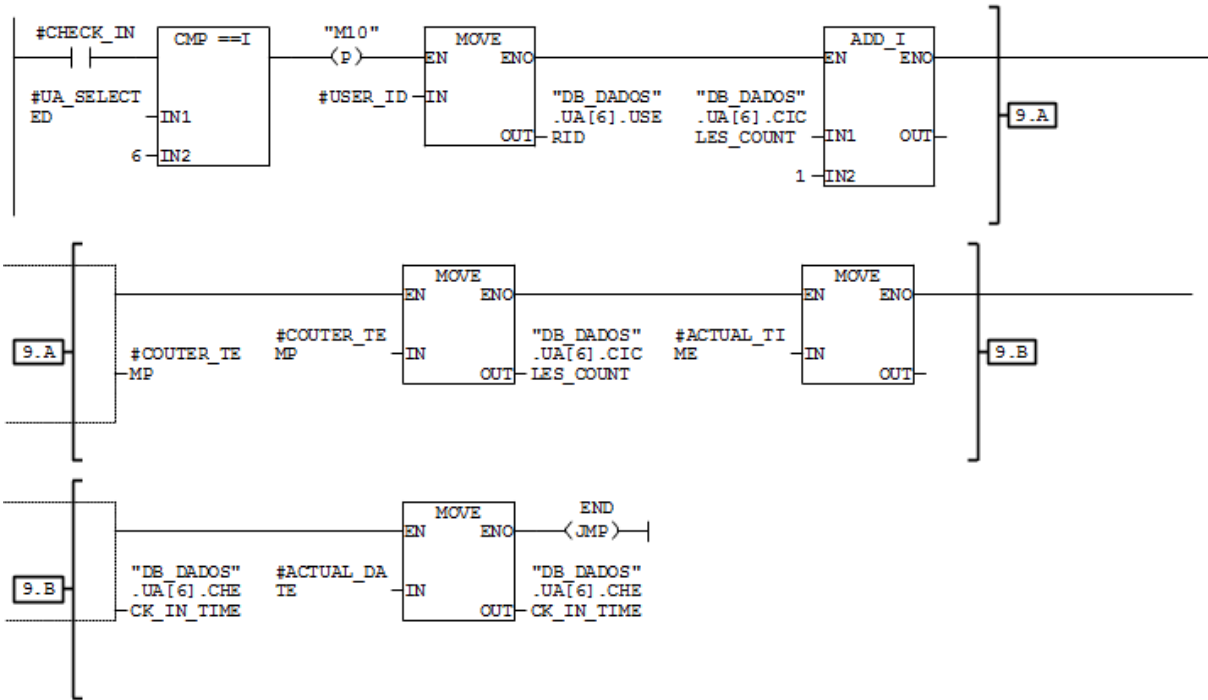

Symbol information

M2.3 M10  
 DB1.DBW52 "DB\_DADOS".UA[6].USERID Identificacao do utilizador registado na UA  
 DB1.DBW54 "DB\_DADOS".UA[6].CICLES\_COUNT Registo do numero de ciclos da UA  
 DB1.DBD56 "DB\_DADOS".UA[6].CHECK\_IN\_TIME hora do check-in

Network: 10 UA 7

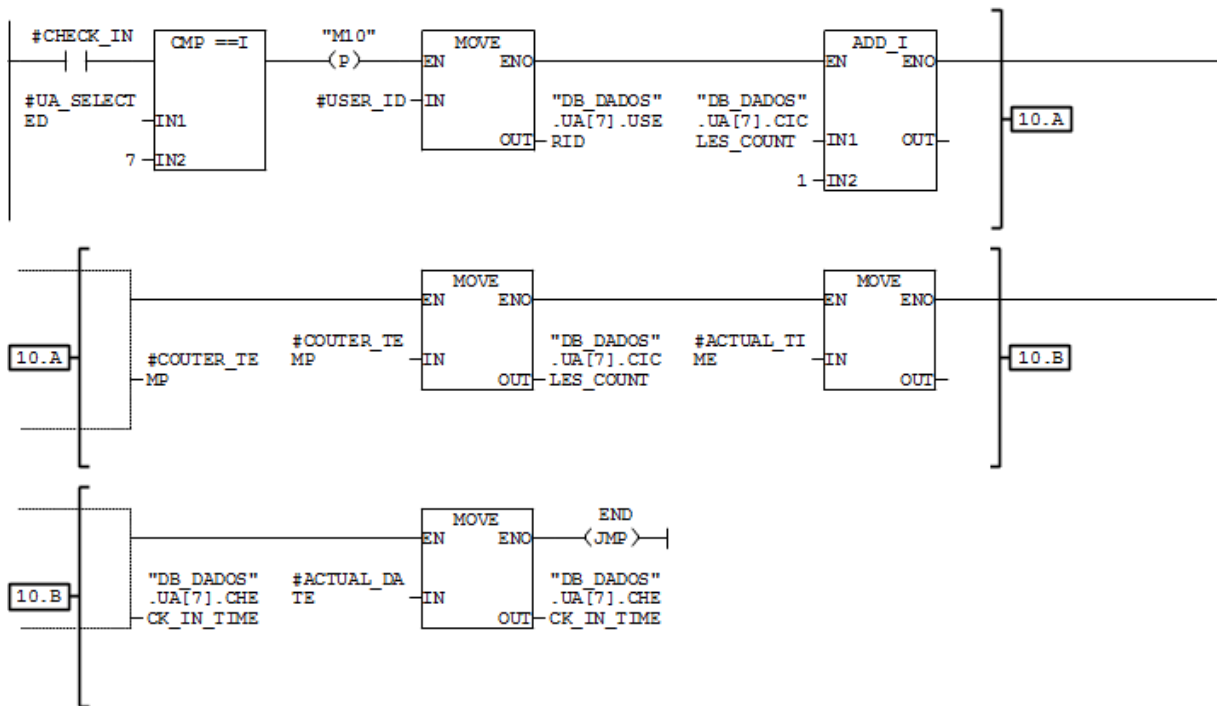

Symbol information

M2.3 M10  
 DB1.DBW62 "DB\_DADOS".UA[7].USERID Identificacao do utilizador registado na UA  
 DB1.DBW64 "DB\_DADOS".UA[7].CICLES\_COUNT Registo do numero de ciclos da UA  
 DB1.DBD66 "DB\_DADOS".UA[7].CHECK\_IN\_TIMEhora do check-in

Network: 11 UA 8

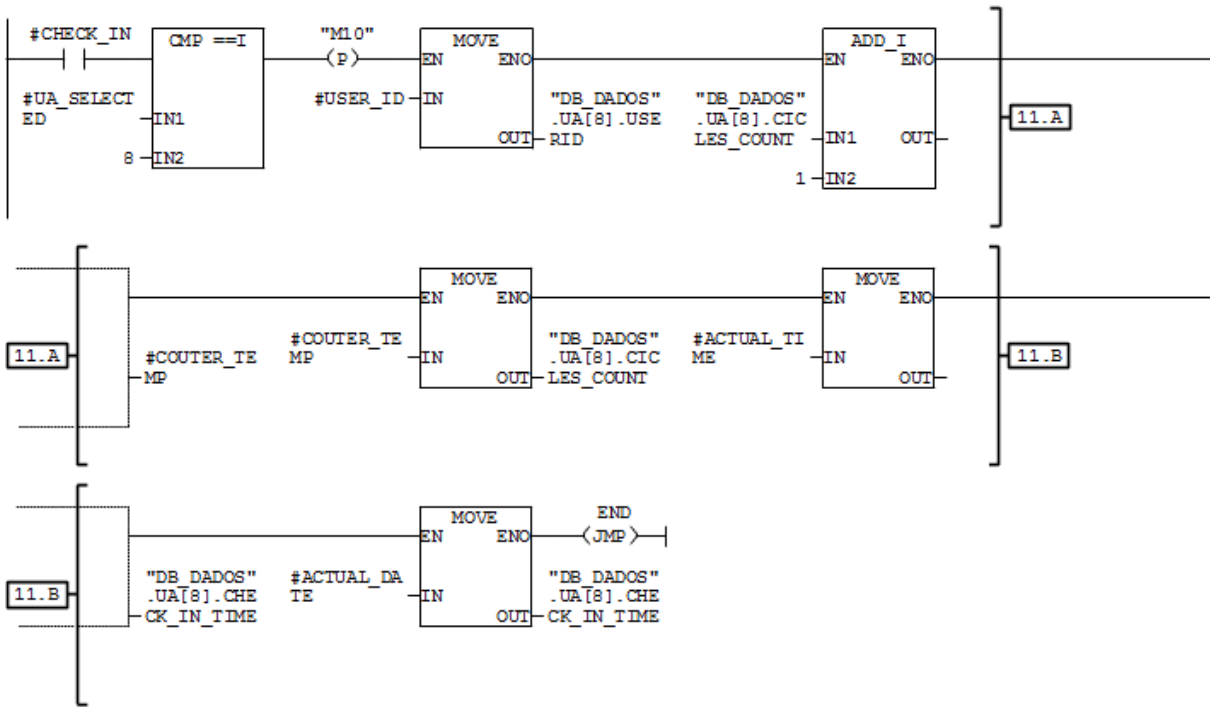

Symbol information

M2.3 M10  
 DB1.DBW72 "DB\_DADOS".UA[8].USERID Identificacao do utilizador registado na UA  
 DB1.DBW74 "DB\_DADOS".UA[8].CICLES\_COUNT Registo do numero de ciclos da UA  
 DB1.DBD76 "DB\_DADOS".UA[8].CHECK\_IN\_TIMEhora do check-in

Network: 12 UA 9

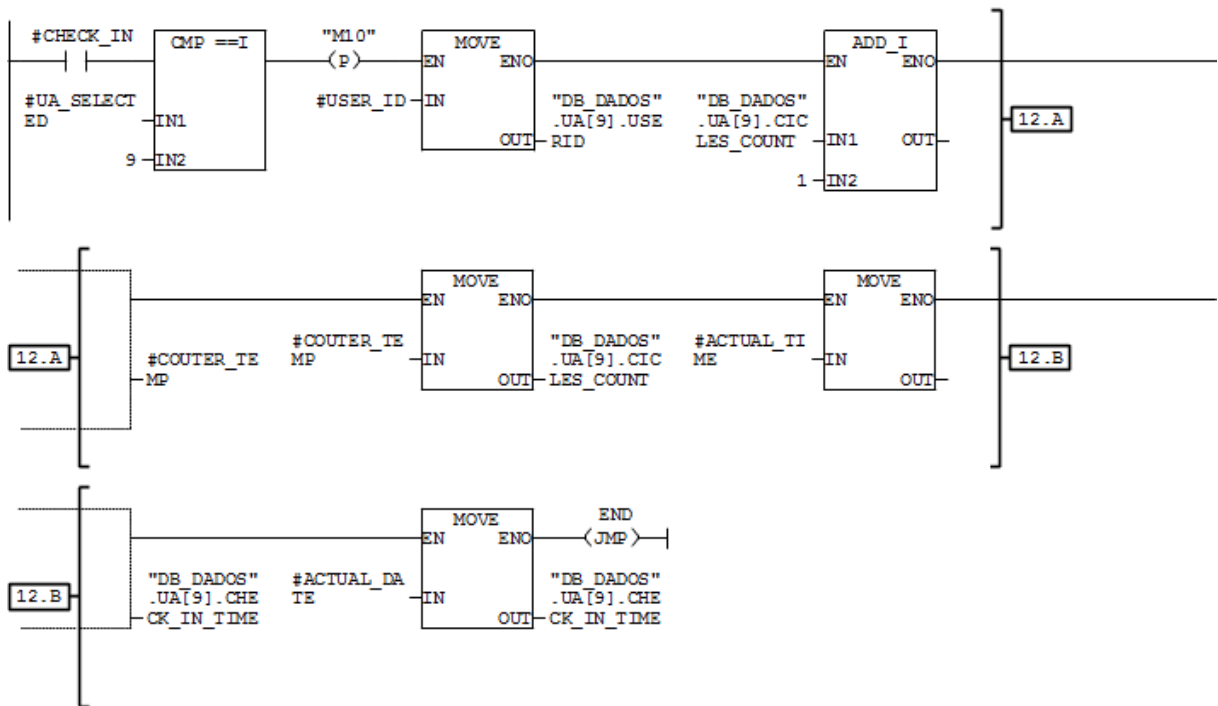

Symbol information

M2.3 M10  
 DB1.DBW82 "DB\_DADOS".UA[9].USERID Identificacao do utilizador registado na UA  
 DB1.DBW84 "DB\_DADOS".UA[9].CICLES\_COUNT Registo do numero de ciclos da UA  
 DB1.DB86 "DB\_DADOS".UA[9].CHECK\_IN\_TIMEhora do check-in

Network: 13 UA 10

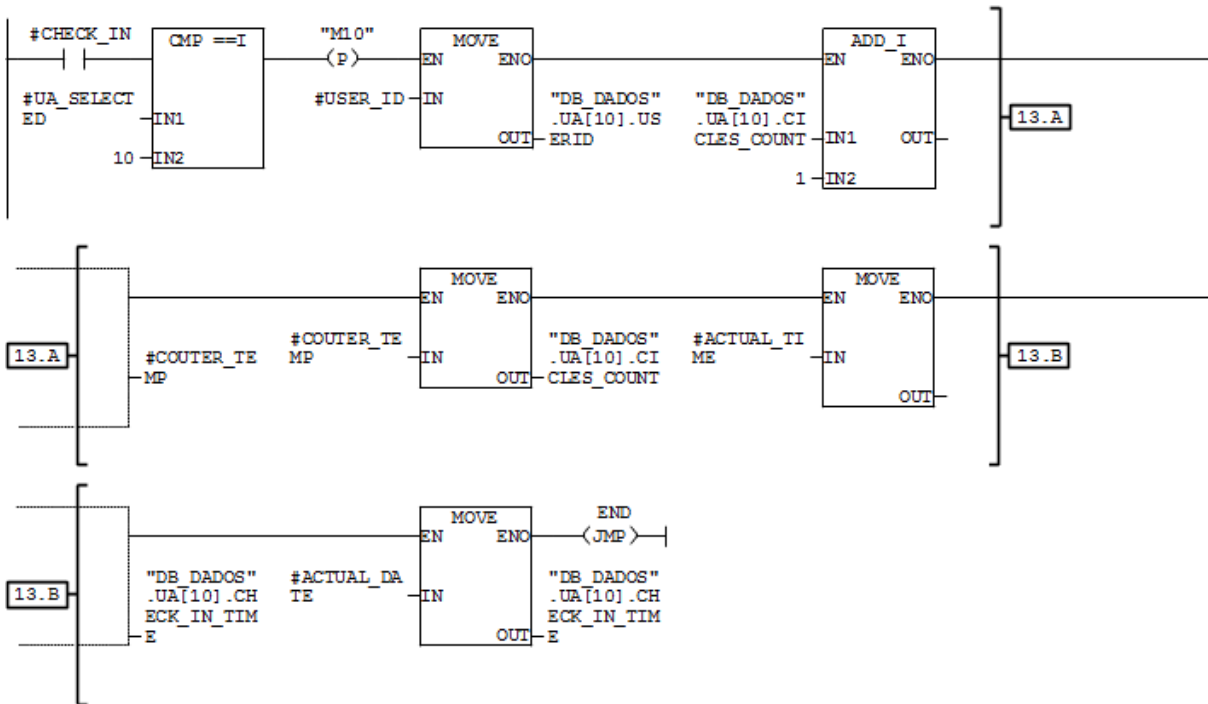

Symbol information

M2.3 M10  
 DB1.DBW92 "DB\_DADOS".UA[10].USERID Identificacao do utilizador registado na UA  
 DB1.DBW94 "DB\_DADOS".UA[10].CICLES\_COUNT Registo do numero de ciclos da UA  
 DB1.DBD96 "DB\_DADOS".UA[10].CHECK\_IN\_TIMEhora do check-in

Network: 14 UA 11

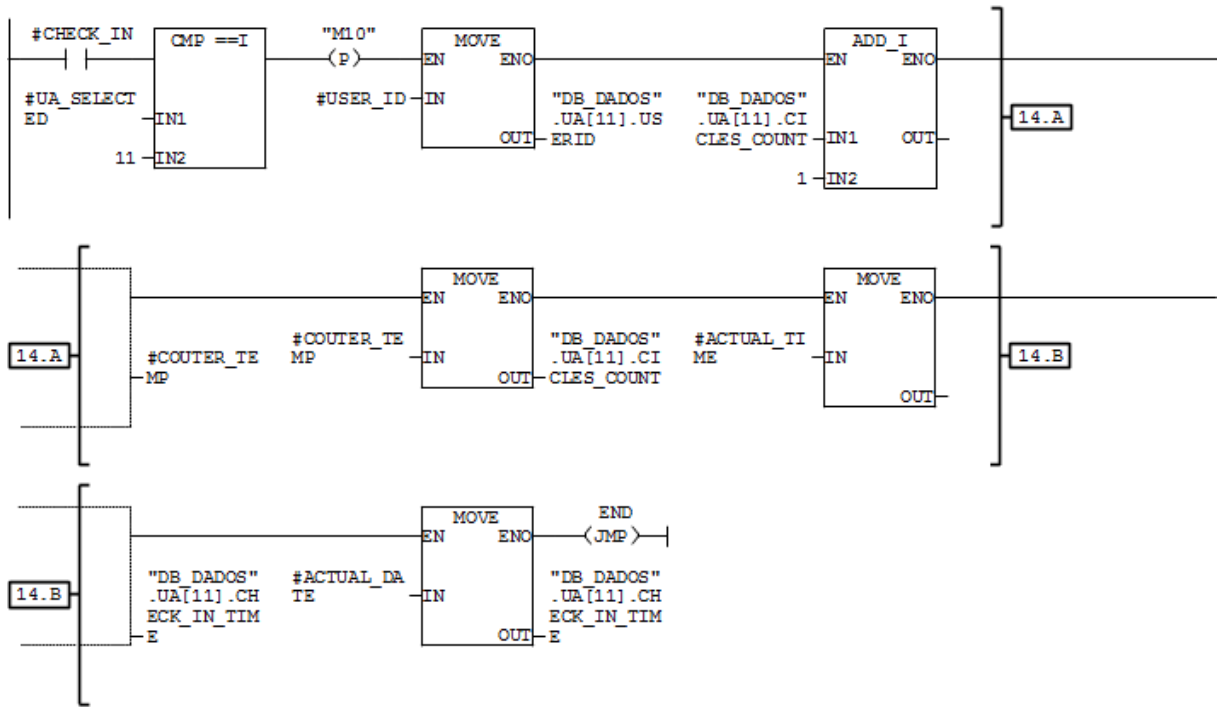

Symbol information

M2.3 M10  
 DB1.DBW102 "DB\_DADOS".UA[11].USERID Identificacao do utilizador registado na UA  
 DB1.DBW104 "DB\_DADOS".UA[11].CICLES\_COUNT Registo do numero de ciclos da UA  
 DB1.DBD106 "DB\_DADOS".UA[11].CHECK\_IN\_TIMEhora do check-in

Network: 15 UA 12

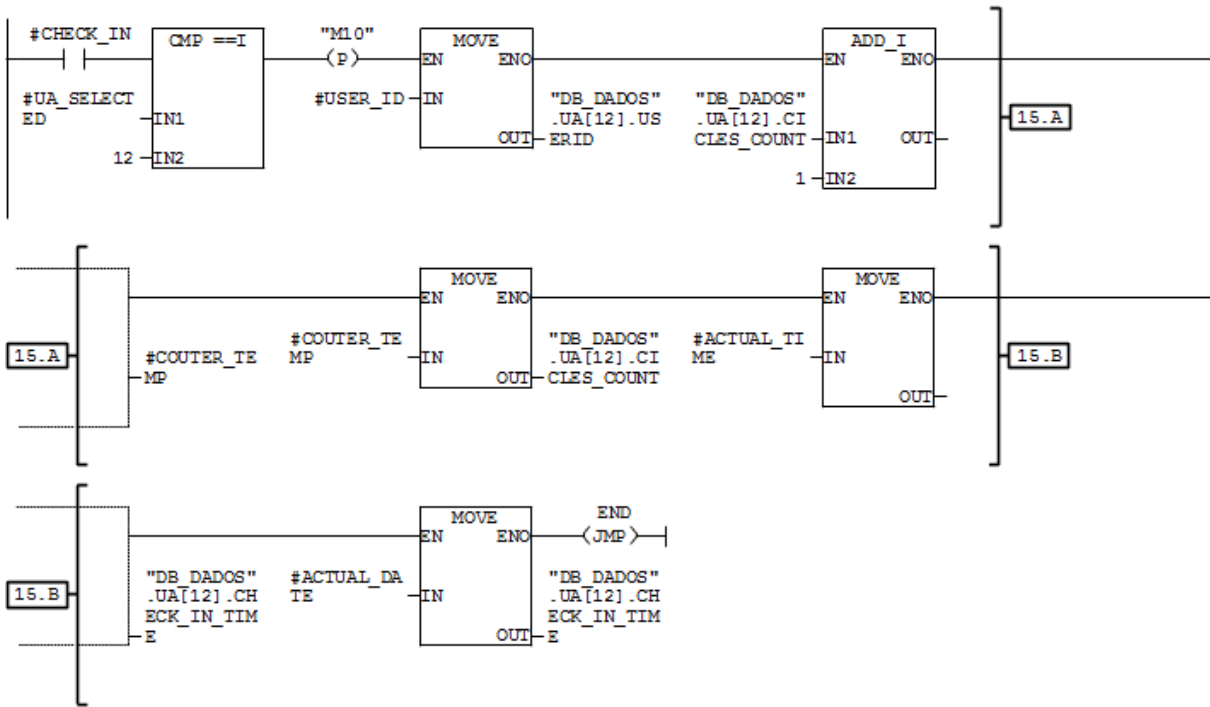

Symbol information

M2.3 M10  
 DB1.DBW112 "DB\_DADOS".UA[12].USERID Identificacao do utilizador registado na UA  
 DB1.DBW114 "DB\_DADOS".UA[12].CICLES\_COUNT Registo do numero de ciclos da UA  
 DB1.DB116 "DB\_DADOS".UA[12].CHECK\_IN\_TIMEhora do check-in

Network: 16 UA 13

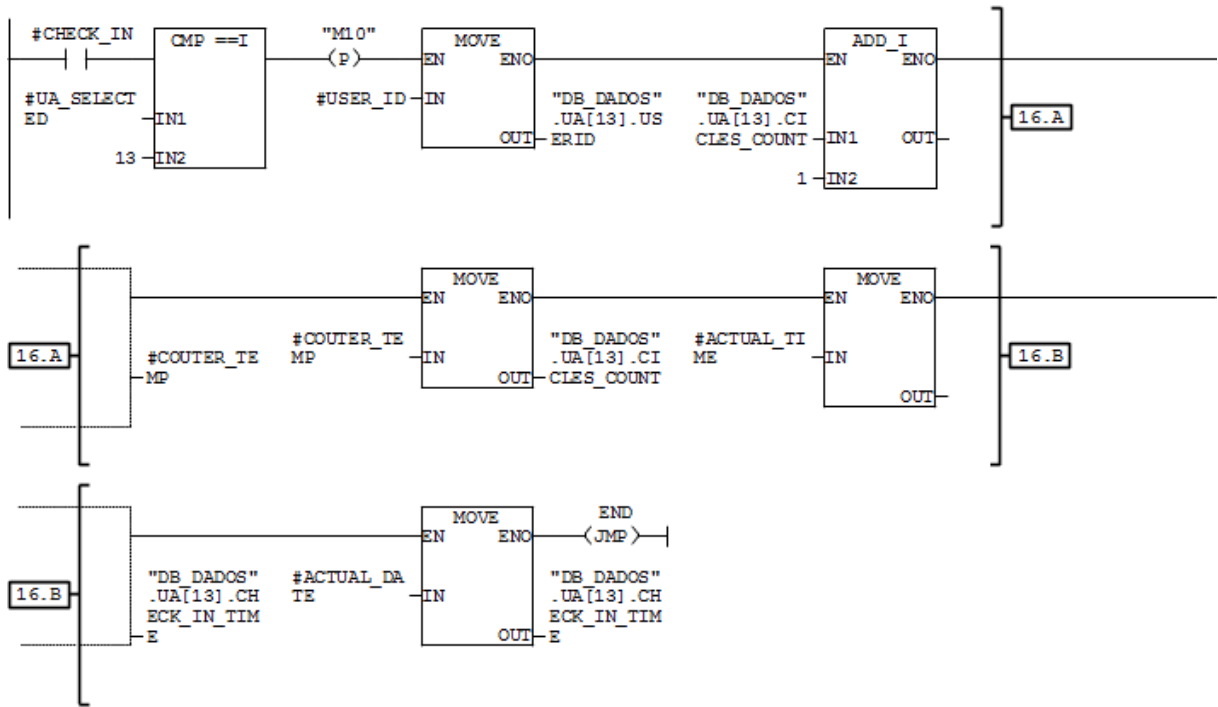

Symbol information

M2.3 M10  
 DB1.DBW122 "DB\_DADOS".UA[13].USERID Identificacao do utilizador registado na UA  
 DB1.DBW124 "DB\_DADOS".UA[13].CICLES\_COUNT Registo do numero de ciclos da UA  
 DB1.DBD126 "DB\_DADOS".UA[13].CHECK\_IN\_TIMEhora do check-in

Network: 17 UA 14

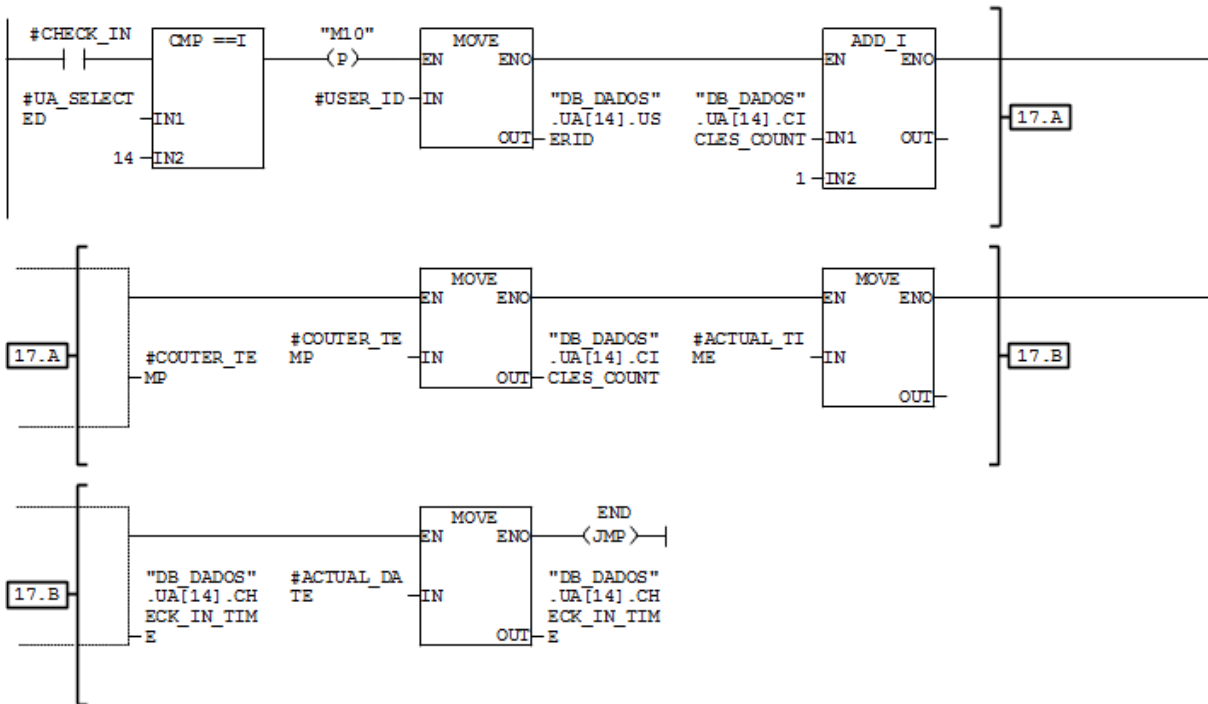

Symbol information

M2.3 M10  
 DB1.DBW132 "DB\_DADOS".UA[14].USERID Identificacao do utilizador registado na UA  
 DB1.DBW134 "DB\_DADOS".UA[14].CICLES\_COUNT Registo do numero de ciclos da UA  
 DB1.DBD136 "DB\_DADOS".UA[14].CHECK\_IN\_TIMEhora do check-in

Network: 18 UA 15

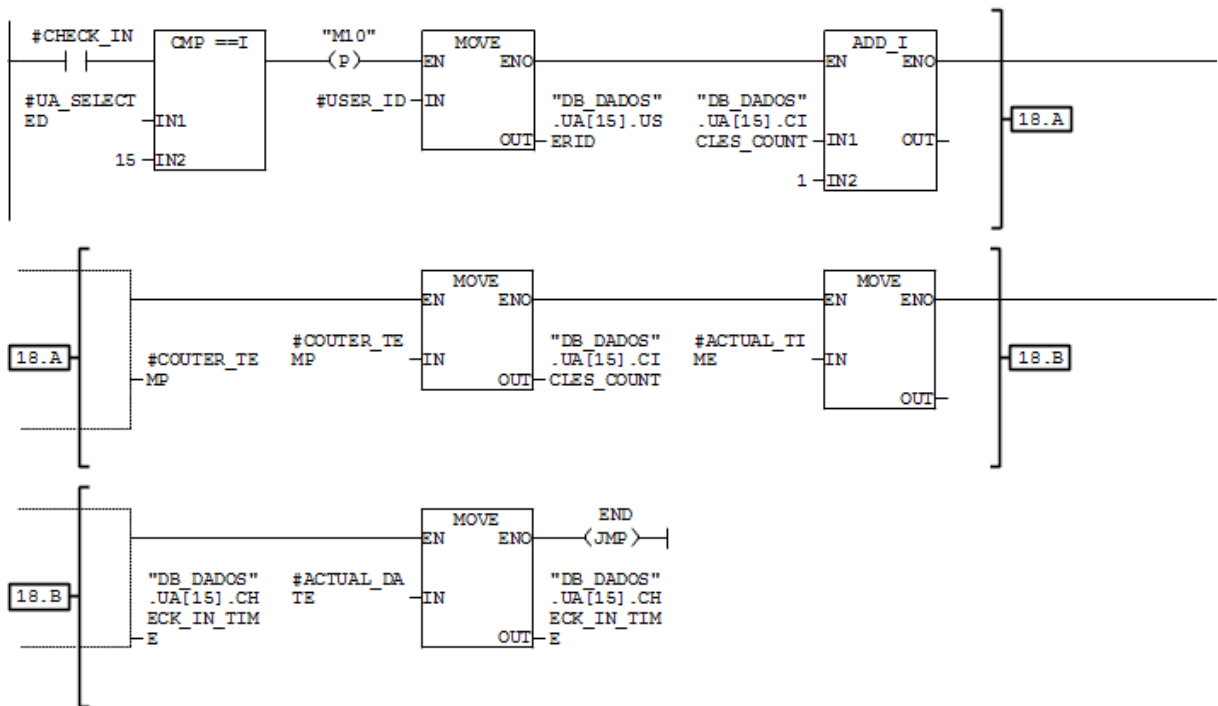

Symbol information

M2.3 M10  
 DB1.DBW142 "DB\_DADOS".UA[15].USERID Identificacao do utilizador registado na UA  
 DB1.DBW144 "DB\_DADOS".UA[15].CICLES COUNT Registo do numero de ciclos da UA  
 DB1.DBD146 "DB\_DADOS".UA[15].CHECK\_IN\_TIMEhora do check-in

Network: 19 UA 16

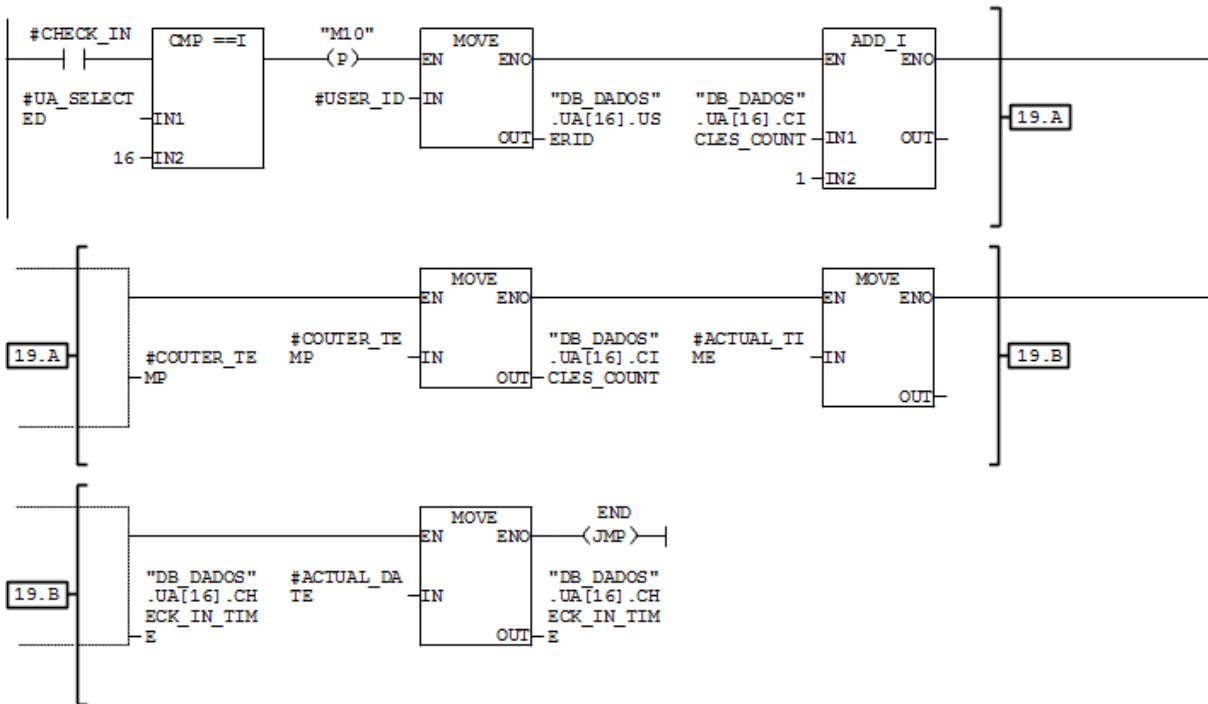

Symbol information

M2.3 M10  
 DB1.DBW152 "DB\_DADOS".UA[16].USERID Identificacao do utilizador registado na UA  
 DB1.DBW154 "DB\_DADOS".UA[16].CICLES\_COUNT Registo do numero de ciclos da UA  
 DB1.DBD156 "DB\_DADOS".UA[16].CHECK\_IN\_TIMEhora do check-in

Network: 20 UA 17

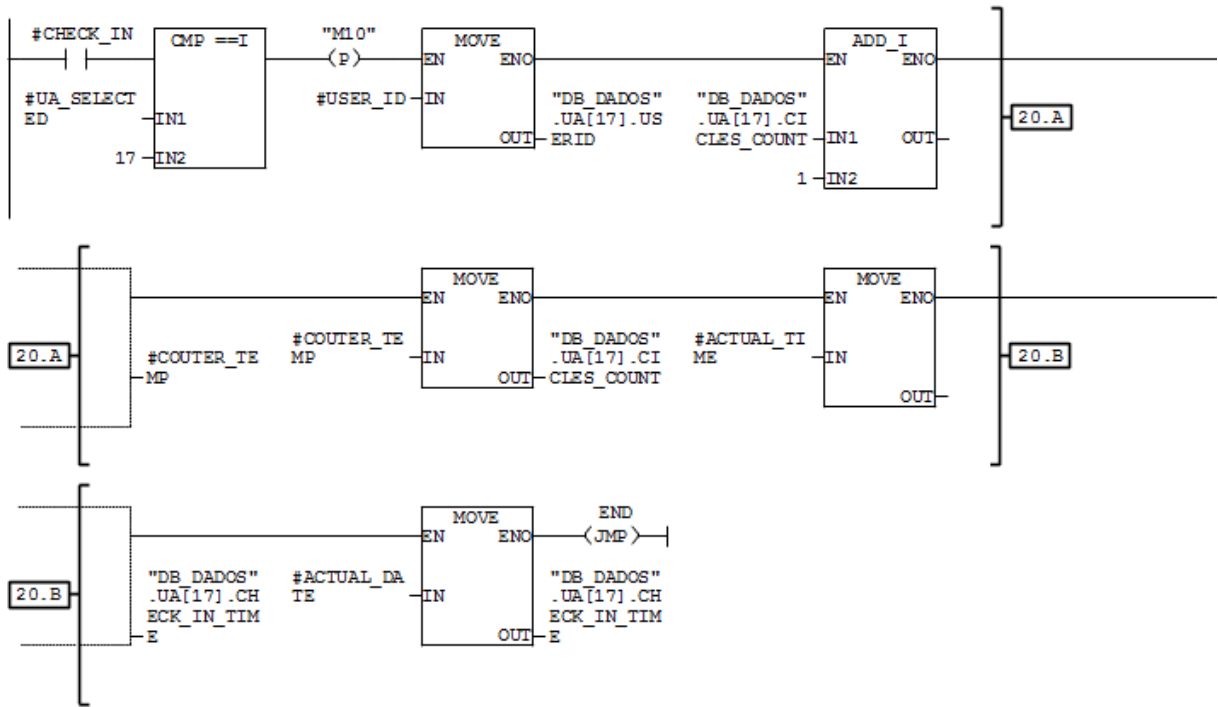

Symbol information

M2.3 M10  
 DB1.DBW162 "DB\_DADOS".UA[17].USERID Identificacao do utilizador registado na UA  
 DB1.DBW164 "DB\_DADOS".UA[17].CICLES\_COUNT Registo do numero de ciclos da UA  
 DB1.DBD166 "DB\_DADOS".UA[17].CHECK\_IN\_TIMEhora do check-in

Network: 21 UA 18

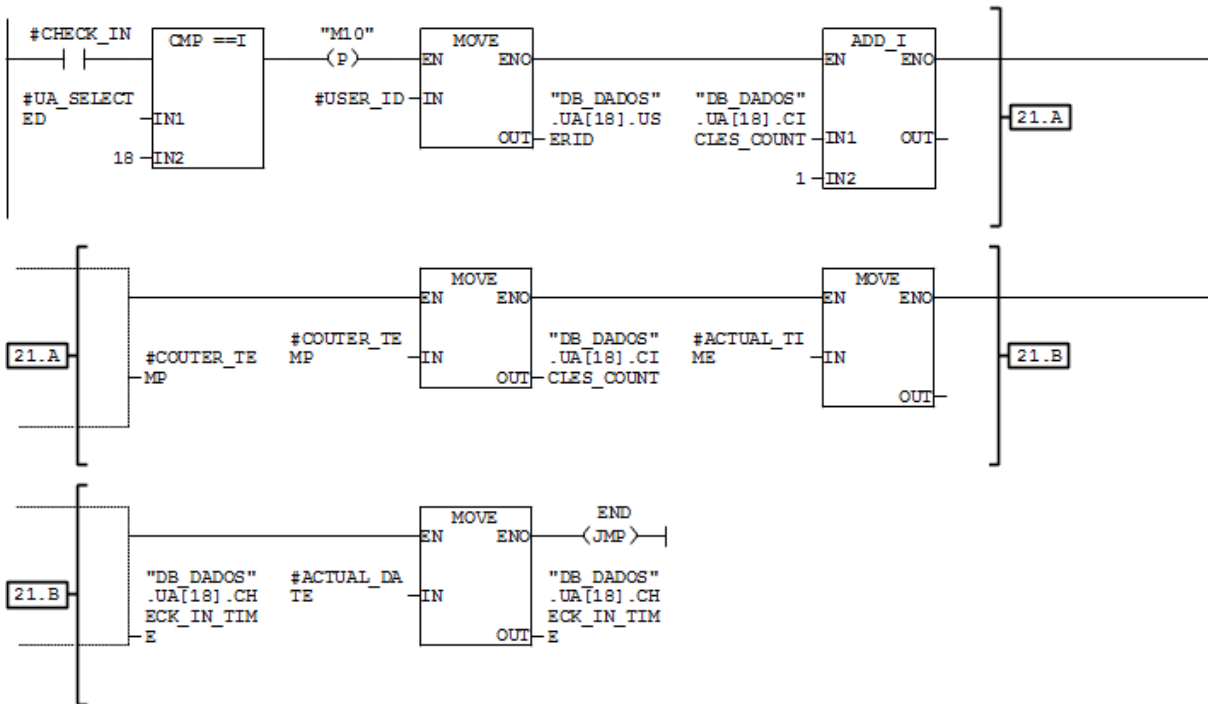

Symbol information

M2.3 M10  
 DB1.DBW172 "DB\_DADOS".UA[18].USERID Identificacao do utilizador registado na UA  
 DB1.DBW174 "DB\_DADOS".UA[18].CICLES\_COUNT Registo do numero de ciclos da UA  
 DB1.DB176 "DB\_DADOS".UA[18].CHECK\_IN\_TIMEhora do check-in

Network: 22 UA 19

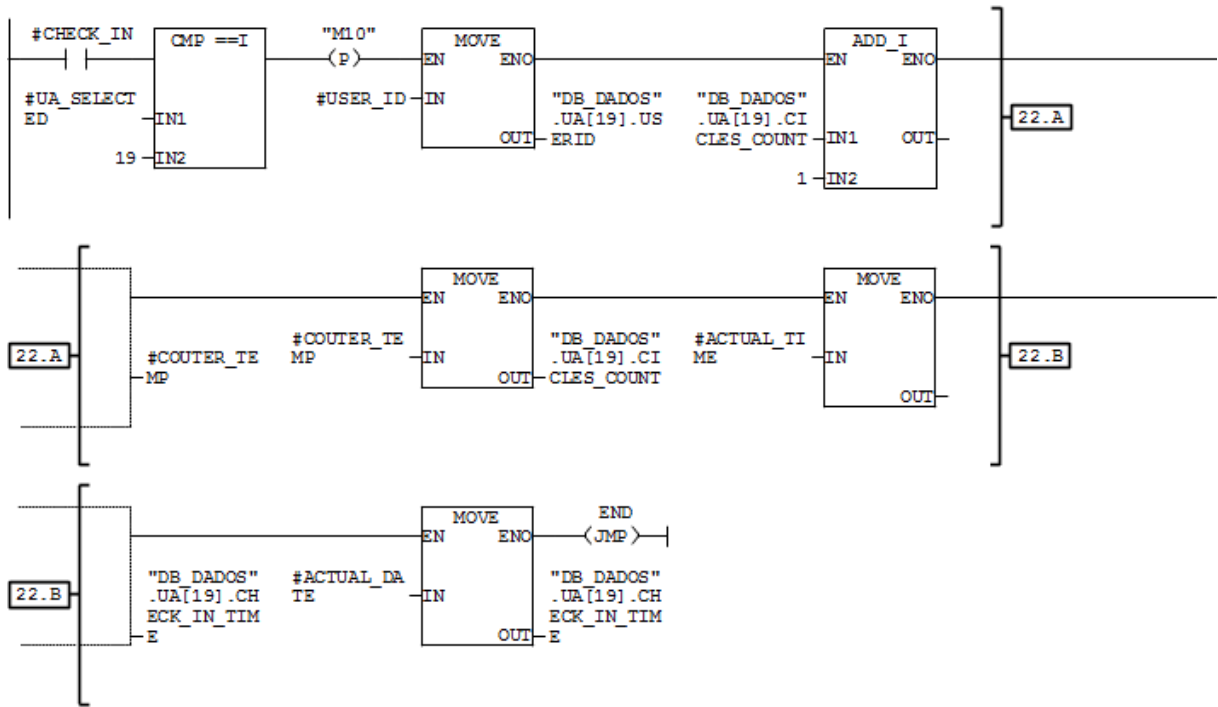

Symbol information

M2.3 M10  
 DB1.DBW182 "DB\_DADOS".UA[19].USERID Identificacao do utilizador registado na UA  
 DB1.DBW184 "DB\_DADOS".UA[19].CICLES\_COUNT Registo do numero de ciclos da UA  
 DB1.DBD186 "DB\_DADOS".UA[19].CHECK\_IN\_TIMEhora do check-in

Network: 23 UA 20

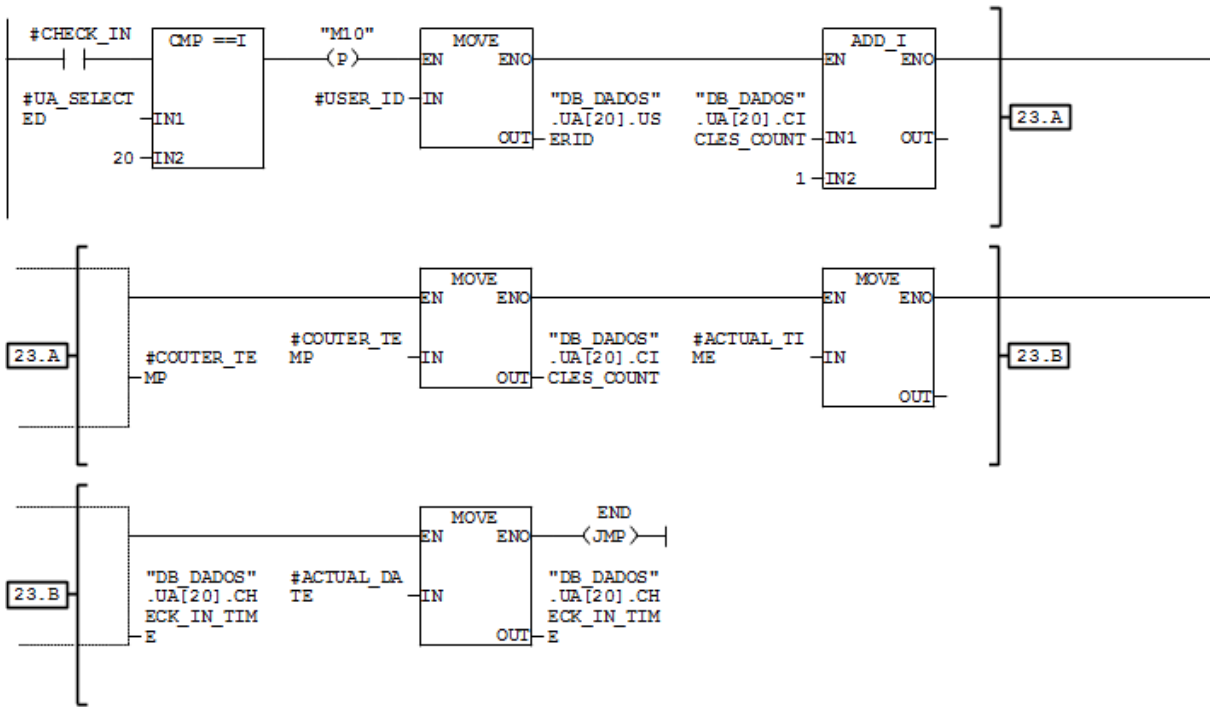

Symbol information

M2.3 M10  
 DB1.DBW192 "DB\_DADOS".UA[20].USERID Identificacao do utilizador registado na UA  
 DB1.DBW194 "DB\_DADOS".UA[20].CICLES\_COUNT Registo do numero de ciclos da UA  
 DB1.DB196 "DB\_DADOS".UA[20].CHECK\_IN\_TIMEhora do check-in

Network: 24 UA 21

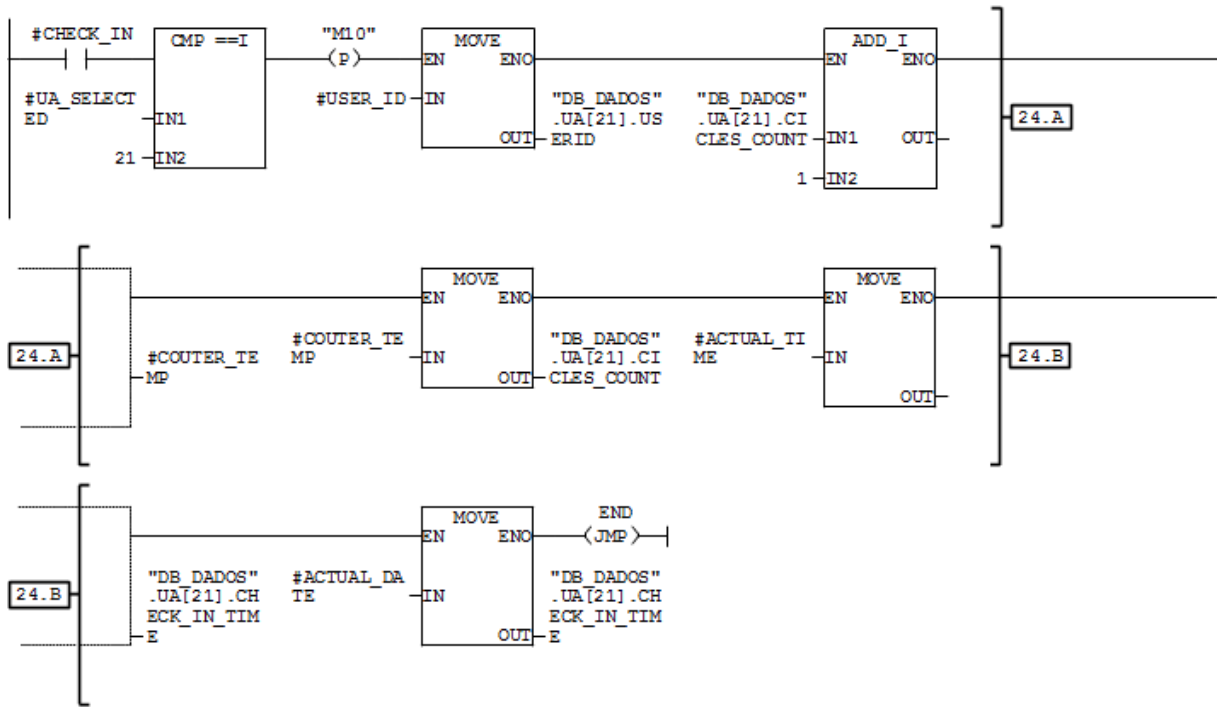

Symbol information

M2.3 M10  
 DB1.DBW202 "DB\_DADOS".UA[21].USERID Identificacao do utilizador registado na UA  
 DB1.DBW204 "DB\_DADOS".UA[21].CICLES\_COUNT Registo do numero de ciclos da UA  
 DB1.DBD206 "DB\_DADOS".UA[21].CHECK\_IN\_TIMEhora do check-in

Network: 25 UA 22

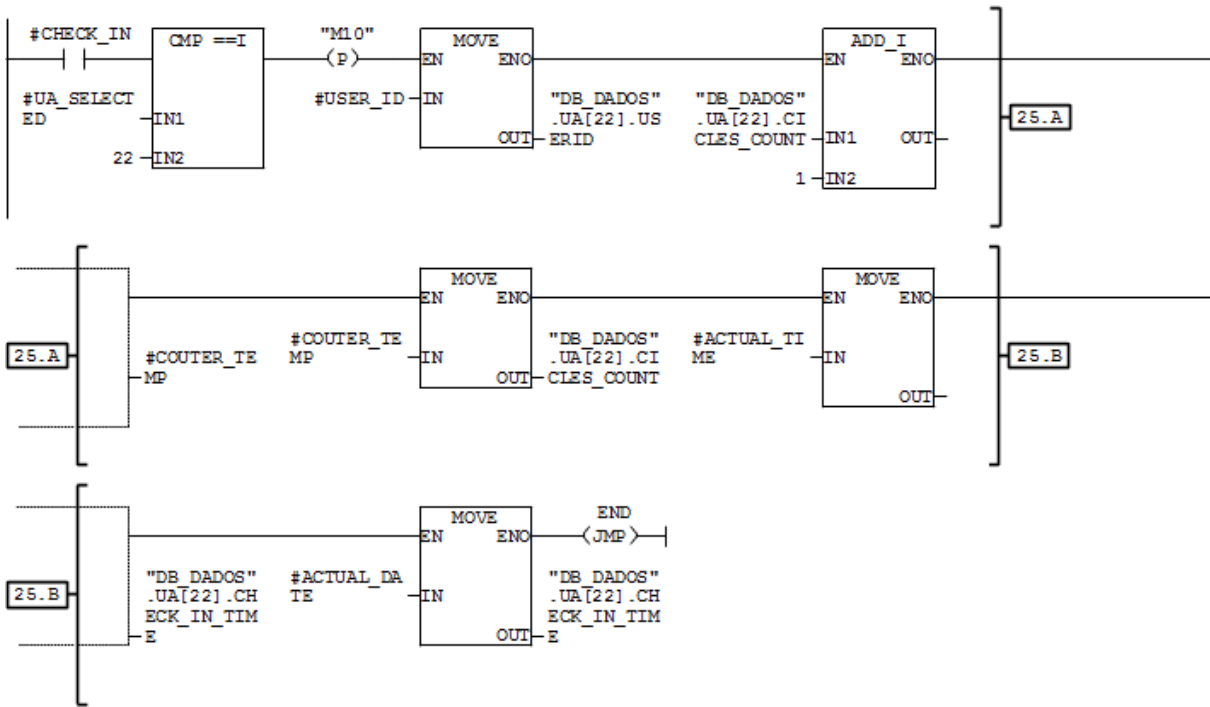

Symbol information

M2.3 M10  
 DB1.DBW212 "DB\_DADOS".UA[22].USERID Identificacao do utilizador registado na UA  
 DB1.DBW214 "DB\_DADOS".UA[22].CICLES\_COUNT Registo do numero de ciclos da UA  
 DB1.DBD216 "DB\_DADOS".UA[22].CHECK\_IN\_TIMEhora do check-in

Network: 26 UA 23

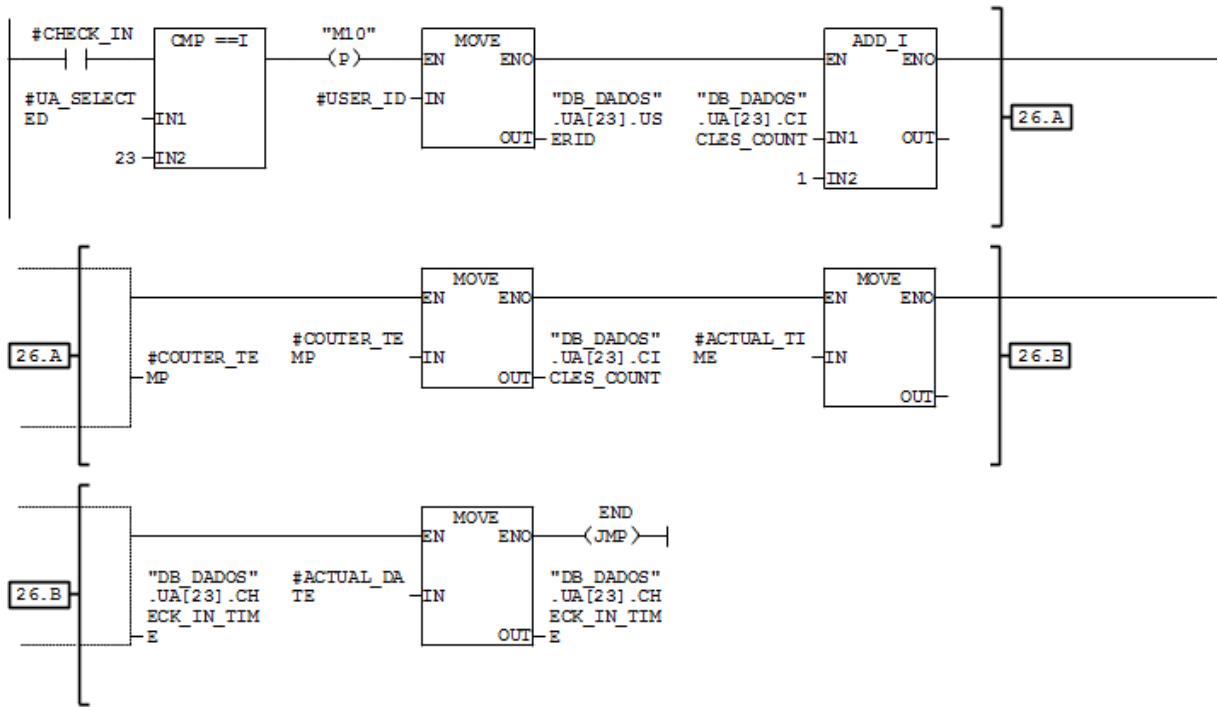

Symbol information

M2.3 M10  
 DB1.DBW222 "DB\_DADOS".UA[23].USERID Identificacao do utilizador registado na UA  
 DB1.DBW224 "DB\_DADOS".UA[23].CICLES\_COUNT Registo do numero de ciclos da UA  
 DB1.DBD226 "DB\_DADOS".UA[23].CHECK\_IN\_TIMEhora do check-in

Network: 27 UA 24

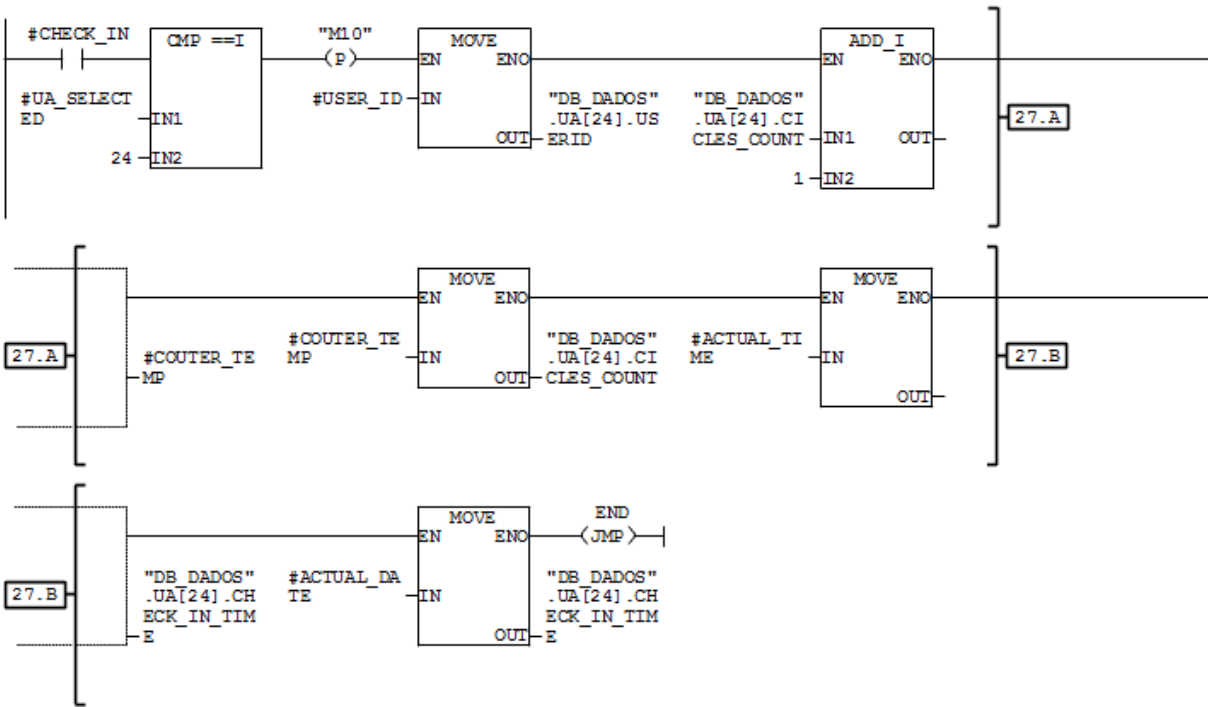

Symbol information

M2.3 M10  
 DB1.DBW232 "DB\_DADOS".UA[24].USERID Identificacao do utilizador registado na UA  
 DB1.DBW234 "DB\_DADOS".UA[24].CICLES\_COUNT Registo do numero de ciclos da UA  
 DB1.DBD236 "DB\_DADOS".UA[24].CHECK\_IN\_TIMEhora do check-in

Network: 28 UA 1

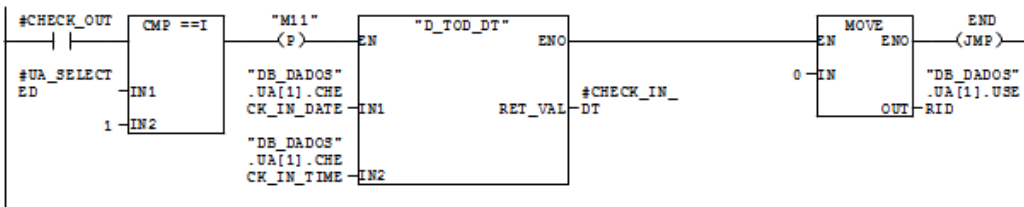

Symbol information

M2.4 M11  
 FC13 D TOD\_DT Date and TOD to DT  
 DB1.DBW10 "DB\_DADOS".UA[1].CHECK\_IN\_DATEdata do check-in  
 DB1.DBD6 "DB\_DADOS".UA[1].CHECK\_IN\_TIMEhora do check-in  
 DB1.DBW2 "DB\_DADOS".UA[1].USERID Identificacao do utilizador registado na UA

Network: 29 UA 2

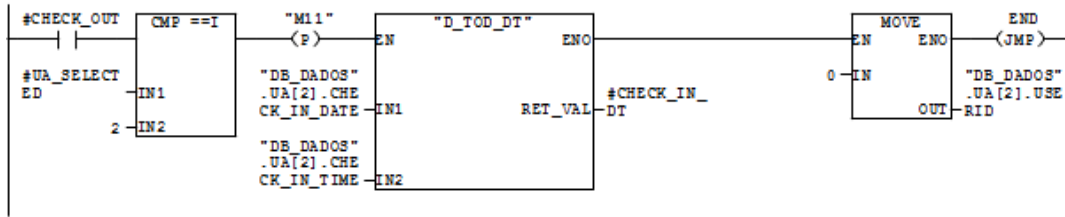

Symbol information

M2.4 M11  
 FC13 D TOD DT Date and TOD to DT  
 DB1.DBW20 "DB\_DADOS".UA[2].CHECK\_IN\_DATE data do check-in  
 DB1.DBD16 "DB\_DADOS".UA[2].CHECK\_IN\_TIME hora do check-in  
 DB1.DBW12 "DB\_DADOS".UA[2].USERID Identificacao do utilizador registado na UA

Network: 30 UA 3

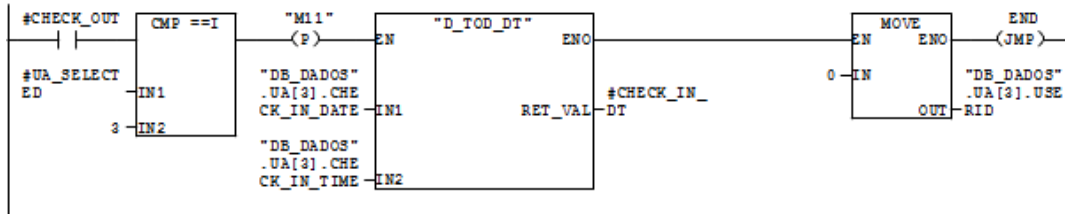

Symbol information

M2.4 M11  
 FC13 D TOD DT Date and TOD to DT  
 DB1.DBW30 "DB\_DADOS".UA[3].CHECK\_IN\_DATE data do check-in  
 DB1.DBD26 "DB\_DADOS".UA[3].CHECK\_IN\_TIME hora do check-in  
 DB1.DBW22 "DB\_DADOS".UA[3].USERID Identificacao do utilizador registado na UA

Network: 31 UA 4

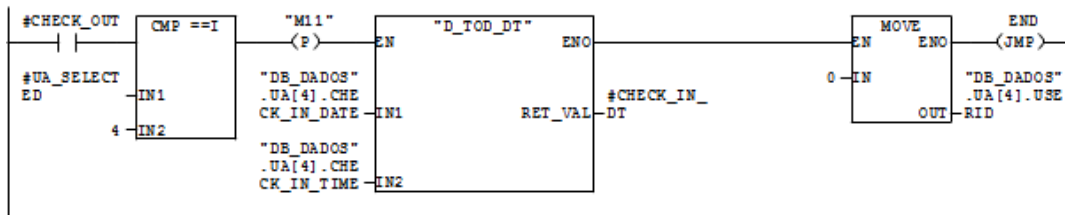

Symbol information

M2.4 M11  
 FC13 D TOD DT Date and TOD to DT  
 DB1.DBW40 "DB\_DADOS".UA[4].CHECK\_IN\_DATE data do check-in  
 DB1.DBD36 "DB\_DADOS".UA[4].CHECK\_IN\_TIME hora do check-in  
 DB1.DBW32 "DB\_DADOS".UA[4].USERID Identificacao do utilizador registado na UA

Network: 32 UA 5

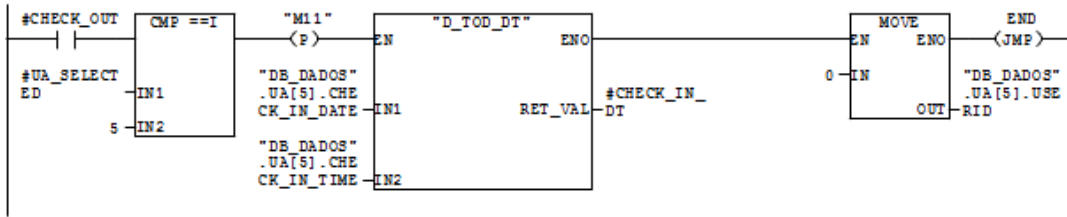

Symbol information

M2.4 M11  
 FC13 D TOD DT Date and TOD to DT  
 DB1.DBW50 "DB\_DADOS".UA[5].CHECK\_IN\_DATE data do check-in  
 DB1.DBD46 "DB\_DADOS".UA[5].CHECK\_IN\_TIME hora do check-in  
 DB1.DBW42 "DB\_DADOS".UA[5].USERID Identificacao do utilizador registado na UA

Network: 33 UA 6

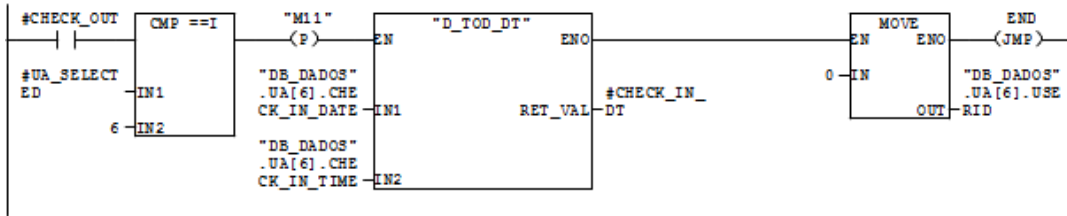

Symbol information

M2.4 M11  
 FC13 D TOD DT Date and TOD to DT  
 DB1.DBW60 "DB\_DADOS".UA[6].CHECK\_IN\_DATE data do check-in  
 DB1.DBD66 "DB\_DADOS".UA[6].CHECK\_IN\_TIME hora do check-in  
 DB1.DBW52 "DB\_DADOS".UA[6].USERID Identificacao do utilizador registado na UA

Network: 34 UA 7

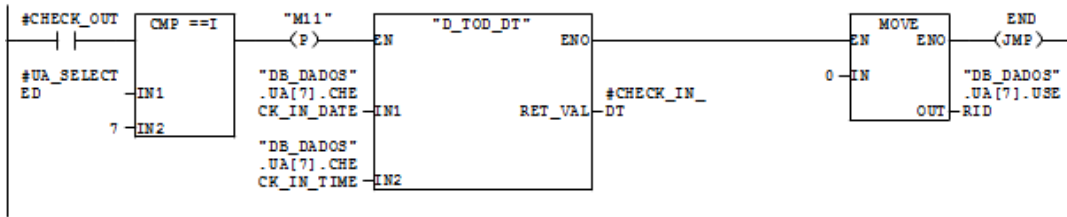

Symbol information

M2.4 M11  
 FC13 D TOD DT Date and TOD to DT  
 DB1.DBW70 "DB\_DADOS".UA[7].CHECK\_IN\_DATE data do check-in  
 DB1.DBD66 "DB\_DADOS".UA[7].CHECK\_IN\_TIME hora do check-in  
 DB1.DBW62 "DB\_DADOS".UA[7].USERID Identificacao do utilizador registado na UA

Network: 35 UA 8

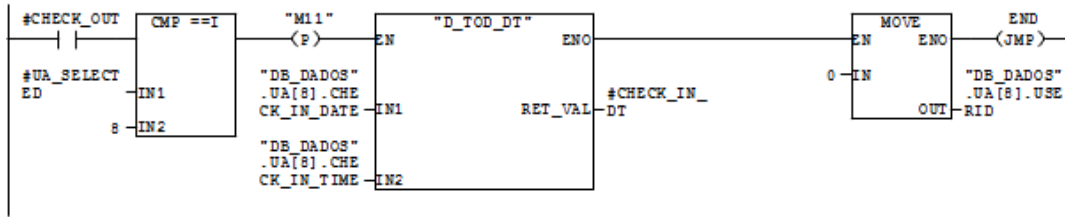

Symbol information

M2.4 M11  
 FC13 D\_TOD\_DT Date and TOD to DT  
 DB1.DBW80 "DB\_DADOS".UA[8].CHECK\_IN\_DATE data do check-in  
 DB1.DBD76 "DB\_DADOS".UA[8].CHECK\_IN\_TIME hora do check-in  
 DB1.DBW72 "DB\_DADOS".UA[8].USERID Identificacao do utilizador registado na UA

Network: 36 UA 9

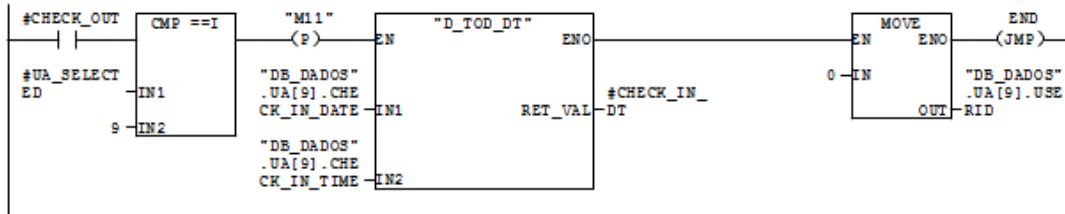

Symbol information

M2.4 M11  
 FC13 D\_TOD\_DT Date and TOD to DT  
 DB1.DBW90 "DB\_DADOS".UA[9].CHECK\_IN\_DATE data do check-in  
 DB1.DBD86 "DB\_DADOS".UA[9].CHECK\_IN\_TIME hora do check-in  
 DB1.DBW82 "DB\_DADOS".UA[9].USERID Identificacao do utilizador registado na UA

Network: 37 UA 10

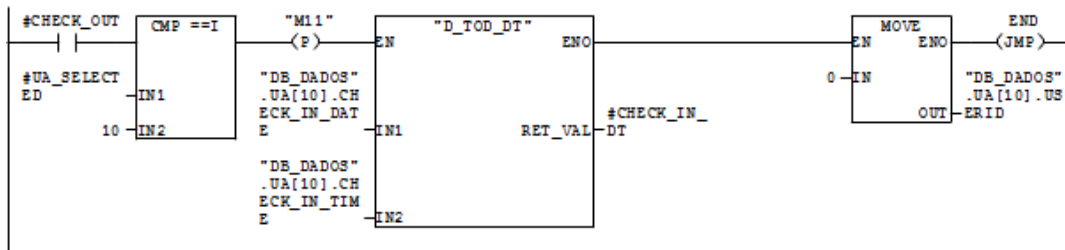

Symbol information

M2.4 M11  
 FC13 D\_TOD\_DT Date and TOD to DT  
 DB1.DBW100 "DB\_DADOS".UA[10].CHECK\_IN\_DATE data do check-in  
 DB1.DBD96 "DB\_DADOS".UA[10].CHECK\_IN\_TIME hora do check-in  
 DB1.DBW92 "DB\_DADOS".UA[10].USERID Identificacao do utilizador registado na UA

Network: 38 UA 11

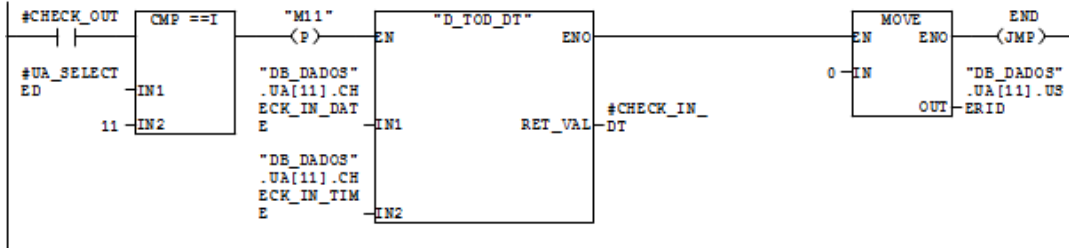

Symbol information

M2.4 M11  
 FC13 D TOD DT Date and TOD to DT  
 DB1.DBW110 "DB\_DADOS".UA[11].CHECK\_IN\_DATE data do check-in  
 DB1.DBD106 "DB\_DADOS".UA[11].CHECK\_IN\_TIME hora do check-in  
 DB1.DBW102 "DB\_DADOS".UA[11].USERID Identificacao do utilizador registado na UA

Network: 39 UA 12

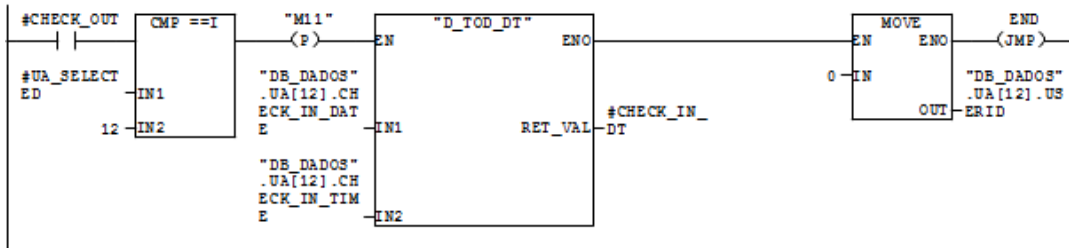

Symbol information

M2.4 M11  
 FC13 D TOD DT Date and TOD to DT  
 DB1.DBW120 "DB\_DADOS".UA[12].CHECK\_IN\_DATE data do check-in  
 DB1.DBD116 "DB\_DADOS".UA[12].CHECK\_IN\_TIME hora do check-in  
 DB1.DBW112 "DB\_DADOS".UA[12].USERID Identificacao do utilizador registado na UA

Network: 40 UA 13

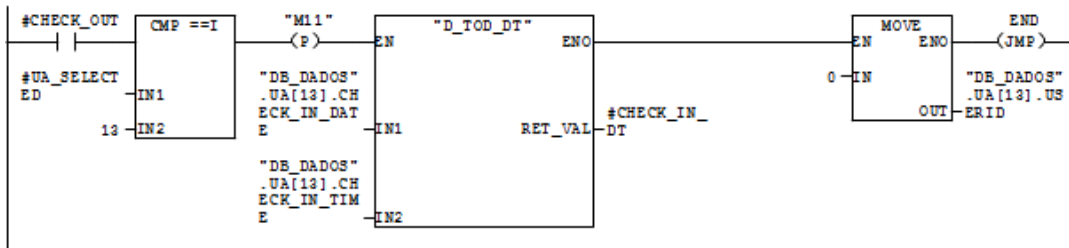

Symbol information

M2.4 M11  
 FC13 D TOD DT Date and TOD to DT  
 DB1.DBW130 "DB\_DADOS".UA[13].CHECK\_IN\_DATE data do check-in  
 DB1.DBD126 "DB\_DADOS".UA[13].CHECK\_IN\_TIME hora do check-in  
 DB1.DBW122 "DB\_DADOS".UA[13].USERID Identificacao do utilizador registado na UA

Network: 41 UA 14

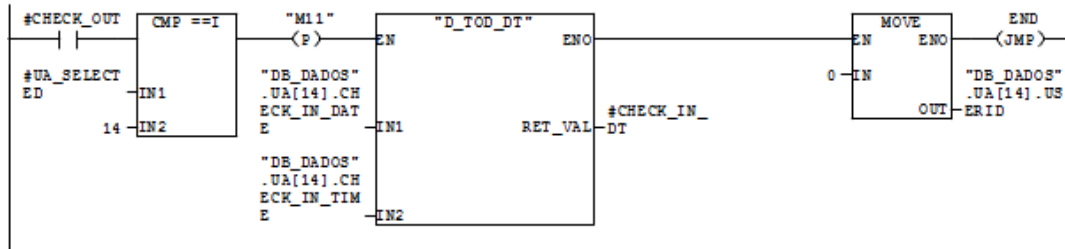

Symbol information

M2.4 M11  
 FC13 D TOD DT Date and TOD to DT  
 DB1.DBW140 "DB\_DADOS".UA[14].CHECK\_IN\_DATE data do check-in  
 DB1.DBD136 "DB\_DADOS".UA[14].CHECK\_IN\_TIME hora do check-in  
 DB1.DBW132 "DB\_DADOS".UA[14].USERID Identificacao do utilizador registado na UA

Network: 42 UA 15

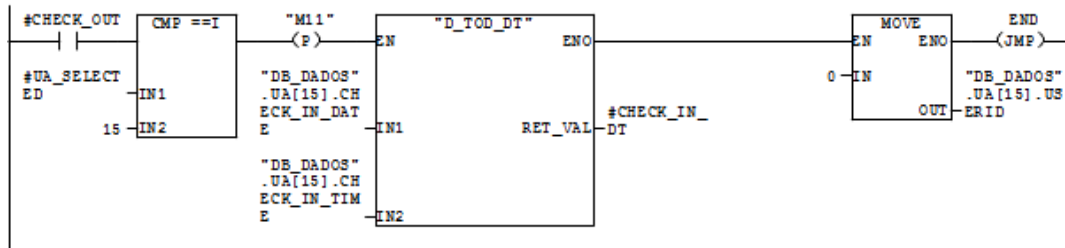

Symbol information

M2.4 M11  
 FC13 D TOD DT Date and TOD to DT  
 DB1.DBW150 "DB\_DADOS".UA[15].CHECK\_IN\_DATE data do check-in  
 DB1.DBD146 "DB\_DADOS".UA[15].CHECK\_IN\_TIME hora do check-in  
 DB1.DBW142 "DB\_DADOS".UA[15].USERID Identificacao do utilizador registado na UA

Network: 43 UA 16

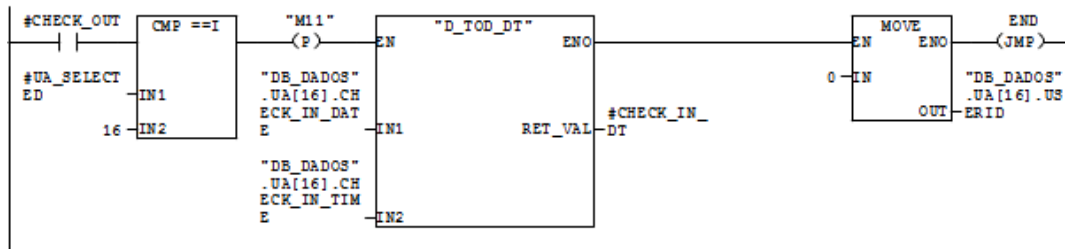

Symbol information

M2.4 M11  
 FC13 D TOD DT Date and TOD to DT  
 DB1.DBW160 "DB\_DADOS".UA[16].CHECK\_IN\_DATE data do check-in  
 DB1.DBD156 "DB\_DADOS".UA[16].CHECK\_IN\_TIME hora do check-in  
 DB1.DBW152 "DB\_DADOS".UA[16].USERID Identificacao do utilizador registado na UA

Network: 44 UA 17

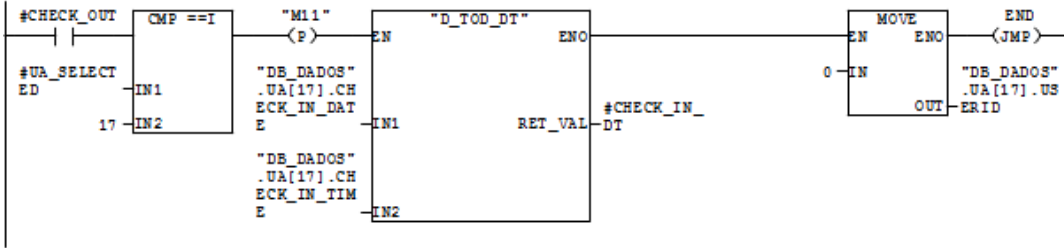

Symbol information

M2.4 M11  
 FC13 D TOD DT Date and TOD to DT  
 DB1.DBW170 "DB\_DADOS".UA[17].CHECK\_IN\_DATEdata do check-in  
 DB1.DB166 "DB\_DADOS".UA[17].CHECK\_IN\_TIMEhora do check-in  
 DB1.DBW162 "DB\_DADOS".UA[17].USERID Identificacao do utilizador registado na UA

Network: 45 UA 18

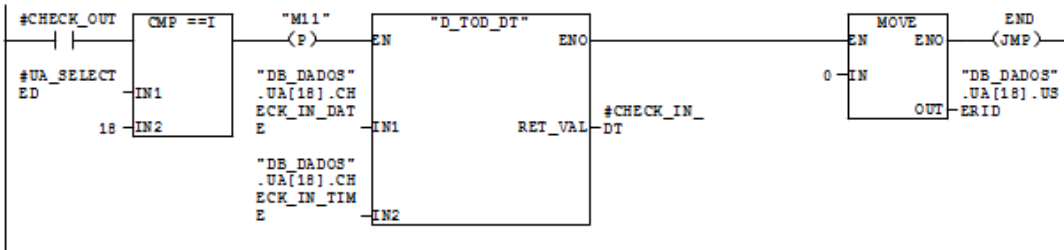

Symbol information

M2.4 M11  
 FC13 D TOD DT Date and TOD to DT  
 DB1.DBW180 "DB\_DADOS".UA[18].CHECK\_IN\_DATEdata do check-in  
 DB1.DB176 "DB\_DADOS".UA[18].CHECK\_IN\_TIMEhora do check-in  
 DB1.DBW172 "DB\_DADOS".UA[18].USERID Identificacao do utilizador registado na UA

Network: 46 UA 19

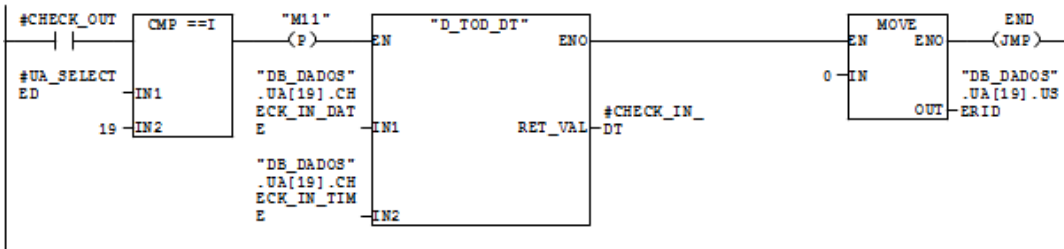

Symbol information

M2.4 M11  
 FC13 D TOD DT Date and TOD to DT  
 DB1.DBW190 "DB\_DADOS".UA[19].CHECK\_IN\_DATEdata do check-in  
 DB1.DB186 "DB\_DADOS".UA[19].CHECK\_IN\_TIMEhora do check-in  
 DB1.DBW182 "DB\_DADOS".UA[19].USERID Identificacao do utilizador registado na UA

Network: 47 UA 20

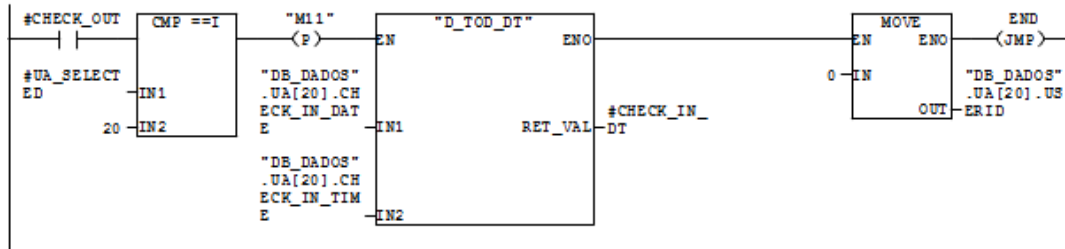

Symbol information

M2.4 M11  
 FC13 D TOD\_DT Date and TOD to DT  
 DB1.DBW200 "DB\_DADOS".UA[20].CHECK\_IN\_DATE data do check-in  
 DB1.DBD196 "DB\_DADOS".UA[20].CHECK\_IN\_TIME hora do check-in  
 DB1.DBW192 "DB\_DADOS".UA[20].USERID Identificacao do utilizador registado na UA

Network: 48 UA 21

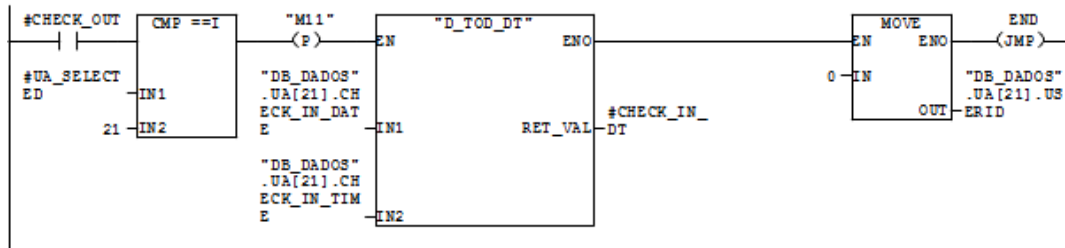

Symbol information

M2.4 M11  
 FC13 D TOD\_DT Date and TOD to DT  
 DB1.DBW210 "DB\_DADOS".UA[21].CHECK\_IN\_DATE data do check-in  
 DB1.DBD206 "DB\_DADOS".UA[21].CHECK\_IN\_TIME hora do check-in  
 DB1.DBW202 "DB\_DADOS".UA[21].USERID Identificacao do utilizador registado na UA

Network: 49 UA 22

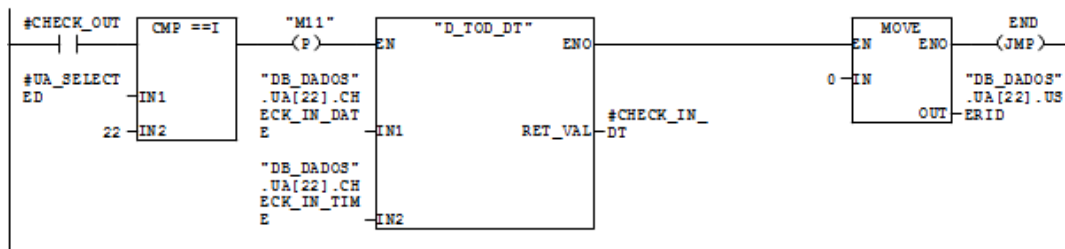

Symbol information

M2.4 M11  
 FC13 D TOD\_DT Date and TOD to DT  
 DB1.DBW220 "DB\_DADOS".UA[22].CHECK\_IN\_DATE data do check-in  
 DB1.DBD216 "DB\_DADOS".UA[22].CHECK\_IN\_TIME hora do check-in  
 DB1.DBW212 "DB\_DADOS".UA[22].USERID Identificacao do utilizador registado na UA

Network: 50 UA 23

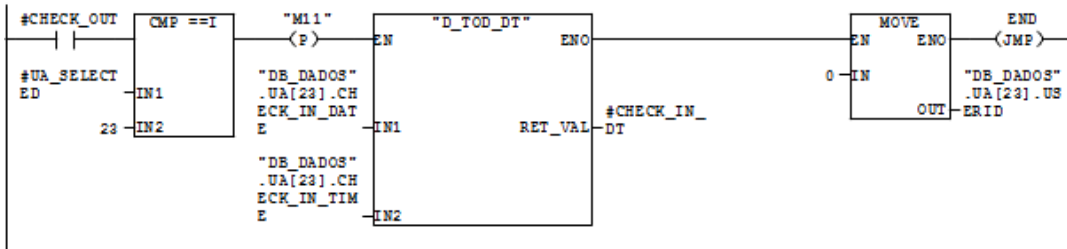

Symbol information

M2.4 M11  
 FC13 D TOD DT Date and TOD to DT  
 DB1.DBW230 "DB\_DADOS".UA[23].CHECK\_IN\_DATE data do check-in  
 DB1.DBD226 "DB\_DADOS".UA[23].CHECK\_IN\_TIME hora do check-in  
 DB1.DBW222 "DB\_DADOS".UA[23].USERID Identificacao do utilizador registado na UA

Network: 51 UA 24

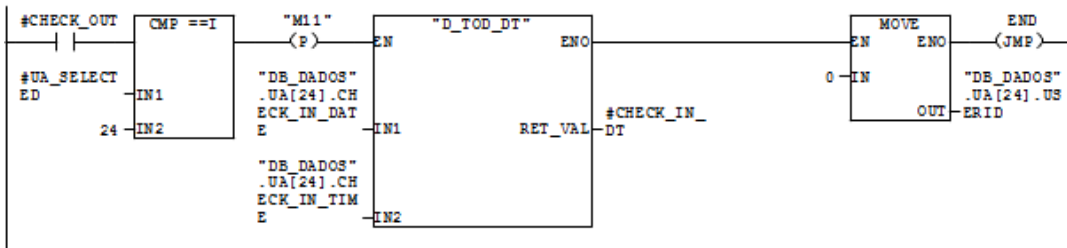

Symbol information

M2.4 M11  
 FC13 D TOD DT Date and TOD to DT  
 DB1.DBW240 "DB\_DADOS".UA[24].CHECK\_IN\_DATE data do check-in  
 DB1.DBD236 "DB\_DADOS".UA[24].CHECK\_IN\_TIME hora do check-in  
 DB1.DBW232 "DB\_DADOS".UA[24].USERID Identificacao do utilizador registado na UA

Network: 52 Termina a

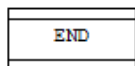

Network: 53 END Check-out

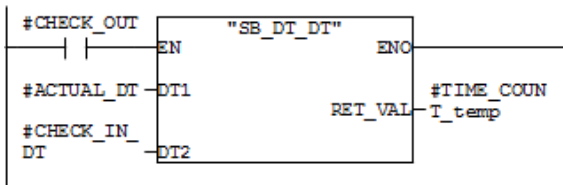

SIMATIC ...trolador\CPU 314IFM-CPU...\FC8 - <offline> 09/21/2011 16:28:45

Symbol information  
FC34 SB\_DT\_DT Subtract DT - DT

Network: 54

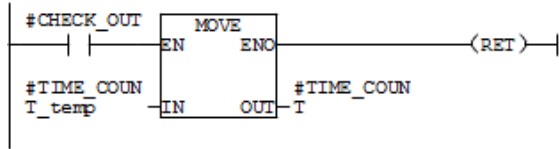



## **ANEXO II-XI**

### **FC9 “FC\_OPERATION”**

**FC9 - <offline>**

"FC OPERATION" Cordena a operacao de checkin checkout  
 Name: Family:  
 Author: Version: 0.1  
 Block version: 2  
 Time stampCode: 21-09-2011 15:18:58  
 Interface: 26-07-2011 15:37:39  
 Lengths (block/logic/data): 00592 00446 00006

Address	Declaration	Name	Type	Initial value	Comment
0.0	in	UA_SELECTED	INT		Identificacao da UA seleccionada
2.0	in	CHECKIN	BOOL		Operacao de check-in
2.1	in	CHECKOUT	BOOL		
	out				
	in out				
0.0	temp	M UM	BOOL		Memoria Temporaria
0.1	temp	M ZERO	BOOL		
0.2	temp	UA_OK	BOOL		
0.3	temp	UA_FAIL	BOOL		
0.4	temp	M ALARM	BOOL		

Block: FC9 Funcao de controlo da operacao de movimento da UA

Network: 1 Inicia o processo

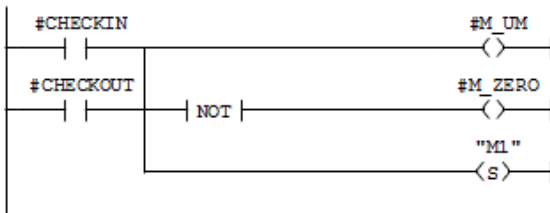

Symbol information  
 M1.0 M1

Network: 2 Movimenta a UA da posicao HOME ate a posicao de armazenamento

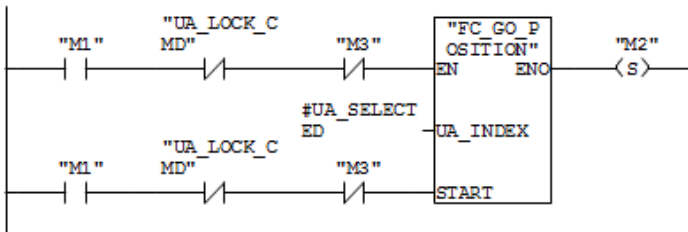

Symbol information  
 M1.0 M1  
 Q125.7 UA\_LOCK\_CMD Bloqueia a UA na plataforma do elevador  
 M1.2 M3  
 FC5 FC\_GO\_POSITION Funcao que cordena o movimento do MA para a ZER  
 M1.1 M2

Network: 3 Bloquea a UA na plataforma superior para o inicio do movimento

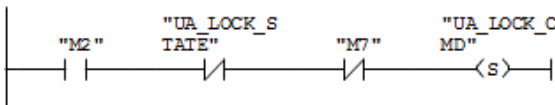

Symbol information

M1.1 M2  
 I124.7 UA\_LOCK\_STATE Estado do bloqueio da UA  
 M1.6 M7  
 Q125.7 UA\_LOCK\_CMD Bloqueia a UA na plataforma do elevador

Network: 4 Transporta a UA da sua posicao ate a recepcao

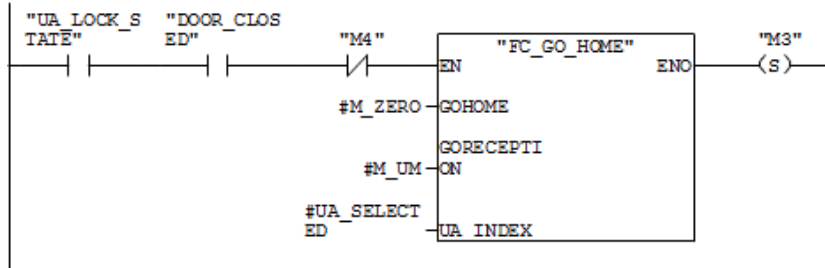

Symbol information

I124.7 UA\_LOCK\_STATE Estado do bloqueio da UA  
 I125.1 DOOR\_CLOSED Portas automaticas - Estado Fechadas  
 M1.3 M4  
 FC6 FC\_GO\_HOME Funcao que cordena o movimento do robo para a posicao HOME  
 M1.2 M3

Network: 5 Comanda a abertura e fecho das portas

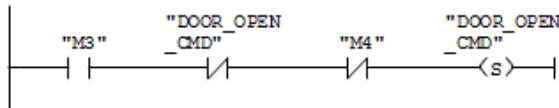

Symbol information

M1.2 M3  
 Q124.0 DOOR\_OPEN\_CMD Comando de Abertura das Portas  
 M1.3 M4

Network: 6 Inicia o processo de verificacao apos ordem de fecho das portas

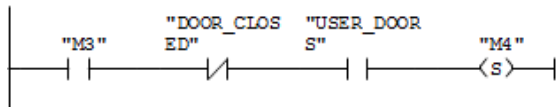

Symbol information

M1.2 M3  
 I125.1 DOOR\_CLOSED Portas automaticas - Estado Fechadas  
 I126.1 USER\_DOORS Comanda Utilizador fecho das portas  
 M1.3 M4

Network: 7 Faz a verificacao do interior da UA.

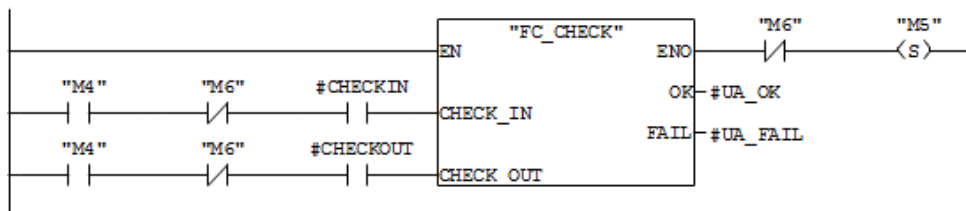

Symbol information

M1.3 M4  
 M1.5 M6  
 FC7 FC\_CHECK Verifica o conteudo da UA  
 M1.4 M5

Network: 8 Fecha as portas ou emite ALARME em caso de conteudo invalido  
 RM4 e RM5

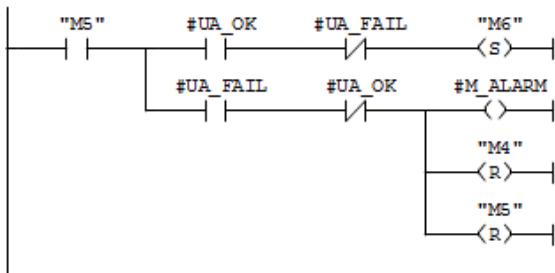

Symbol information

M1.4 M5  
 M1.5 M6  
 M1.3 M4

Network: 9

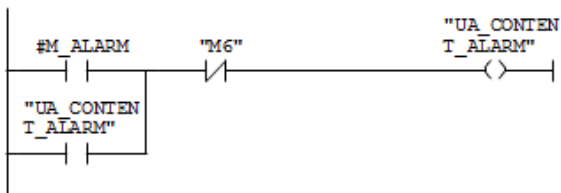

Symbol information

Q124.6 UA\_CONTENT\_ALARM Alarme de conteudo da UA invalido  
 M1.5 M6

Network: 10 Fecha a porta

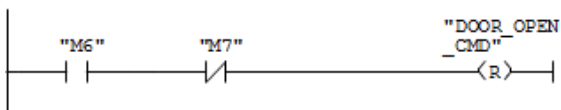

Symbol information

M1.5 M6  
 M1.6 M7  
 Q124.0 DOOR\_OPEN\_CMD Comando de Abertura das Portas

Network: 11 Volta a colocar a UA na sua posicao original

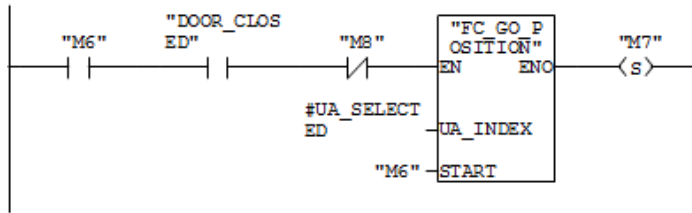

Symbol information

M1.5 M6  
 I125.1 DOOR\_CLOSED Portas automaticas - Estado Fechadas  
 M1.7 M8  
 FC5 FC\_GO\_POSITION Funcao que cordena o movimento do MA para a ZER  
 M1.6 M7

Network: 12 Desbloqueia a UA na sua posicao original

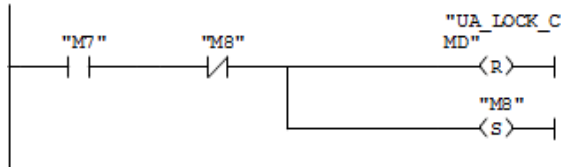

Symbol information

M1.6 M7  
 M1.7 M8  
 Q125.7 UA\_LOCK\_CMD Bloqueia a UA na plataforma do elevador

Network: 13 Transporta o robo ate a posicao home e termina

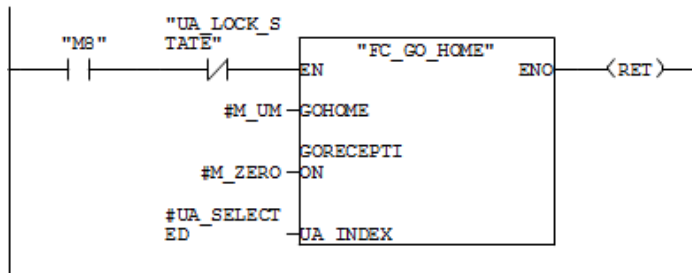

Symbol information

M1.7 M8  
 I124.7 UA\_LOCK\_STATE Estado do bloqueio da UA  
 FC6 FC\_GO\_HOME Funcao que cordena o movimento do robo para a posicao HOME



## **ANEXO II-XII**

### **DB1 “DB\_DADOS”**

SIMATIC ...trolador\CPU 314IFM-CPU...\DB1 - <offline> 09/21/2011 16:28:58

**DB1 - <offline>**

"DB\_DADOS" Guarda o registo dos utilizadores e dos ciclos de utilizacao

Name: Family:  
 Author: Version: 0.1  
 Block version: 2  
 Time stampCode: 21-09-2011 15:54:46  
 Interface: 21-09-2011 10:41:26  
 Lengths (block/logic/data): 00352 00244 00000

Block: DB1

Address	Name	Type	Initial value	Comment
0.0		STRUCT		
+0.0	DB_VAR	INT	0	Temporary placeholder variable
+2.0	UA	ARRAY[1..24]		Matriz de dados das UA
*0.0		STRUCT		
+0.0	USERID	INT	0	Identificacao do utilizador registado na UA
+2.0	CICLES COUNT	INT	0	Registo do numero de ciclos da UA
+4.0	CHECK IN TIME	TIME_OF_DAY	TOD#0:0:0.0	hora do check-in
+8.0	CHECK IN DATE	DATE	D#1990-1-1	data do check-in
=10.0		END STRUCT		
=242.0		END STRUCT		