



DVM

Technical Data Book

DVM PLUS IV Indoor Unit

SAMSUNG



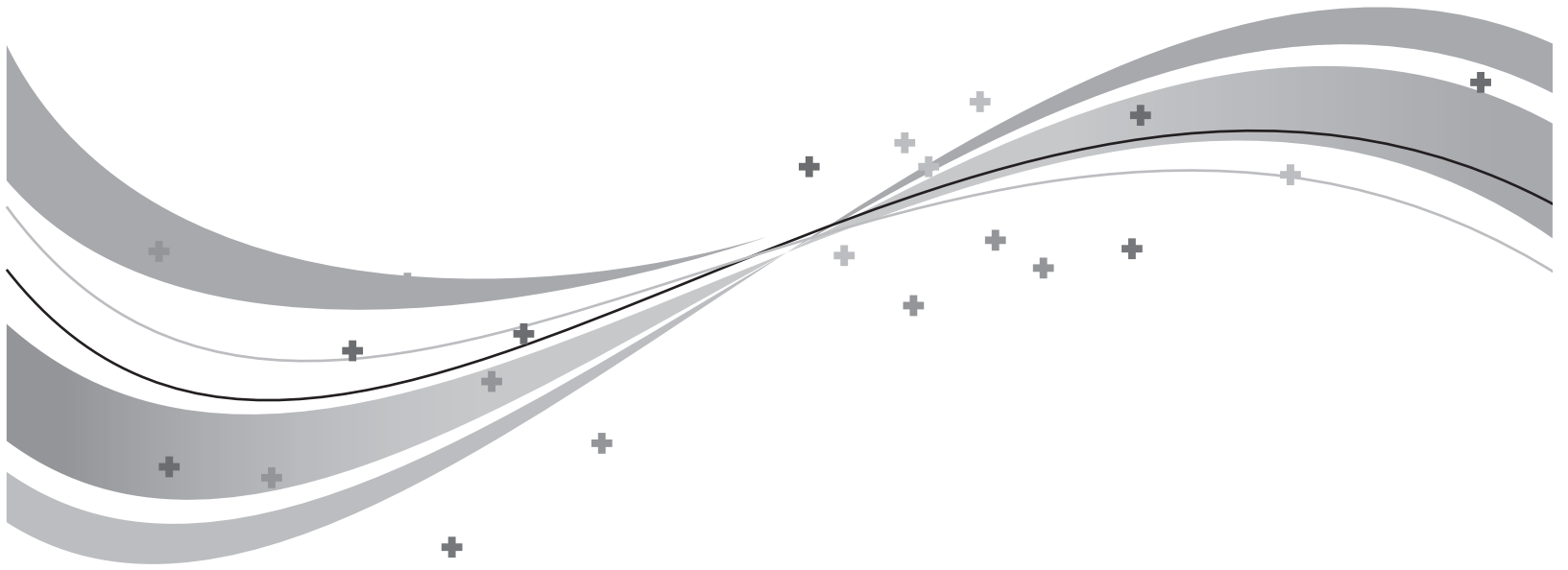

DVWM

DVM Technical Data Book

Indoor Units



Contents

I. Products

1	Nomenclature	8
2	Line-up	10
3	Accessory	11

II. Indoor units

1	Slim 1 way cassette	17
2	2 way cassette	27
3	Mini 4 way cassette	35
4	4 way cassette S	45
5	Slim duct	59
6	MSP (Middle static pressure) duct	77
7	HSP (High static pressure) duct	93
8	Console	105
9	Ceiling	117
10	Neo Forte & Neo Forte E	127
11	Vivace	143

III. Ventilation

1	ERV Plus	157
----------	----------	-----

IV. Setting

1	Setting an indoor unit address and installation option(4 way cassette S)	165
----------	--	-----



DVM PLUS IV

I. Products

1	Nomenclature.....	8
2	Line-up.....	10
3	Accessory.....	11

1 Nomenclature

1-1. Indoor units

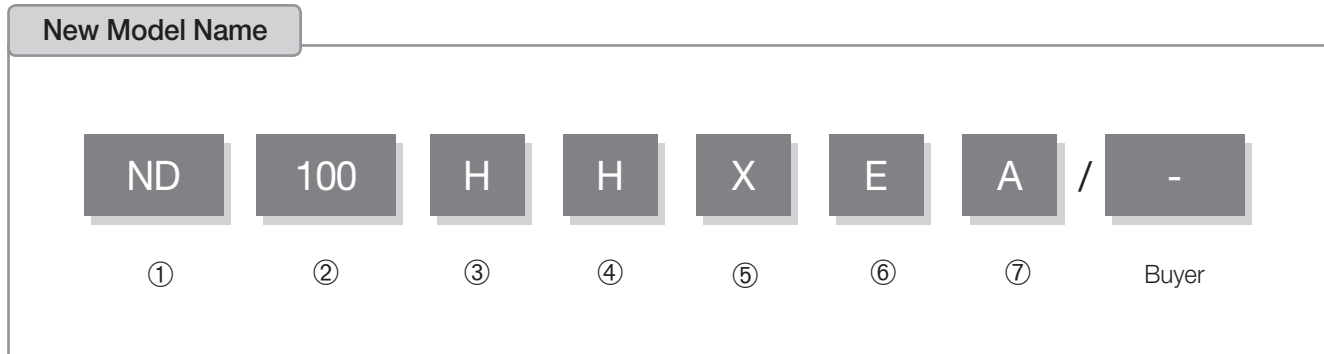

① Classification

DVM	ND
-----	----

② Capacity

X 1/10 kW (3digit)

③ Product notation

Cassette type	Slim 1 way	1
	2 way	2
	Mini 4 way	M
	4way cassette S	4
Duct type	HSP duct	H
	MSP duct	S
	LSP duct (Slim)	L
Convertible type	Ceiling	C
	Console	J
Wall mounted type	Vivace	V
	Neo-Forte E (with EEV)	Q
	Neo-Forte (without EEV)	N

④ Mode

Cooling Only	C
Heating Punmp	H

⑤ Refrigerant

R22	R
R-410A	X

⑥ Rating voltage

220V, 60Hz	B
208~230V, 60Hz	C
220~240V, 50Hz	E

⑦ Version

Export	A ~ Z
--------	-------

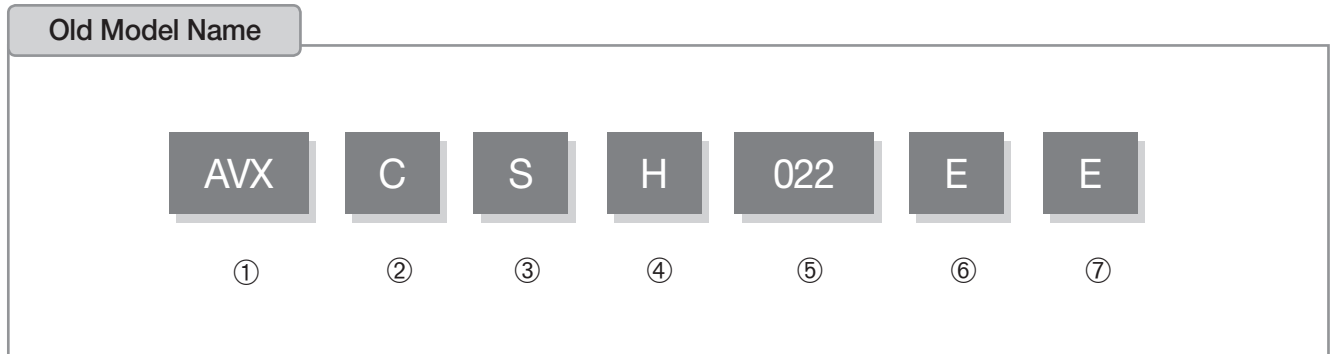

① Classification

Indoor unit (R410A)	AVX
---------------------	-----

② Classification by product group

Cassette type	C
Duct type	D
Wall mounted type	W
Convertible type	T

③ Product notation

Cassette type	Slim 1 way	S
	2 way	2
	Mini 4 way	M
	4 way	4
Duct type	Slim	S
	Middle Static Pressure	U
Wall mounted type	Neo Forte	N
	Vivace	V
Convertible type	Ceiling	F
	Console	J

④ Mode

Cooling Only	C
Heating Punmp	H
Heating Recovery	R

⑤ Capacity*

×1/10 kW (3 digits)

⑥ Rating voltage

1Ø, 220V, 60Hz	B
1Ø, 208V~230V, 60Hz	C
1Ø, 220V~240V, 50Hz	E

⑦ Version

Export	A~Z
--------	-----











2 Line-up

Capacity Type	2.2kW	2.8kW	3.6kW	4.5kW	5.6kW	6.0kW	7.1kW	9.0kW	11.2kW	12.8kW	14.0kW	22.0kW	28.0kW
Slim 1 way cassette													
2 way cassette													
4 way cassette (S)													
Mini 4 way cassette													
Slim duct													
MSP duct													
HSP duct													
Console													
Ceiling													
Neo Forte													
Neo Forte (E)													
Vivace													





Type	Air Flow Rate	250CMH	350CMH	500CMH	800CMH	1000CMH
ERV PLUS						







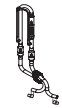

















3

Accessory

Classification	Feature	Model	Description	Relevant unit	Remark
Y-joint		MXJ-YA1509K	15.0 kW and below	DVM PLUS III DVM PLUS III HR DVM PLUS IV DVM PLUS IV HR	Requisite
		MXJ-YA2512L	Over 15.0 ~ 40.6 kW and below		
		MXJ-YA2812K	Over 40.6 ~ 46.4 kW and below		
		MXJ-YA2815K	Over 46.4 ~ 69.6 kW and below		
		MXJ-YA3119K	Over 69.6 ~ 98.6 kW and below		
		MXJ-YA3819K	Over 98.6 ~ 139.2 kW and below		
		MXJ-YA4422K	Over 139.2 kW		
Y-joint(High Pressure Gas) for DVM PLUS IV HR module		MXJ-YA1500K	23.2 kW and below	DVM PLUS III HR DVM PLUS IV HR	Requisite
		MXJ-YA2500K	Over 23.2 ~ 69.6 kW and below		
		MXJ-YA3100K	Over 69.6 ~ 139.2 kW and below		
		MXJ-YA3800K	Over 139.2 kW		
Outdoor joint (Outdoor Connection)		MXJ-T3819K	Below 48 HP	DVM PLUS III DVM PLUS III HR(Module) DVM PLUS IV DVM PLUS IV HR	Requisite
		MXJ-T4422K	Over 50 HP		
Outdoor joint (High Pressure Gas) for DVM PLUS IV HR Module		MXJ-T3100K	Below 48 HP	DVM PLUS III HR (Module) DVM PLUS IV HR	Requisite
		MXJ-T3800K	Over 50 HP		
Header joint		MXJ-HA2512K	Below 46.4 kW	DVM PLUS III DVM PLUS III HR DVM PLUS IV DVM PLUS IV HR	Requisite
		MXJ-HA3115K	Below 69.6 kW		
		MXJ-HA3819K	Over 69.7 kW		
EEV kits		MXD-A13K116A	Below 3.6 kW (1 Room) + 5.6 kW ~9.0 kW (1Room)	Wall-mounted & Ceiling indoor unit (For 2 indoor units)	Option
		MXD-A13K200A	Below 3.6 kW (2 Rooms)		
		MXD-A16K200A	5.6 kW~9.0 kW (2Rooms)		
		MXD-A22K200A	Over 9.0 kW (2Rooms)		
		MXD-A13K216A	Below 3.6 kW (2 Rooms) +5.6 kW ~ 9.0 kW (1Room)	Wall-mounted & Ceiling indoor unit (For 3 indoor units)	
		MXD-A13K300A	Below 3.6 kW (3 Rooms)		
		MXD-A16K213A	Below 3.6 kW (1 Room) + 5.6 kW ~ 9.0 kW (2Rooms)		
		MXD-A16K300A	5.6 kW ~ 9.0 kW (3Rooms)		
		MEV-A13SA	Below 3.6 kW (1 Room)	Wall-mounted & Ceiling indoor unit (For single unit)	
		MEV-A16SA	5.6 kW ~ 9.0 kW (1Room)		
Drain pump		MDP-N047SNC1	HSP Duct 22.0/28.0kW	-	Option
		MDP-M075SGU1	MSP Duct (9.0/11.2) kW	-	Option
		MDP-M075SGU2	MSP Duct (12.8/14.0) kW		
		MDP-M075SGU3	MSP Duct (5.6/7.1) kW		
		MDP-E075SEE3	SlimDuct (2.0~14.0)kW	-	Option

3 Accessory

Classification	Feature	Model	Description	Relevant unit	Remark
MCU kits		MCU-Y4NEE	Below 4 indoors	DVM PLUS III HR DVM PLUS IV HR	Requisite (HR only)
		MCU-Y6NEE	Below 6 indoors		
		MCU-Y4NEE1	Below 4 indoors (HSP 22.0/28.0kW)		
AHU kit		MXD-A16K1X025A	7.0kW~8.75kW	-	Option
		MXD-A22K1X050A	14.0kW~17.5kW		
		MXD-A22K2X075A	21.0kW~26.25kW		
		MXD-A22K2X100A	28.0kW~35.0kW		
Front panel		PSSMA	Slim 1 way cassette	-	Requisite
		P2SMA	2 way cassette		
		PMSMA	Mini 4 way cassette		
		P4SMA	4 way cassette		
		PC4NUSKA	4 way cassette - Waffle		
		PC4NUSKE	4 way cassette - Classic		
		PC4NBSKA	4 way cassette - Classic, Black		
PDM kit		MXD-A38K2A	8~12HP	DVM PLUS IV	Option
		MXD-A12K2A	14~16HP		
		MXD-A58K2A	18~20HP		
Humidifier		MVO-VA050100	RHF050KHEA	-	
		MVO-VA100100	RHF100KHEA		
SPI kit		MSD-CAN1	4way cassette	-	Option
		MSD-EAN1	ERV PLUS	-	

Classification		Product	Model	Image	Application model	
Integrated management system	Controller	DMS 2	MIM-D00A		DVM Series, FJM, CAC, ERV, ERV Plus	
		S-NET 3	MST-P3P		DVM Series, FJM, CAC, ERV, ERV Plus	
		S-NET mini	MST-S3W		DVM Series, FJM, CAC, ERV, ERV Plus	
Centralized control system	Controller	Centralized controller	MCM-A202D		DVM Series, FJM, CAC, ERV, ERV Plus	
		Function controller	MCM-A100		DVM Series, FJM, CAC	
		Operation mode selection switch	MCM-C200		DVM Series(Except HR models)	
	Interface module	Centralized controller interface module	MIM-B13E		DVM Series, FJM, CAC, ERV	
			MIM-B13D		DVM Series, FJM, CAC, ERV, ERV Plus	
Individual control system Controller	Controller	Wireless remote controller	MR-DH00		Cassette, Duct(Receiver needed)	
		Wired remote controller (Multi function)	MWR-WE10		Cassette, Wall-mounted, Ceiling, Duct, Console, ERV, ERV Plus	
		Wired remote controller	MWR-WH00		Cassette, Wall-mounted, Ceiling, Duct, Console	
		Simplified wired remote controller	MWR-SH00		Cassette, Wall-mounted, Ceiling, Duct, Console	
		ERV CO ₂ series	MOS-C1		ERV, ERV Plus	
		ERV Wired remote controller	MWR-VH02		ERV	
		Wireless signal receiver kit	Wireless signal receiver	MRK-A00		Duct (For wireless remote controller)
			Receiver wire	MRW-10A		Duct (For wireless remote controller)
		7-day scheduler	MWR-BS00		Cassette, Wall-mounted, Duct	
		Remote sensor	MRW-TA		Cassette, Wall-mounted, Ceiling, Duct, Console	
Building management system	Lonworks interface module	MIM-B07		DVM Series, FJM		
		MIM-B18		DVM Series, FJM, CAC, ERV		
	DMS-Bnet (BACnet)	MIM-B17		DVM Series, FJM		
Guest room management system	Key-tag interface module	MIM-B02		DVM Series, FJM		
	External contact interface module	MIM-B14		Mini DVM(R-410A), DVM PLUS III, FJM, ERV Plus		
Power distribution			MIM-B16		DVM Series, FJM	

* DVM Series : DVM mini, DVM PLUS III, DVM PLUS III HR, DVM PLUS IV, DVM PLUS IV HR



DVM PLUS IV

II. Indoor units

1	Slim 1 way cassette	17
2	2 way cassette	27
3	Mini 4 way cassette.....	35
4	4 way cassette S.....	45
5	Slim duct.....	59
6	MSP (Middle static pressure) duct.....	77
7	HSP (High static pressure) duct	93
8	Console.....	105
9	Ceiling	117
10	Neo Forte & Neo Forte E.....	127
11	Vivace	143



INDOOR UNIT



1 Slim 1 way cassette

(AVXCSH***E*)

- 1-1. Specifications..... 18
- 1-2. Capacity tables 19
- 1-3. Dimensional drawing 21
- 1-4. PCB connector lay-out..... 22
- 1-5. Electrical wiring diagram 23
- 1-6. Sound pressure level 24
- 1-7. Temperature and air flow distribution..... 25

Optional Accessories

Individual Controllers



MWR-WE10



MWR-WH00



MWR-SH00



MR-DH00

Panel



PSSMA

1 Slim 1 way cassette

1-1. Specifications

1) Technical specifications

Model			AVXCSH022E*	AVXCSH028E*	AVXCSH036E*	
Power Supply			Ø, #, V, Hz	1, 2, 220~240, 50	1, 2, 220~240, 50	
Mode*1)			-	HP / HR	HP / HR	
Capacity (Nominal)	Cooling*2)	kW	2.2	2.8	3.6	
		Btu/h	7,500	9,600	12,300	
	Heating*3)	kW	2.5	3.2	4.0	
		Btu/h	8,500	10,900	13,600	
Power	Power Input (Nominal)	Cooling*2)	W	40	45	
		Heating*3)	W	40	45	
	Current Input (Nominal)	Cooling*2)	A	0.20	0.23	
		Heating*3)	A	0.20	0.23	
Fan	Motor	Type	-	Crossflow Fan / SSR	Crossflow Fan / SSR	
		Output	W	23	23	
		Number of unit	EA	1	1	
	Air Flow Rate	H/M/L (UL)	CMM	6 / 5 / 4	7 / 6 / 5	8 / 7 / 6
			CFM	210 / 180 / 140	250 / 210 / 180	280 / 250 / 210
	External Pressure	Min / Std / Max	mmAq	-	-	-
			Pa	-	-	-
WG			-	-	-	
Option Code			-	078605-1120C8-200000-300000	078605-1320F8-200000-300000	
Piping Connections	Liquid Pipe	Ø, mm	6.35	6.35	6.35	
		Ø, inch	1/4	1/4	1/4	
	Gas Pipe	Ø, mm	12.7	12.7	12.7	
		Ø, inch	1/2	1/2	1/2	
	Drain Pipe	Ø, mm	ID20 Hose (OD 25, ID 20)	ID20 Hose (OD 25, ID 20)	ID20 Hose (OD 25, ID 20)	
Field Wiring	Power Source Wire	Below 20m / over 20m	mm ²	1.5 / 2.5	1.5 / 2.5	
	Transmission Cable		mm ²	0.75 / 1.5	0.75 / 1.5	
Refrigerant	Type	-	R410A	R410A	R410A	
	Control Method	-	EEV	EEV	EEV	
Sound	Sound Pressure	High / Low*4)	dBA	30 / 25	32 / 27	
Dimensions	Net Weight		kg	11	11	
	Shipping Weight		kg	14	14	
	Net Dimensions (WxHxD)		mm	970 x 135 x 410	970 x 135 x 410	
	Shipping Dimensions (WxHxD)		mm	1,164 x 212 x 478	1,164 x 212 x 478	
Panel Size	Panel model		-	PSSMA	PSSMA	
	Panel Net Weight		kg	3.0	3.0	
	Shipping Weight		kg	5.0	5.0	
	Net Dimensions (WxHxD)		mm	1,180 x 25 x 460	1,180 x 25 x 460	
	Shipping Dimensions (WxHxD)		mm	1,259 x 144 x 539	1,259 x 144 x 539	
Additional Accessories	Drain pump	Drain pump	- / Model	Built-in	Built-in	
		Max. lifting Height / Displacement	mm/liter/h	750 / 24	750 / 24	
	Air Filter		-	Long life filter	Long life filter	

* Specifications may be subject to change without prior notice for product improvement.

*1) Mode

- HP : Heat Pump, HR : Heat Recovery

*2) Nominal cooling capacities are based on;

- Indoor temperature : 27°C DB, 19°C WB

- Outdoor temperature : 35°C DB, 24°C WB, Equivalent refrigerant piping : 7.5m, Level differences : 0m

*3) Nominal heating capacities are based on;

- Indoor temperature : 20°C DB, 15°C WB

- Outdoor temperature : 7°C DB, 6°C WB, Equivalent refrigerant piping : 7.5m, Level differences : 0m

*4) Sound pressure was acquired in a dead room. Thus actual noise level may be different depending on the installation conditions.

1-2. Capacity tables

1) Cooling

TC : Total Capacity(kW), SHC : Sensible Heat Capacity(kW)

Model	Outdoor temperature (°C, DB)	Indoor temperature (°C, WB)													
		20 (°C, DB) 14 (°C, WB)		23 (°C, DB) 16 (°C, WB)		26 (°C, DB) 18 (°C, WB)		27 (°C, DB) 19 (°C, WB)		28 (°C, DB) 20 (°C, WB)		30 (°C, DB) 22 (°C, WB)		32 (°C, DB) 24 (°C, WB)	
		TC	SHC	TC	SHC	TC	SHC	TC	SHC	TC	SHC	TC	SHC	TC	SHC
022	10	1.5	1.3	1.8	1.4	2.1	1.5	2.2	1.5	2.3	1.5	2.5	1.6	2.6	1.4
	12	1.5	1.3	1.8	1.4	2.1	1.5	2.2	1.5	2.3	1.5	2.5	1.6	2.6	1.4
	14	1.5	1.3	1.8	1.4	2.1	1.5	2.2	1.5	2.3	1.5	2.5	1.6	2.6	1.4
	16	1.5	1.3	1.8	1.4	2.1	1.5	2.2	1.5	2.3	1.5	2.4	1.5	2.6	1.4
	18	1.5	1.3	1.8	1.4	2.1	1.5	2.2	1.5	2.3	1.5	2.4	1.5	2.6	1.4
	20	1.5	1.3	1.8	1.4	2.1	1.5	2.2	1.5	2.3	1.5	2.4	1.5	2.6	1.4
	21	1.5	1.3	1.8	1.4	2.1	1.5	2.2	1.5	2.3	1.5	2.4	1.5	2.6	1.4
	23	1.5	1.3	1.8	1.4	2.1	1.5	2.2	1.5	2.3	1.5	2.4	1.5	2.6	1.4
	25	1.5	1.3	1.8	1.4	2.1	1.5	2.2	1.5	2.3	1.5	2.4	1.5	2.6	1.4
	27	1.5	1.3	1.8	1.4	2.1	1.5	2.2	1.5	2.3	1.5	2.4	1.5	2.6	1.4
	29	1.5	1.3	1.8	1.4	2.1	1.5	2.2	1.5	2.3	1.5	2.4	1.5	2.6	1.4
	31	1.5	1.3	1.8	1.4	2.1	1.5	2.2	1.5	2.3	1.5	2.4	1.5	2.6	1.4
	33	1.5	1.3	1.8	1.4	2.1	1.5	2.2	1.5	2.3	1.5	2.4	1.5	2.6	1.4
	35	1.5	1.3	1.8	1.4	2.1	1.5	2.2	1.5	2.3	1.5	2.4	1.5	2.6	1.4
	37	1.5	1.3	1.8	1.4	2.1	1.5	2.2	1.5	2.3	1.5	2.4	1.5	2.6	1.4
39	1.5	1.3	1.8	1.4	2.1	1.5	2.2	1.5	2.3	1.5	2.4	1.5	2.5	1.3	
42	1.5	1.3	1.8	1.4	2.1	1.5	2.1	1.4	2.2	1.4	2.3	1.4	2.4	1.2	
44	1.5	1.3	1.8	1.4	2.0	1.4	2.1	1.4	2.1	1.3	2.2	1.4	2.2	1.1	
028	10	1.9	1.6	2.3	1.8	2.6	1.9	2.8	1.9	2.9	1.9	3.1	1.9	3.4	1.9
	12	1.9	1.6	2.3	1.8	2.6	1.9	2.8	1.9	2.9	1.9	3.1	1.9	3.3	1.8
	14	1.9	1.6	2.3	1.8	2.6	1.9	2.8	1.9	2.9	1.9	3.1	1.9	3.3	1.8
	16	1.9	1.6	2.3	1.8	2.6	1.9	2.8	1.9	2.9	1.9	3.1	1.9	3.3	1.8
	18	1.9	1.6	2.3	1.8	2.6	1.9	2.8	1.9	2.9	1.9	3.1	1.9	3.3	1.8
	20	1.9	1.6	2.3	1.8	2.6	1.9	2.8	1.9	2.9	1.9	3.1	1.9	3.3	1.8
	21	1.9	1.6	2.3	1.8	2.6	1.9	2.8	1.9	2.9	1.9	3.1	1.9	3.3	1.8
	23	1.9	1.6	2.3	1.8	2.6	1.9	2.8	1.9	2.9	1.9	3.1	1.9	3.3	1.8
	25	1.9	1.6	2.3	1.8	2.6	1.9	2.8	1.9	2.9	1.9	3.1	1.9	3.3	1.8
	27	1.9	1.6	2.3	1.8	2.6	1.9	2.8	1.9	2.9	1.9	3.1	1.9	3.3	1.8
	29	1.9	1.6	2.3	1.8	2.6	1.9	2.8	1.9	2.9	1.9	3.1	1.9	3.3	1.8
	31	1.9	1.6	2.3	1.8	2.6	1.9	2.8	1.9	2.9	1.9	3.1	1.9	3.3	1.8
	33	1.9	1.6	2.3	1.8	2.6	1.9	2.8	1.9	2.9	1.9	3.1	1.9	3.3	1.8
	35	1.9	1.6	2.3	1.8	2.6	1.9	2.8	1.9	2.9	1.9	3.1	1.9	3.3	1.8
	37	1.9	1.6	2.3	1.8	2.6	1.9	2.8	1.9	2.9	1.9	3.1	1.9	3.3	1.8
39	1.9	1.6	2.3	1.8	2.6	1.9	2.8	1.9	2.9	1.9	3.0	1.8	3.2	1.7	
42	1.9	1.6	2.3	1.8	2.6	1.9	2.7	1.8	2.8	1.8	2.9	1.7	3.0	1.6	
44	1.9	1.6	2.3	1.8	2.5	1.8	2.7	1.8	2.7	1.7	2.7	1.6	2.8	1.5	
036	10	2.5	2.2	2.9	2.4	3.4	2.4	3.6	2.6	3.7	2.6	4.0	2.6	4.3	2.5
	12	2.5	2.2	2.9	2.4	3.4	2.4	3.6	2.6	3.7	2.6	4.0	2.6	4.3	2.5
	14	2.5	2.2	2.9	2.4	3.4	2.4	3.6	2.6	3.7	2.6	4.0	2.6	4.3	2.5
	16	2.5	2.2	2.9	2.4	3.4	2.4	3.6	2.6	3.7	2.6	4.0	2.6	4.3	2.5
	18	2.5	2.2	2.9	2.4	3.4	2.4	3.6	2.6	3.7	2.6	4.0	2.6	4.3	2.5
	20	2.5	2.2	2.9	2.4	3.4	2.4	3.6	2.6	3.7	2.6	4.0	2.6	4.2	2.4
	21	2.5	2.2	2.9	2.4	3.4	2.4	3.6	2.6	3.7	2.6	4.0	2.6	4.2	2.4
	23	2.5	2.2	2.9	2.4	3.4	2.4	3.6	2.6	3.7	2.6	4.0	2.6	4.2	2.4
	25	2.5	2.2	2.9	2.4	3.4	2.4	3.6	2.6	3.7	2.6	4.0	2.6	4.2	2.4
	27	2.5	2.2	2.9	2.4	3.4	2.4	3.6	2.6	3.7	2.6	4.0	2.6	4.2	2.4
	29	2.5	2.2	2.9	2.4	3.4	2.4	3.6	2.6	3.7	2.6	4.0	2.6	4.2	2.4
	31	2.5	2.2	2.9	2.4	3.4	2.4	3.6	2.6	3.7	2.6	4.0	2.6	4.2	2.4
	33	2.5	2.2	2.9	2.4	3.4	2.4	3.6	2.6	3.7	2.6	4.0	2.6	4.2	2.4
	35	2.5	2.2	2.9	2.4	3.4	2.4	3.6	2.6	3.7	2.6	4.0	2.6	4.2	2.4
	37	2.5	2.2	2.9	2.4	3.4	2.4	3.6	2.6	3.7	2.6	3.9	2.5	4.2	2.4
39	2.5	2.2	2.9	2.4	3.4	2.4	3.6	2.6	3.7	2.6	3.9	2.5	4.1	2.3	
42	2.5	2.2	2.9	2.4	3.4	2.4	3.5	2.5	3.6	2.5	3.7	2.4	3.9	2.1	
44	2.5	2.2	2.9	2.4	3.2	2.3	3.4	2.4	3.5	2.4	3.5	2.3	3.6	2.0	

Indoor units

1 Slim 1 way cassette

1-2. Capacity tables

2) Heating

TC : Total Capacity(kW)

Model	Outdoor temperature (°C)		Indoor temperature (°C, DB)				
			16.0	18.0	20.0	22.0	24.0
	DB	WB	TC kW	TC kW	TC kW	TC kW	TC kW
022	-20	-21	1.5	1.5	1.5	1.5	1.5
	-17	-18	1.6	1.6	1.6	1.6	1.6
	-15	-16	1.7	1.6	1.6	1.6	1.6
	-12	-13	1.8	1.8	1.8	1.8	1.7
	-10	-11	2.0	2.0	1.9	1.9	1.9
	-7	-8	2.3	2.2	2.2	2.0	2.0
	-5	-6	2.4	2.3	2.3	2.2	2.2
	-3	-4	2.5	2.5	2.4	2.3	2.2
	0	-1	2.6	2.5	2.5	2.3	2.2
	3	2.2	2.7	2.6	2.5	2.3	2.2
	5	4.1	2.8	2.7	2.5	2.3	2.2
	7	6	2.8	2.7	2.5	2.3	2.2
	9	7.9	3.0	2.7	2.5	2.3	2.2
	11	9.8	3.0	2.7	2.5	2.3	2.2
	13	12	3.0	2.7	2.5	2.3	2.2
15	14	3.0	2.7	2.5	2.3	2.2	
028	-20	-21	1.9	1.9	1.9	1.9	1.9
	-17	-18	2.0	2.0	2.0	2.0	1.9
	-15	-16	2.1	2.1	2.0	2.0	1.9
	-12	-13	2.2	2.2	2.2	2.1	2.1
	-10	-11	2.3	2.3	2.3	2.3	2.2
	-7	-8	2.5	2.4	2.4	2.4	2.3
	-5	-6	2.6	2.6	2.5	2.5	2.4
	-3	-4	2.8	2.7	2.7	2.6	2.5
	0	-1	2.9	2.8	2.8	2.7	2.6
	3	2.2	3.0	3.0	2.9	2.8	2.7
	5	4.1	3.2	3.1	3.1	2.9	2.7
	7	6	3.3	3.2	3.2	3.0	2.7
	9	7.9	3.4	3.3	3.2	3.0	2.7
	11	9.8	3.5	3.3	3.2	3.0	2.7
	13	12	3.6	3.4	3.2	3.0	2.7
15	14	3.7	3.4	3.2	3.0	2.7	
036	-20	-21	2.4	2.4	2.3	2.3	2.3
	-17	-18	2.6	2.5	2.4	2.4	2.3
	-15	-16	2.7	2.6	2.5	2.5	2.4
	-12	-13	2.8	2.7	2.7	2.6	2.6
	-10	-11	2.9	2.9	2.9	2.8	2.8
	-7	-8	3.1	3.1	3.0	3.0	2.9
	-5	-6	3.3	3.2	3.2	3.1	3.0
	-3	-4	3.4	3.4	3.3	3.2	3.1
	0	-1	3.6	3.6	3.5	3.4	3.2
	3	2.2	3.8	3.7	3.7	3.5	3.4
	5	4.1	3.9	3.9	3.8	3.6	3.4
	7	6	4.1	4.1	4.0	3.7	3.4
	9	7.9	4.2	4.1	4.0	3.7	3.4
	11	9.8	4.4	4.2	4.0	3.7	3.4
	13	12	4.5	4.2	4.0	3.7	3.4
15	14	4.6	4.3	4.0	3.7	3.4	

1-3. Dimensional drawing

Unit:mm

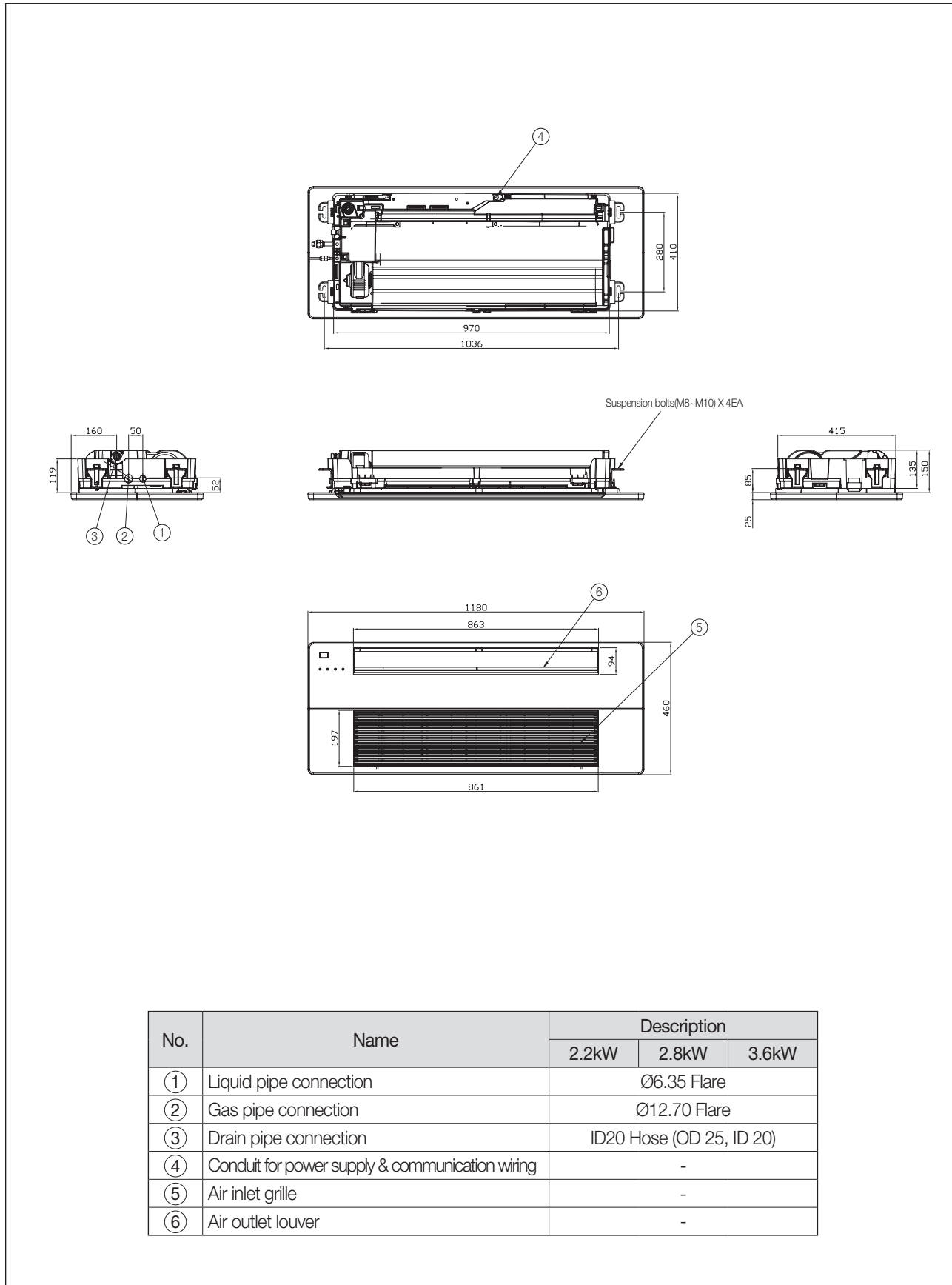

Indoor units



No.	Name	Description		
		2.2kW	2.8kW	3.6kW
①	Liquid pipe connection	Ø6.35 Flare		
②	Gas pipe connection	Ø12.70 Flare		
③	Drain pipe connection	ID20 Hose (OD 25, ID 20)		
④	Conduit for power supply & communication wiring	-		
⑤	Air inlet grille	-		
⑥	Air outlet louver	-		

1 Slim 1 way cassette

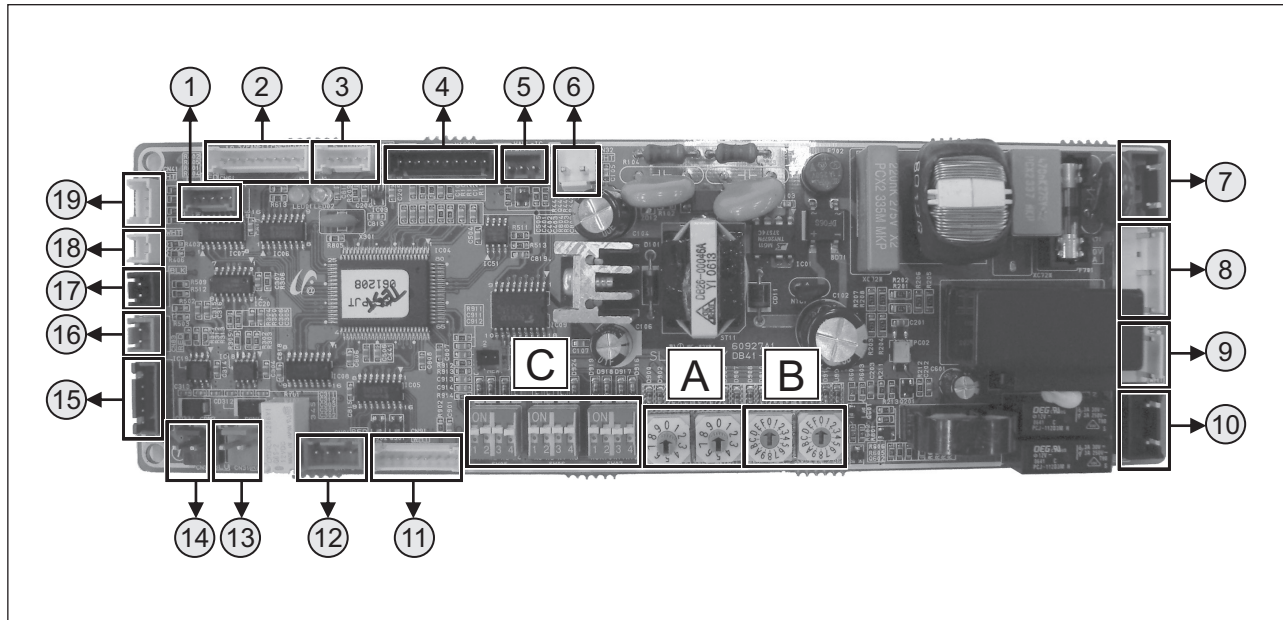
1-4. PCB connector lay-out

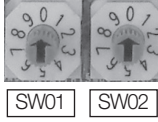

No.	CN #	COLOR	FUNCTION
①	CN61	Red	Sliding Panel 1(Only for sliding panel)
②	CN62	White	Sliding Panel 2 (Only for sliding panel)
③	CN60	White	Louver
④	CN10	Black	MICOM Download
⑤	CN44	Blue	Hall IC
⑥	CN32	White	DC 12V for Wired Remote Controller
⑦	CN71	Blue	AC 230V Input
⑧	CN73	White	Fan Motor
⑨	CN74	White	Drain Pump
⑩	CN75	Black	Ventilator
⑪	CN91	White	Display
⑫	CN81	Red	Error Check, Indoor unit Operation
⑬	CN31	Red	Communication with Outdoor Units (COM1)
⑭	CN33	Blue	Communication with Wired Remote Controller (COM2)
⑮	CN63	Blue	EEV
⑯	CN83	Red	External Contact Control
⑰	CN51	Black	Float Switch
⑱	CN42	White	Eva-Out Sensor
⑲	CN41	White	Room Sensor, Eva-In Sensor

No.	S/W	FUNCTION	
A	 SW01 SW02	Main Address Setting (00~63)	
		SW03	SW04
B	 SW03 SW04	Address of Interface Module Channel 0~2	Group Address (RMC) for Centralized Control 0~F

No.	S/W	FUNCTION	ON	OFF
C	K1	-	-	-
	K2	Centralized Controller	Not use	Use
	K3	RPM Up	N/A	N/A
	K4	Optional Drain Pump	N/A	N/A
	K5	Heating Thermo-off	+2°C	+5°C
	K6	Filter Signal Display	1,000hrs	2,000hrs
	K7	Hot Water Coil	N/A	N/A
	K8	Electrical Heater	N/A	N/A
	K9	Min. EEV Step at Heating	Fixed 80 step	0 or 80 step
	K10	Priority of Indoor unit Display on Wired Remote Control	Slave (Default)	Master
	K11	External Contact Control	Not use	Use
	K12	-	-	-

1-5. Electrical wiring diagram

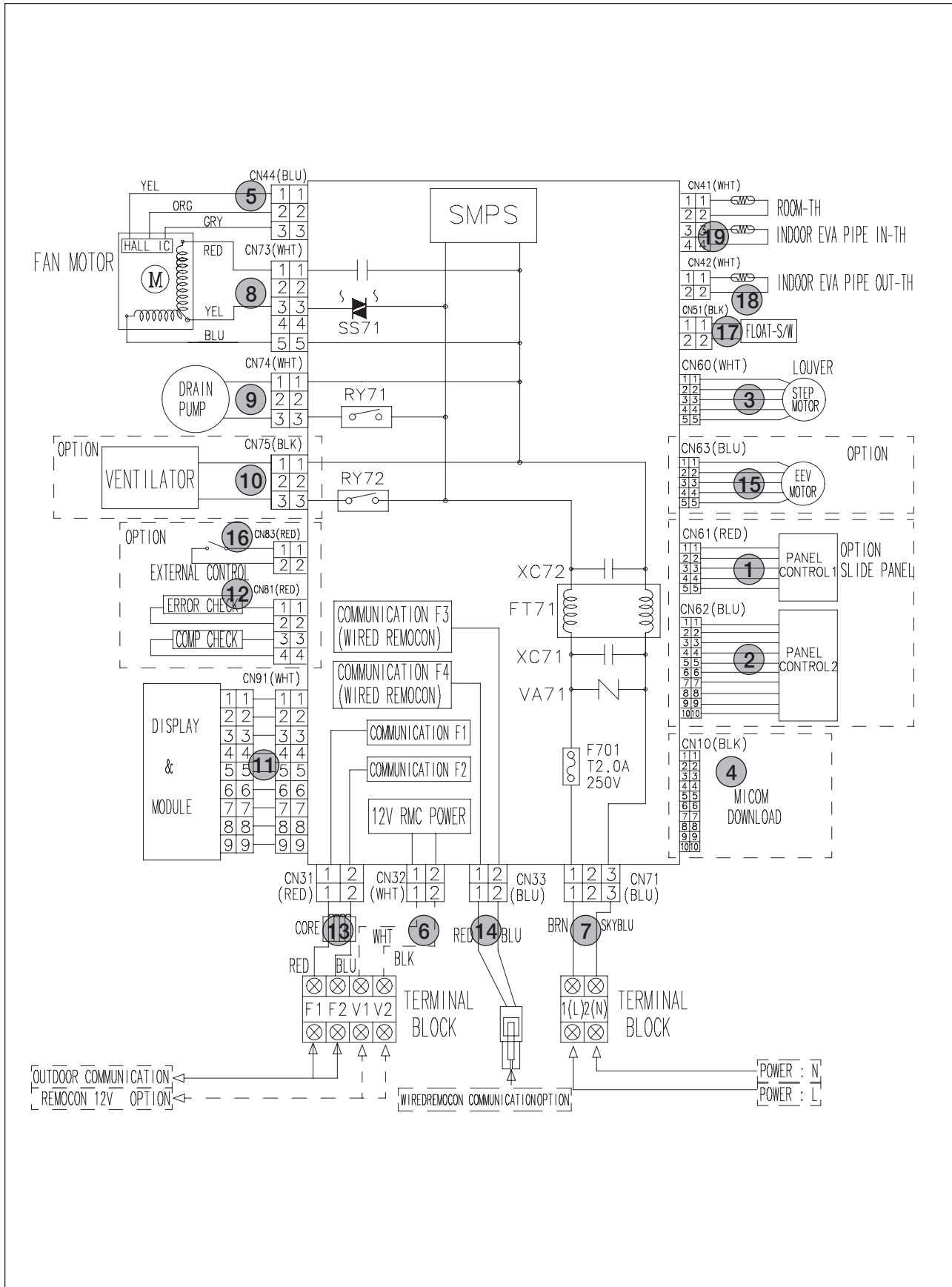

Indoor units

1 Slim 1 way cassette

1-6. Sound pressure level

1) Operation sound level

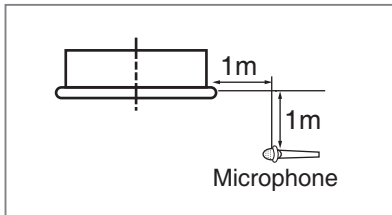

Unit : dB(A)

Model	High	Low
AVXCSH022E*	30	25
AVXCSH028E*	30	25
AVXCSH036E*	32	27

☑ Note

- ◆ These operation values were obtained in a dead room. Sound pressure level will vary depending on a range of factors such as the construction of the particular room where the equipment is installed.
- ◆ Operation sound level may differ depending on operation and ambient conditions.

2) NC curves

(1) AVXCSH022E*

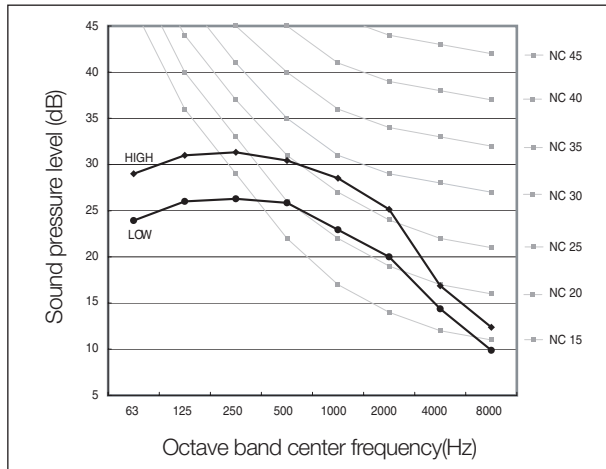

(2) AVXCSH028E*

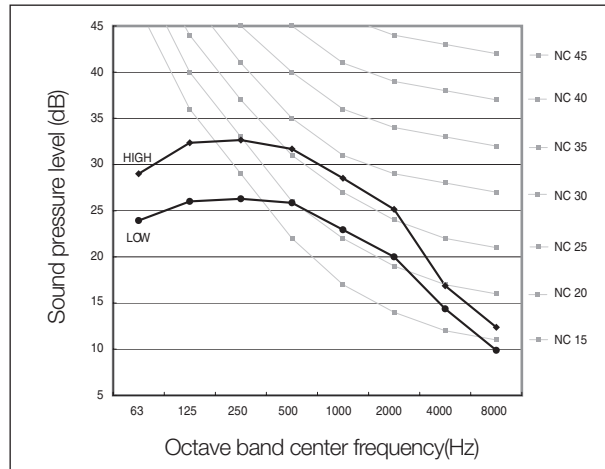

(3) AVXCSH036E*

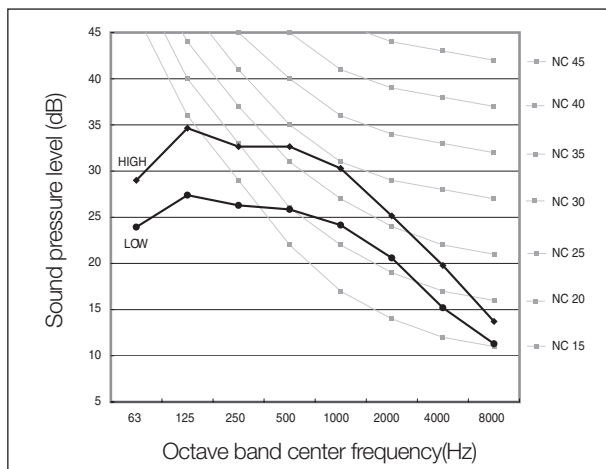

1-7. Temperature and air flow distribution

1) AVXCSH036E*

(1) Cooling air velocity distribution

◆ Discharge angle : 60°

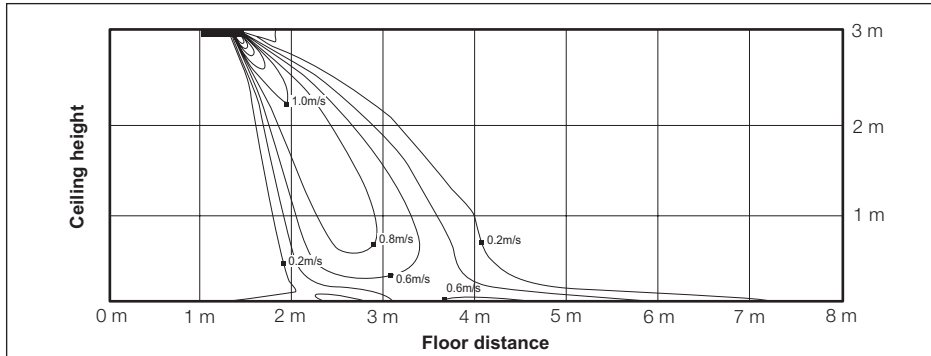

(2) Cooling temperature distribution

◆ Discharge angle : 60°

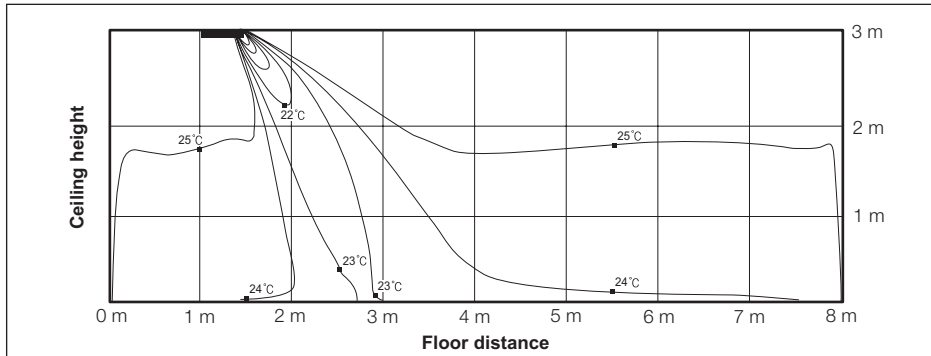

(3) Heating air velocity distribution

◆ Discharge angle : 60°

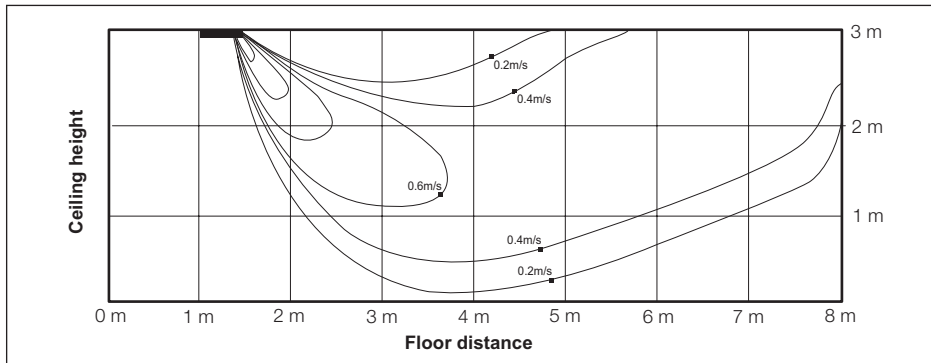

(4) Heating temperature distribution

◆ Discharge angle : 60°

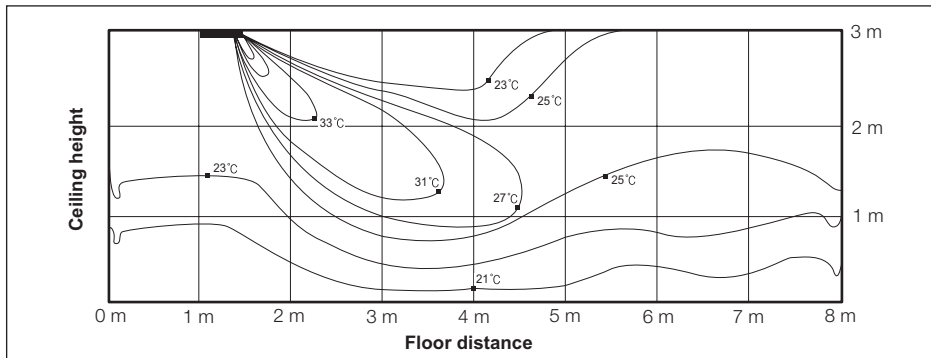



INDOOR UNIT



2 2 way cassette (AVXC2H***E*)

- 2-1. Specifications..... 28
- 2-2. Capacity tables 29
- 2-3. Dimensional drawing..... 30
- 2-4. PCB connector lay-out..... 31
- 2-5. Electrical wiring diagram 32
- 2-6. Sound pressure level 33
- 2-7. Temperature and air flow distribution..... 34

Optional Accessories

Individual Controllers



MWR-WE10



MWR-WH00



MWR-SH00



MR-DH00

Panel



P2SMA

2-1. Specifications

1) Technical specifications

Model				AVXC2H056E*	AVXC2H071E*	
Power Supply			Ø, #, V, Hz	1, 2, 220~240, 50	1, 2, 220~240, 50	
Mode*1)			-	HP / HR	HP / HR	
Capacity (Nominal)	Cooling*2)		kW	5.6	7.1	
			Btu/h	19,100	24,200	
	Heating*3)		kW	6.3	8.0	
			Btu/h	21,500	27,300	
Power	Power Input (Nominal)	Cooling*2)	W	70	75	
		Heating*3)		70	75	
	Current Input (Nominal)	Cooling*2)	A	0.38	0.40	
		Heating*3)		0.38	0.40	
Fan	Motor	Type	-	Crossflow Fan / SSR	Crossflow Fan / SSR	
		Output	W	14	14	
		Number of unit	EA	2	2	
	Air Flow Rate	H/M/L (UL)	CMM		14 / 13 / 12	15 / 14 / 13
			CFM		490 / 460 / 420	530 / 490 / 460
	External Pressure	Min / Std / Max	mmAq		-	-
			Pa		-	-
			WG		-	-
Option Code			-	025600-194361-200000-300000	025600-1d4382-200000-300000	
Piping Connections	Liquid Pipe	Ø, mm		6.35	9.52	
		Ø, inch		1/4	3/8	
	Gas Pipe	Ø, mm		12.7	15.88	
		Ø, inch		1/2	5/8	
	Drain Pipe	Ø, mm		ID25 Hose (OD 32, ID 25)	ID25 Hose (OD 32, ID 26)	
Field Wiring	Power Source Wire	Below 20m / over 20m	mm ²	1.5 / 2.5	1.5 / 2.5	
	Transmission Cable		mm ²	0.75 / 1.5	0.75 / 1.5	
Refrigerant	Type		-	R410A	R410A	
	Control Method		-	EEV	EEV	
Sound	Sound Pressure	High / Low*4)	dBA	36 / 28	38 / 28	
Dimensions	Net Weight		kg	21	21	
	Shipping Weight		kg	25	25	
	Net Dimensions (WxHxD)		mm	890 x 230 x 575	890 x 230 x 575	
	Shipping Dimensions (WxHxD)		mm	1,077 x 299 x 642	1,077 x 299 x 642	
Panel Size	Panel model		-	P2SMA	P2SMA	
	Panel Net Weight		kg	4.0	4.0	
	Shipping Weight		kg	8.0	8.0	
	Net Dimensions (WxHxD)		mm	1,030 x 25 x 650	1,030 x 25 x 650	
	Shipping Dimensions (WxHxD)		mm	1,103 x 151 x 727	1,103 x 151 x 727	
Additional Accessories	Drain pump	Drain pump	- / Model	Built-in	Built-in	
		Max. lifting Height / Displacement	mm/liter/h	750 / 24	750 / 24	
	Air Filter		-		Long life filter	Long life filter

* Specifications may be subject to change without prior notice for product improvement.

*1) Mode

- HP : Heat Pump, HR : Heat Recovery

*2) Nominal cooling capacities are based on;

- Indoor temperature : 27°C DB, 19°C WB

- Outdoor temperature : 35°C DB, 24°C WB, Equivalent refrigerant piping : 7.5m, Level differences : 0m

*3) Nominal heating capacities are based on;

- Indoor temperature : 20°C DB, 15°C WB

- Outdoor temperature : 7°C DB, 6°C WB, Equivalent refrigerant piping : 7.5m, Level differences : 0m

*4) Sound pressure was acquired in a dead room. Thus actual noise level may be different depending on the installation conditions.

2-2. Capacity tables

1) Cooling

TC : Total Capacity(kW), SHC : Sensible Heat Capacity(kW)

Model	Outdoor temperature (°C, DB)	Indoor temperature (°C, WB)													
		20 (°C, DB)		23 (°C, DB)		26 (°C, DB)		27 (°C, DB)		28 (°C, DB)		30 (°C, DB)		32 (°C, DB)	
		14 (°C, WB)		16 (°C, WB)		18 (°C, WB)		19 (°C, WB)		20 (°C, WB)		22 (°C, WB)		24 (°C, WB)	
		TC	SHC	TC	SHC	TC	SHC	TC	SHC	TC	SHC	TC	SHC	TC	SHC
056	10	3.9	3.1	4.6	3.4	5.3	3.8	5.6	3.8	5.8	3.8	6.3	3.8	6.7	3.7
	12	3.9	3.1	4.6	3.4	5.3	3.8	5.6	3.8	5.8	3.8	6.3	3.8	6.7	3.7
	14	3.9	3.1	4.6	3.4	5.3	3.8	5.6	3.8	5.8	3.8	6.2	3.8	6.7	3.7
	16	3.9	3.1	4.6	3.4	5.3	3.8	5.6	3.8	5.8	3.8	6.2	3.8	6.6	3.6
	18	3.9	3.1	4.6	3.4	5.3	3.8	5.6	3.8	5.8	3.8	6.2	3.8	6.6	3.6
	20	3.9	3.1	4.6	3.4	5.3	3.8	5.6	3.8	5.8	3.8	6.2	3.8	6.6	3.6
	21	3.9	3.1	4.6	3.4	5.3	3.8	5.6	3.8	5.8	3.8	6.2	3.8	6.6	3.6
	23	3.9	3.1	4.6	3.4	5.3	3.8	5.6	3.8	5.8	3.8	6.2	3.8	6.6	3.6
	25	3.9	3.1	4.6	3.4	5.3	3.8	5.6	3.8	5.8	3.8	6.2	3.8	6.6	3.6
	27	3.9	3.1	4.6	3.4	5.3	3.8	5.6	3.8	5.8	3.8	6.2	3.8	6.6	3.6
	29	3.9	3.1	4.6	3.4	5.3	3.8	5.6	3.8	5.8	3.8	6.2	3.8	6.6	3.6
	31	3.9	3.1	4.6	3.4	5.3	3.8	5.6	3.8	5.8	3.8	6.2	3.8	6.6	3.6
	33	3.9	3.1	4.6	3.4	5.3	3.8	5.6	3.8	5.8	3.8	6.2	3.8	6.6	3.6
	35	3.9	3.1	4.6	3.4	5.3	3.8	5.6	3.8	5.8	3.8	6.2	3.8	6.6	3.6
	37	3.9	3.1	4.6	3.4	5.3	3.8	5.6	3.8	5.8	3.8	6.1	3.7	6.5	3.5
	39	3.9	3.1	4.6	3.4	5.3	3.8	5.6	3.8	5.8	3.8	6.1	3.7	6.4	3.4
42	3.9	3.1	4.6	3.4	5.3	3.8	5.4	3.7	5.6	3.7	5.8	3.6	6.0	3.2	
44	3.9	3.1	4.6	3.4	5.0	3.7	5.3	3.6	5.4	3.6	5.5	3.5	5.6	3.0	
071	10	4.9	4.0	5.8	4.4	6.7	4.9	7.1	5.1	7.4	5.0	8.0	5.1	8.5	4.8
	12	4.9	4.0	5.8	4.4	6.7	4.9	7.1	5.1	7.4	5.0	7.9	5.0	8.5	4.8
	14	4.9	4.0	5.8	4.4	6.7	4.9	7.1	5.1	7.4	5.0	7.9	5.0	8.5	4.8
	16	4.9	4.0	5.8	4.4	6.7	4.9	7.1	5.1	7.4	5.0	7.9	5.0	8.4	4.7
	18	4.9	4.0	5.8	4.4	6.7	4.9	7.1	5.1	7.4	5.0	7.9	5.0	8.4	4.7
	20	4.9	4.0	5.8	4.4	6.7	4.9	7.1	5.1	7.4	5.0	7.9	5.0	8.4	4.7
	21	4.9	4.0	5.8	4.4	6.7	4.9	7.1	5.1	7.4	5.0	7.9	5.0	8.4	4.7
	23	4.9	4.0	5.8	4.4	6.7	4.9	7.1	5.1	7.4	5.0	7.9	5.0	8.4	4.7
	25	4.9	4.0	5.8	4.4	6.7	4.9	7.1	5.1	7.4	5.0	7.9	5.0	8.4	4.7
	27	4.9	4.0	5.8	4.4	6.7	4.9	7.1	5.1	7.4	5.0	7.9	5.0	8.4	4.7
	29	4.9	4.0	5.8	4.4	6.7	4.9	7.1	5.1	7.4	5.0	7.9	5.0	8.4	4.7
	31	4.9	4.0	5.8	4.4	6.7	4.9	7.1	5.1	7.4	5.0	7.9	5.0	8.4	4.7
	33	4.9	4.0	5.8	4.4	6.7	4.9	7.1	5.1	7.4	5.0	7.9	5.0	8.4	4.7
	35	4.9	4.0	5.8	4.4	6.7	4.9	7.1	5.1	7.4	5.0	7.9	5.0	8.4	4.7
	37	4.9	4.0	5.8	4.4	6.7	4.9	7.1	5.1	7.3	4.9	7.8	4.9	8.2	4.6
	39	4.9	4.0	5.8	4.4	6.7	4.9	7.1	5.1	7.3	4.9	7.7	4.8	8.1	4.5
42	4.9	4.0	5.8	4.4	6.7	4.9	6.9	4.9	7.0	4.7	7.3	4.5	7.6	4.3	
44	4.9	4.0	5.8	4.4	6.3	4.7	6.7	4.8	6.8	4.6	7.0	4.4	7.1	4.1	

Indoor units

2) Heating

TC : Total Capacity(kW)

Model	Outdoor temperature (°C)		Indoor temperature (°C, DB)				
			16.0	18.0	20.0	22.0	24.0
			TC	TC	TC	TC	TC
	DB	WB	kW	kW	kW	kW	kW
056	-20	-21	3.9	3.8	3.8	3.7	3.7
	-17	-18	4.0	4.0	3.9	3.8	3.8
	-15	-16	4.2	4.1	4.0	3.9	3.8
	-12	-13	4.4	4.3	4.2	4.2	4.1
	-10	-11	4.6	4.6	4.5	4.4	4.4
	-7	-8	4.9	4.8	4.8	4.7	4.5
	-5	-6	5.2	5.1	5.0	4.9	4.7
	-3	-4	5.4	5.3	5.3	5.1	4.9
	0	-1	5.7	5.6	5.5	5.3	5.0
	3	2.2	5.9	5.9	5.8	5.6	5.3
	5	4.1	6.2	6.1	6.0	5.7	5.3
	7	6	6.5	6.4	6.3	5.8	5.3
	9	7.9	6.7	6.5	6.3	5.8	5.3
	11	9.8	6.9	6.6	6.3	5.8	5.3
	13	12	7.1	6.7	6.3	5.8	5.3
	15	14	7.3	6.8	6.3	5.8	5.3
071	-20	-21	4.9	4.9	4.8	4.7	4.7
	-17	-18	5.1	5.0	4.9	4.8	4.8
	-15	-16	5.3	5.2	5.1	4.9	4.8
	-12	-13	5.6	5.5	5.4	5.3	5.2
	-10	-11	5.9	5.8	5.7	5.6	5.6
	-7	-8	6.2	6.1	6.0	5.9	5.8
	-5	-6	6.5	6.5	6.4	6.2	6.0
	-3	-4	6.9	6.8	6.7	6.4	6.2
	0	-1	7.2	7.1	7.0	6.7	6.4
	3	2.2	7.6	7.5	7.3	7.1	6.8
	5	4.1	7.9	7.8	7.7	7.2	6.8
	7	6	8.2	8.1	8.0	7.4	6.8
	9	7.9	8.5	8.2	8.0	7.4	6.8
	11	9.8	8.7	8.4	8.0	7.4	6.8
	13	12	9.0	8.5	8.0	7.4	6.8
	15	14	9.2	8.6	8.0	7.4	6.8

2 2 way cassette

2-3. Dimensional drawing

Unit:mm

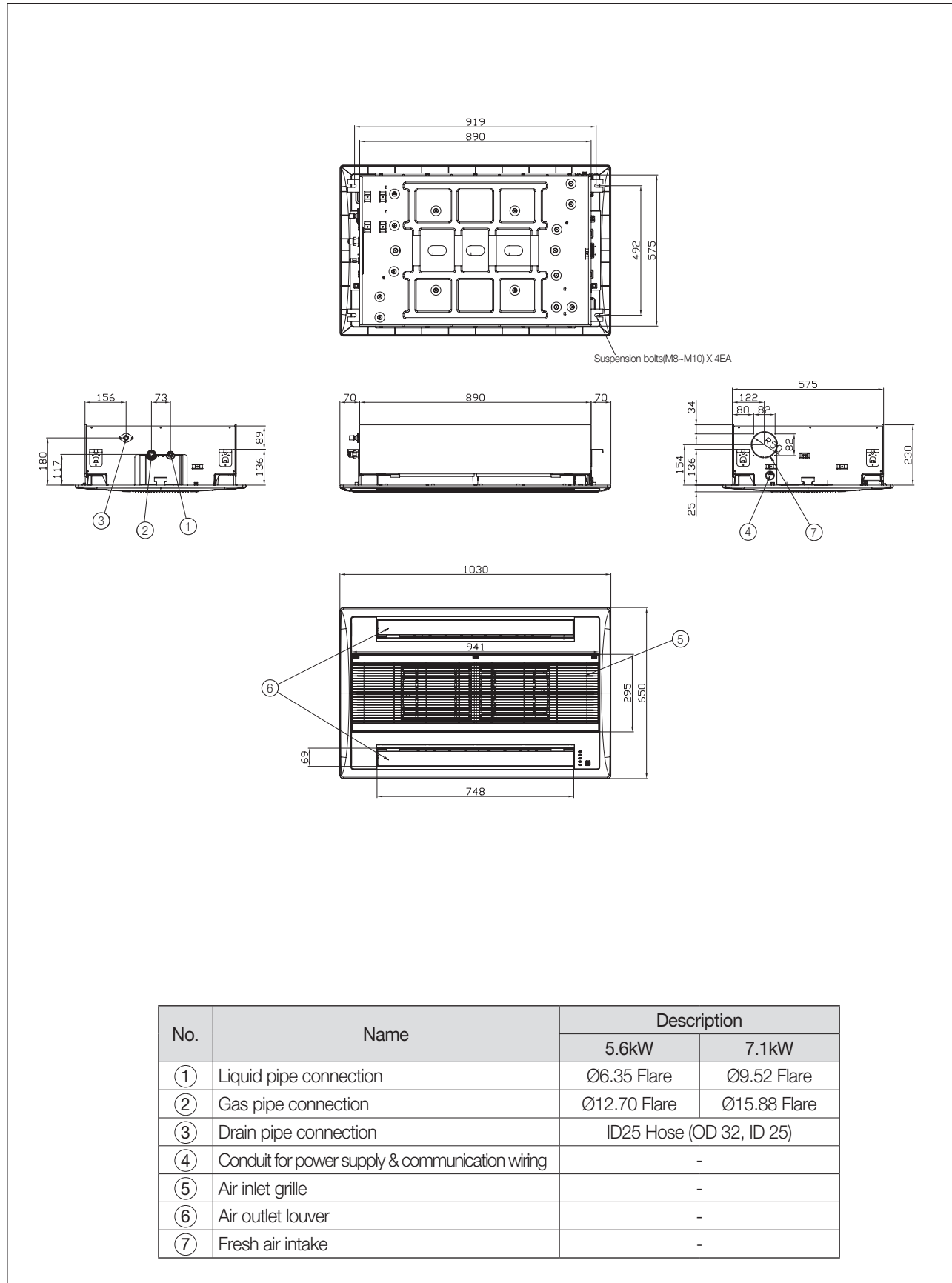

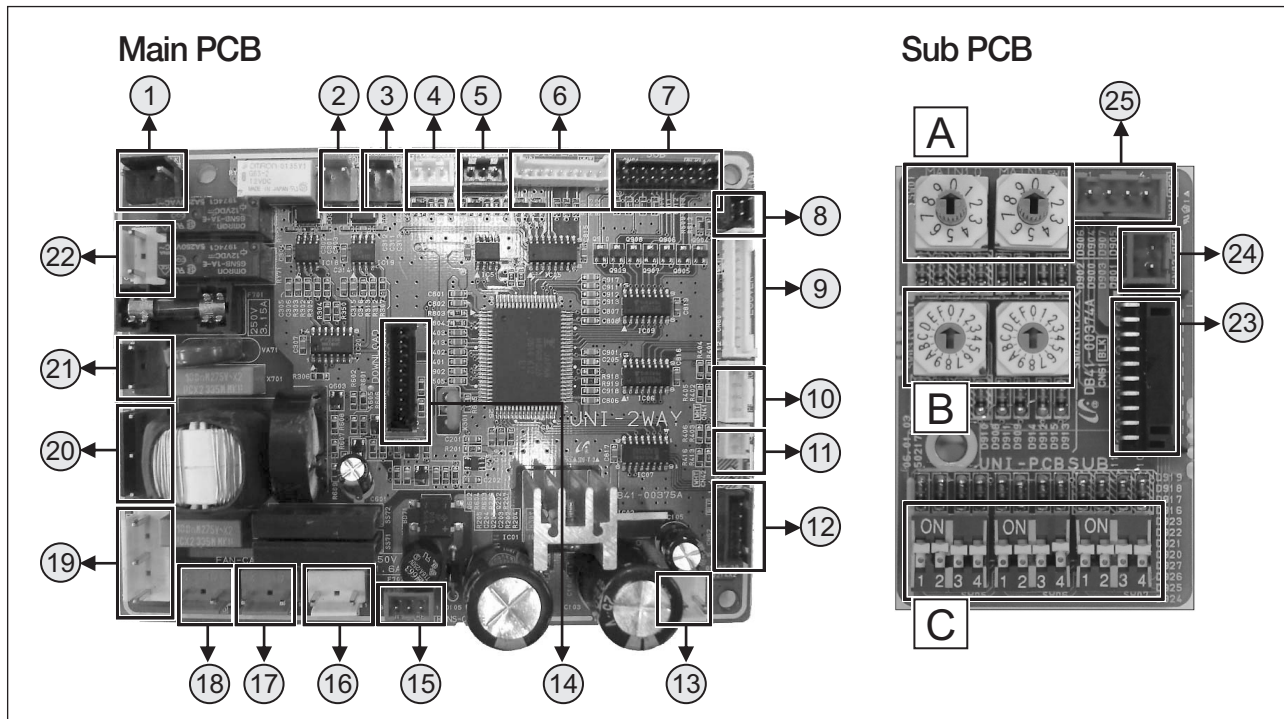

2-4. PCB Connector Lay-out



Indoor units

Main PCB			
No.	CN #	COLOR	FUNCTION
①	CN75	Black	Ventilator
②	CN31	Red	Communication with Outdoor Units (COM1)
③	CN33	Blue	Communication with Wired Remote Controller (COM2)
④	CN52	White	Hall IC1
⑤	CN44	Blue	Hall IC2
⑥	CN91	White	Display
⑦	CN61	Black	Main-Sub PCB connector
⑧	CN51	Black	Float Switch
⑨	CN60	White	Louver
⑩	CN41	White	Room Sensor, Eva-In Sensor
⑪	CN42	White	Eva-Out Sensor
⑫	CN62	Blue	EEV
⑬	CN32	White	DC 12V for Wired Remote Controller
⑭	CN10	Black	MICOM Download
⑮	CN11	Red	Trans-Out (AC 17V)
⑯	CN72	White	Trans-In (AC 230V)
⑰	CN45	Red	Fan Capacitor
⑱	CN73	White	Fan Motor1
⑳	CN78	Blue	Fan Motor2
㉑	CN71	Blue	AC 230V Input
㉒	CN74	Yellow	Drain Pump

Sub PCB			
No.	CN #	COLOR	FUNCTION
㉓	CN61	Black	Main-Sub PCB connector
㉔	CN83	Red	External Contact Control
㉕	CN81	Red	Error Check, Indoor unit Operation

No.	S/W	FUNCTION	
A	 SW01 SW02	Main Address (00~63)	
B	 SW03 SW04	SW03	SW04
		Address of Interface Module Channel 0~2	Group Address (RMC) for Centralized Control 0~F

No.	S/W	FUNCTION	ON	OFF
	K1	-	-	-
	K2	Centralized Controller	Not use	Use
	K3	RPM Up	N/A	N/A
	K4	Optional Drain Pump	N/A	N/A
	K5	Heating Thermo-off	+2°C	+5°C
	K6	Filter Signal Display	1,000hrs	2,000hrs
	K7	Hot Water Coil	N/A	N/A
	K8	Electrical Heater	N/A	N/A
	K9	Min. EEV Step at Heating	Fixed 80 step	0 or 80 step
	K10	Priority of Indoor unit Display on Wired Remote Control	Slave (Default)	Master
	K11	External Contact Control	Not use	Use
	K12	-	-	-

2 way cassette

2-5. Electrical wiring diagram

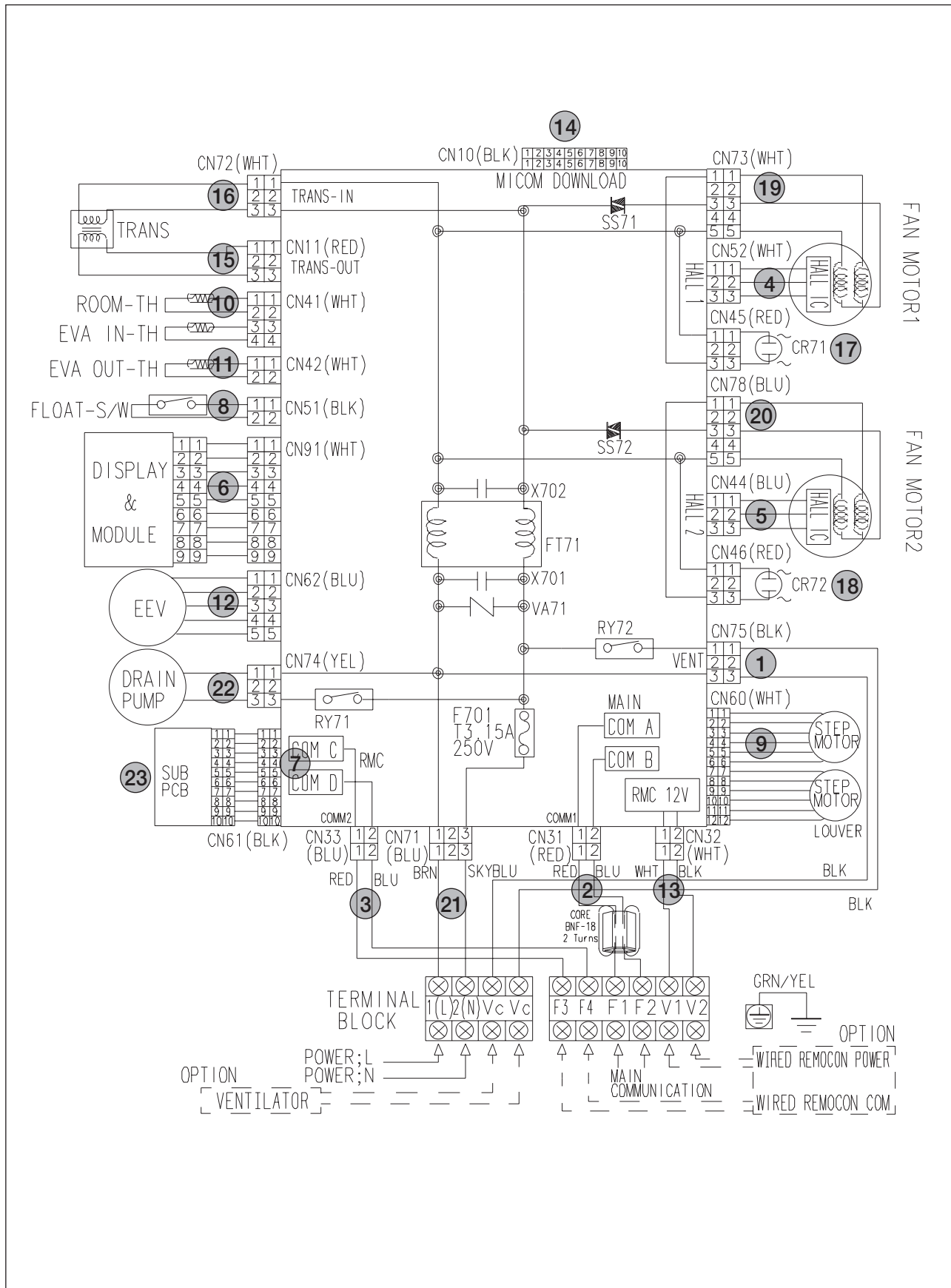

2-6. Sound pressure level

1) Operation sound level

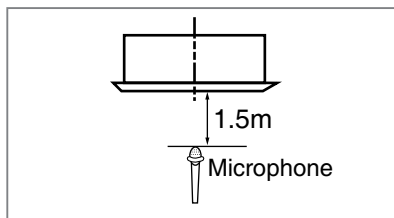

Unit : dB(A)

Model	High	Low
AVXC2H056E*	36	28
AVXC2H071E*	38	28

Note

- ◆ These operation values were obtained in a dead room. Sound pressure level will vary depending on a range of factors such as the construction of the particular room where the equipment is installed.
- ◆ Operation sound level may differ depending on operation and ambient conditions.

2) NC curves

(1) AVXC2H056E*

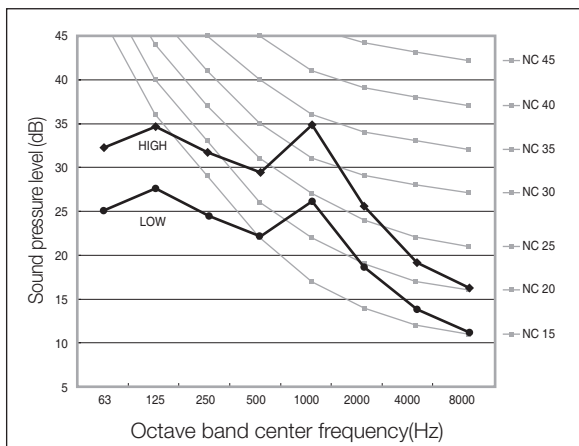

(2) AVXC2H071E*

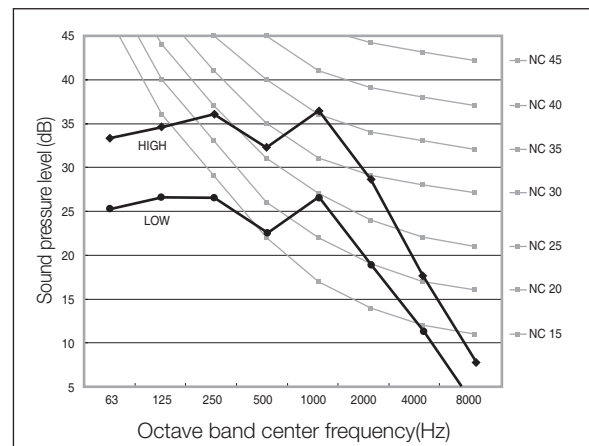

2-7. Temperature and air flow distribution

1) AVXC2H071E*

(1) Cooling air velocity distribution

◆ Discharge angle : 54°

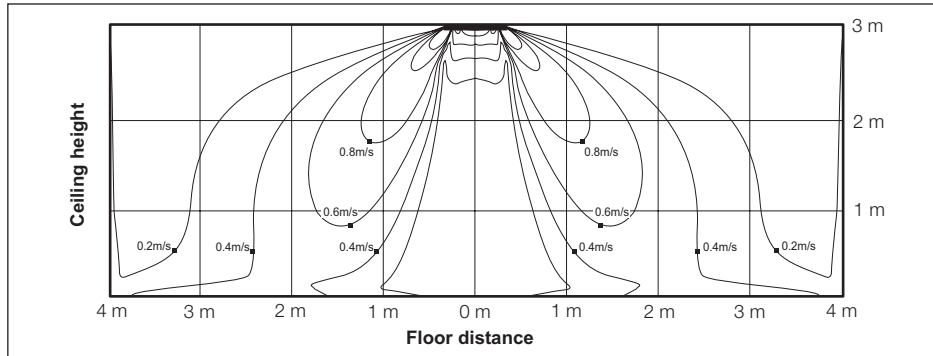

(2) Cooling temperature distribution

◆ Discharge angle : 54°

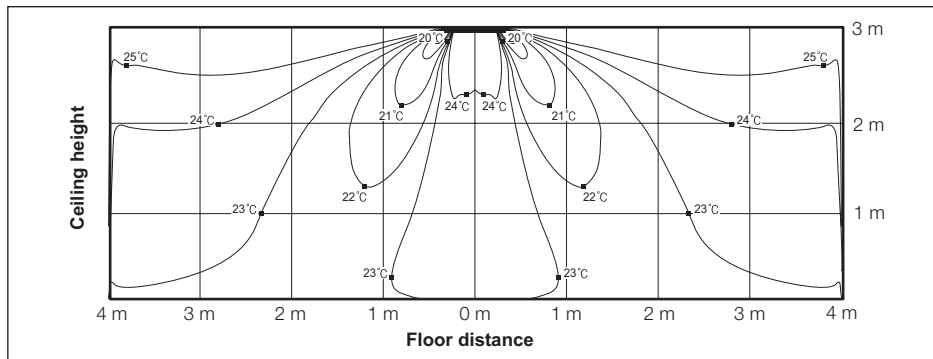

(3) Heating air velocity distribution

◆ Discharge angle : 54°

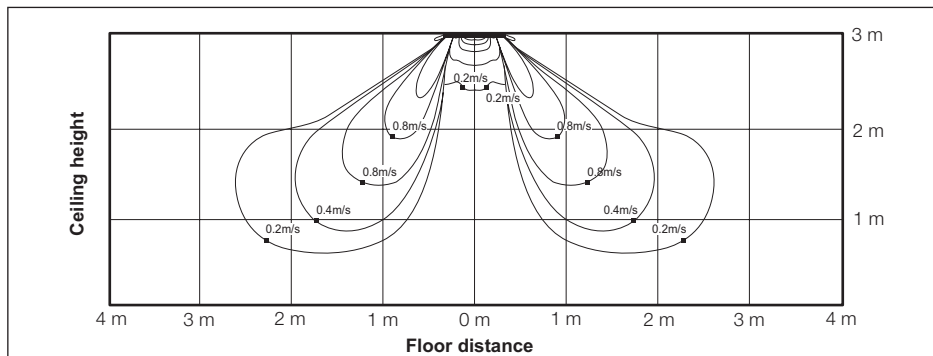

(4) Heating temperature distribution

◆ Discharge angle : 54°

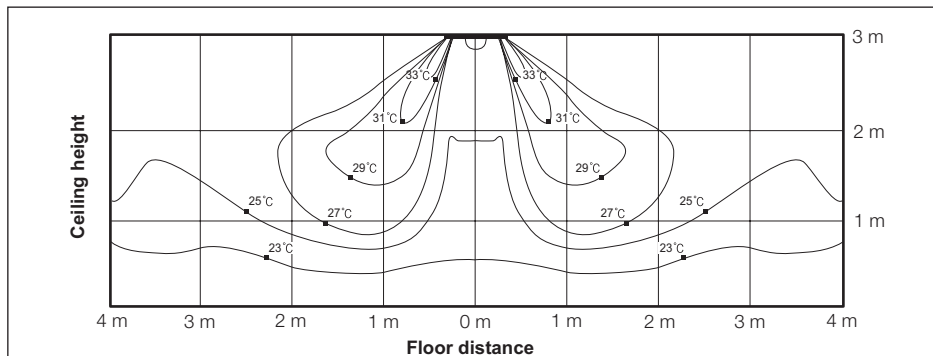



3 Mini 4 way cassette (AVXCMH***E*)

3-1. Specifications.....	36
3-2. Capacity tables	37
3-3. Dimensional drawing.....	39
3-4. PCB connector lay-out.....	40
3-5. Electrical wiring diagram	41
3-6. Sound pressure level	42
3-7. Temperature and air flow distribution.....	43

Optional Accessories

Individual Controllers



MWR-WE10



MWR-WH00



MWR-SH00



MR-DH00

Panel



PMSMA

3 Mini 4 way cassette

3-1. Specifications

1) Technical specifications

Model			AVXCMH028E*	AVXCMH036E*	AVXCMH056E*	AVXCMH060E*	
Power Supply			Ø, #, V, Hz	1, 2, 220-240, 50	1, 2, 220-240, 50	1, 2, 220-240, 50	1, 2, 220-240, 50
Mode*1)			-	HP / HR	HP / HR	HP / HR	HP / HR
Capacity (Nominal)	Cooling*2)	kW	2.8	3.6	5.6	6.0	
		Btu/h	9,600	12,300	19,100	20,500	
	Heating*3)	kW	3.2	4.0	6.3	6.8	
		Btu/h	10,900	13,600	21,500	23,200	
Power	Power Input (Nominal)	Cooling*2)	W	90	90	95	100
		Heating*3)	W	90	90	95	100
	Current Input (Nominal)	Cooling*2)	A	0.50	0.50	0.52	0.55
		Heating*3)	A	0.50	0.50	0.52	0.55
Fan	Motor	Type	-	Turbo Fan / SSR	Turbo Fan / SSR	Turbo Fan / SSR	Turbo Fan / SSR
		Output	W	80	80	80	80
		Number of unit	EA	1	1	1	1
	Air Flow Rate	H/M/L (UL)	CMM	10.1 / 9.1 / 8.1	10.3 / 9.3 / 8.3	13 / 12 / 11	13.5 / 12.5 / 11.5
			CFM	360 / 320 / 290	360 / 330 / 290	460 / 420 / 390	480 / 440 / 410
	External Pressure	Min / Std / Max	mmAq	-	-	-	-
			Pa	-	-	-	-
			WG	-	-	-	-
Option Code			-	045223-14414C-200000-300000	045223-16414C-200000-300000	045223-19416E-200000-300000	045224-1B40C3-200000-300000
Piping Connections	Liquid Pipe	Ø, mm	6.35	6.35	6.35	6.35	
		Ø, inch	1/4	1/4	1/4	1/4	
	Gas Pipe	Ø, mm	12.7	12.7	12.7	12.7	
		Ø, inch	1/2	1/2	1/2	1/2	
Drain Pipe	Ø, mm	ID25 Hose (OD 32, ID 25)	ID25 Hose (OD 32, ID 25)	ID25 Hose (OD 32, ID 25)	ID25 Hose (OD 32, ID 25)		
Field Wiring	Power Source Wire	Below 20m / over 20m	mm ²	1.5 / 2.5	1.5 / 2.5	1.5 / 2.5	
	Transmission Cable	mm ²	0.75 / 1.5	0.75 / 1.5	0.75 / 1.5	0.75 / 1.5	
Refrigerant	Type	-	R410A	R410A	R410A	R410A	
	Control Method	-	EEV	EEV	EEV	EEV	
Sound	Sound Pressure	High / Low*4)	dB(A)	30 / 25	34 / 27	41 / 33	41 / 33
Dimensions	Net Weight		kg	17	17	17	17
	Shipping Weight		kg	20	20	20	20
	Net Dimensions (WxHxD)		mm	575 x 260 x 575	575 x 260 x 575	575 x 260 x 575	575 x 260 x 575
	Shipping Dimensions (WxHxD)		mm	660 x 310 x 635	660 x 310 x 635	660 x 310 x 635	660 x 310 x 635
Panel Size	Panel model		-	PMSMA	PMSMA	PMSMA	PMSMA
	Panel Net Weight		kg	3.5	3.5	3.5	3.5
	Shipping Weight		kg	6.2	6.2	6.2	6.2
	Net Dimensions (WxHxD)		mm	670 x 35 x 670	670 x 35 x 670	670 x 35 x 670	670 x 35 x 670
	Shipping Dimensions (WxHxD)		mm	717 x 93 x 717	717 x 93 x 717	717 x 93 x 717	717 x 93 x 717
Additional Accessories	Drain pump	Drain pump	- / Model	Built-in	Built-in	Built-in	Built-in
		Max. lifting Height / Displacement	mm/liter/h	750 / 24	750 / 24	750 / 24	750 / 24
	Air Filter		-	Long life filter	Long life filter	Long life filter	Long life filter

* Specifications may be subject to change without prior notice for product improvement.

*1) Mode

- HP : Heat Pump, HR : Heat Recovery

*2) Nominal cooling capacities are based on;

- Indoor temperature : 27°C DB, 19°C WB

- Outdoor temperature : 35°C DB, 24°C WB, Equivalent refrigerant piping : 7.5m, Level differences : 0m

*3) Nominal heating capacities are based on;

- Indoor temperature : 20°C DB, 15°C WB

- Outdoor temperature : 7°C DB, 6°C WB, Equivalent refrigerant piping : 7.5m, Level differences : 0m

*4) Sound pressure was acquired in a dead room. Thus actual noise level may be different depending on the installation conditions.

3-2. Capacity tables

1) Cooling

TC : Total Capacity(kW), SHC : Sensible Heat Capacity(kW)

Model	Outdoor temperature (°C, DB)	Indoor temperature (°C, WB)													
		20 (°C, DB) 14 (°C, WB)		23 (°C, DB) 16 (°C, WB)		26 (°C, DB) 18 (°C, WB)		27 (°C, DB) 19 (°C, WB)		28 (°C, DB) 20 (°C, WB)		30 (°C, DB) 22 (°C, WB)		32 (°C, DB) 24 (°C, WB)	
		TC	SHC	TC	SHC	TC	SHC	TC	SHC	TC	SHC	TC	SHC	TC	SHC
028	10	1.9	1.7	2.3	1.8	2.6	2.0	2.8	2.0	2.9	2.0	3.1	2.0	3.4	1.9
	12	1.9	2.0	2.3	2.1	2.6	2.0	2.8	2.0	2.9	2.0	3.1	2.0	3.3	1.8
	14	1.9	2.0	2.3	2.1	2.6	2.0	2.8	2.0	2.9	2.0	3.1	2.0	3.3	1.8
	16	1.9	2.0	2.3	2.1	2.6	2.0	2.8	2.0	2.9	2.0	3.1	2.0	3.3	1.8
	18	1.9	2.0	2.3	2.1	2.6	2.0	2.8	2.0	2.9	2.0	3.1	2.0	3.3	1.8
	20	1.9	2.0	2.3	2.1	2.6	2.0	2.8	2.0	2.9	2.0	3.1	2.0	3.3	1.8
	21	1.9	2.0	2.3	2.1	2.6	2.0	2.8	2.0	2.9	2.0	3.1	2.0	3.3	1.8
	23	1.9	2.0	2.3	2.1	2.6	2.0	2.8	2.0	2.9	2.0	3.1	2.0	3.3	1.8
	25	1.9	2.0	2.3	2.1	2.6	2.0	2.8	2.0	2.9	2.0	3.1	2.0	3.3	1.8
	27	1.9	2.0	2.3	2.1	2.6	2.0	2.8	2.0	2.9	2.0	3.1	2.0	3.3	1.8
	29	1.9	2.0	2.3	2.1	2.6	2.0	2.8	2.0	2.9	2.0	3.1	2.0	3.3	1.8
	31	1.9	2.0	2.3	2.1	2.6	2.0	2.8	2.0	2.9	2.0	3.1	2.0	3.3	1.8
	33	1.9	2.0	2.3	2.1	2.6	2.0	2.8	2.0	2.9	2.0	3.1	2.0	3.3	1.8
	35	1.9	2.0	2.3	2.1	2.6	2.0	2.8	2.0	2.9	2.0	3.1	2.0	3.3	1.8
	37	1.9	2.0	2.3	2.1	2.6	2.0	2.8	2.0	2.9	2.0	3.1	2.0	3.3	1.8
39	1.9	2.0	2.3	2.1	2.6	2.0	2.8	2.0	2.9	1.9	3.0	1.9	3.2	1.8	
42	1.9	2.0	2.3	2.1	2.6	2.0	2.7	1.9	2.8	1.9	2.9	1.8	3.0	1.7	
44	1.9	2.0	2.3	2.1	2.5	1.9	2.7	1.9	2.7	1.8	2.7	1.7	2.8	1.6	
036	10	2.5	2.1	2.9	2.2	3.4	2.4	3.6	2.5	3.7	2.5	4.0	2.5	4.3	2.3
	12	2.5	2.1	2.9	2.2	3.4	2.4	3.6	2.5	3.7	2.5	4.0	2.5	4.3	2.3
	14	2.5	2.1	2.9	2.2	3.4	2.4	3.6	2.5	3.7	2.5	4.0	2.5	4.3	2.3
	16	2.5	2.1	2.9	2.2	3.4	2.4	3.6	2.5	3.7	2.5	4.0	2.5	4.3	2.3
	18	2.5	2.1	2.9	2.2	3.4	2.4	3.6	2.5	3.7	2.5	4.0	2.5	4.3	2.3
	20	2.5	2.1	2.9	2.2	3.4	2.4	3.6	2.5	3.7	2.5	4.0	2.5	4.2	2.3
	21	2.5	2.1	2.9	2.2	3.4	2.4	3.6	2.5	3.7	2.5	4.0	2.5	4.2	2.3
	23	2.5	2.1	2.9	2.2	3.4	2.4	3.6	2.5	3.7	2.5	4.0	2.5	4.2	2.3
	25	2.5	2.1	2.9	2.2	3.4	2.4	3.6	2.5	3.7	2.5	4.0	2.5	4.2	2.3
	27	2.5	2.1	2.9	2.2	3.4	2.4	3.6	2.5	3.7	2.5	4.0	2.5	4.2	2.3
	29	2.5	2.1	2.9	2.2	3.4	2.4	3.6	2.5	3.7	2.5	4.0	2.5	4.2	2.3
	31	2.5	2.1	2.9	2.2	3.4	2.4	3.6	2.5	3.7	2.5	4.0	2.5	4.2	2.3
	33	2.5	2.1	2.9	2.2	3.4	2.4	3.6	2.5	3.7	2.5	4.0	2.5	4.2	2.3
	35	2.5	2.1	2.9	2.2	3.4	2.4	3.6	2.5	3.7	2.5	4.0	2.5	4.2	2.3
	37	2.5	2.1	2.9	2.2	3.4	2.4	3.6	2.5	3.7	2.5	3.9	2.4	4.2	2.3
39	2.5	2.1	2.9	2.2	3.4	2.4	3.6	2.5	3.7	2.5	3.9	2.4	4.1	2.2	
42	2.5	2.1	2.9	2.2	3.4	2.4	3.5	2.4	3.6	2.4	3.7	2.3	3.9	2.1	
44	2.5	2.1	2.9	2.2	3.2	2.3	3.4	2.3	3.5	2.3	3.5	2.2	3.6	2.0	
056	10	3.9	3.3	4.6	3.8	5.3	4.1	5.6	4.2	5.8	4.2	6.3	4.3	6.7	4.1
	12	3.9	3.3	4.6	3.8	5.3	4.1	5.6	4.2	5.8	4.2	6.3	4.3	6.7	4.1
	14	3.9	3.3	4.6	3.8	5.3	4.1	5.6	4.2	5.8	4.2	6.2	4.2	6.6	4.0
	16	3.9	3.3	4.6	3.8	5.3	4.1	5.6	4.2	5.8	4.2	6.2	4.2	6.6	4.0
	18	3.9	3.3	4.6	3.8	5.3	4.1	5.6	4.2	5.8	4.2	6.2	4.2	6.6	4.0
	20	3.9	3.3	4.6	3.8	5.3	4.1	5.6	4.2	5.8	4.2	6.2	4.2	6.6	4.0
	21	3.9	3.3	4.6	3.8	5.3	4.1	5.6	4.2	5.8	4.2	6.2	4.2	6.6	4.0
	23	3.9	3.3	4.6	3.8	5.3	4.1	5.6	4.2	5.8	4.2	6.2	4.2	6.6	4.0
	25	3.9	3.3	4.6	3.8	5.3	4.1	5.6	4.2	5.8	4.2	6.2	4.2	6.6	4.0
	27	3.9	3.3	4.6	3.8	5.3	4.1	5.6	4.2	5.8	4.2	6.2	4.2	6.6	4.0
	29	3.9	3.3	4.6	3.8	5.3	4.1	5.6	4.2	5.8	4.2	6.2	4.2	6.6	4.0
	31	3.9	3.3	4.6	3.8	5.3	4.1	5.6	4.2	5.8	4.2	6.2	4.2	6.6	4.0
	33	3.9	3.3	4.6	3.8	5.3	4.1	5.6	4.2	5.8	4.2	6.2	4.2	6.6	4.0
	35	3.9	3.3	4.6	3.8	5.3	4.1	5.6	4.2	5.8	4.2	6.2	4.2	6.6	4.0
	37	3.9	3.3	4.6	3.8	5.3	4.1	5.6	4.2	5.8	4.2	6.1	4.1	6.5	3.9
39	3.9	3.3	4.6	3.8	5.3	4.1	5.6	4.2	5.8	4.2	6.1	4.1	6.4	3.8	
42	3.9	3.3	4.6	3.8	5.3	4.1	5.4	4.1	5.6	4.1	5.8	3.9	6.0	3.6	
44	3.9	3.3	4.6	3.8	5.0	4.0	5.3	4.0	5.4	4.0	5.5	3.8	5.6	3.4	
060	10	4.1	3.5	4.9	4.0	5.6	4.5	6.0	4.5	6.2	4.5	6.7	4.6	7.2	4.4
	12	4.1	3.5	4.9	4.0	5.6	4.5	6.0	4.5	6.2	4.5	6.7	4.6	7.2	4.4
	14	4.1	3.5	4.9	4.0	5.6	4.5	6.0	4.5	6.2	4.5	6.7	4.6	7.1	4.3
	16	4.1	3.5	4.9	4.0	5.6	4.5	6.0	4.5	6.2	4.5	6.7	4.6	7.1	4.3
	18	4.1	3.5	4.9	4.0	5.6	4.5	6.0	4.5	6.2	4.5	6.7	4.6	7.1	4.3
	20	4.1	3.5	4.9	4.0	5.6	4.5	6.0	4.5	6.2	4.5	6.6	4.5	7.1	4.3
	21	4.1	3.5	4.9	4.0	5.6	4.5	6.0	4.5	6.2	4.5	6.6	4.5	7.1	4.3
	23	4.1	3.5	4.9	4.0	5.6	4.5	6.0	4.5	6.2	4.5	6.6	4.5	7.1	4.3
	25	4.1	3.5	4.9	4.0	5.6	4.5	6.0	4.5	6.2	4.5	6.6	4.5	7.1	4.3
	27	4.1	3.5	4.9	4.0	5.6	4.5	6.0	4.5	6.2	4.5	6.6	4.5	7.1	4.3
	29	4.1	3.5	4.9	4.0	5.6	4.5	6.0	4.5	6.2	4.5	6.6	4.5	7.1	4.3
	31	4.1	3.5	4.9	4.0	5.6	4.5	6.0	4.5	6.2	4.5	6.6	4.5	7.1	4.3
	33	4.1	3.5	4.9	4.0	5.6	4.5	6.0	4.5	6.2	4.5	6.6	4.5	7.1	4.3
	35	4.1	3.5	4.9	4.0	5.6	4.5	6.0	4.5	6.2	4.5	6.6	4.5	7.1	4.3
	37	4.1	3.5	4.9	4.0	5.6	4.5	6.0	4.5	6.2	4.5	6.6	4.5	7.0	4.2
39	4.1	3.5	4.9	4.0	5.6	4.5	6.0	4.5	6.2	4.5	6.5	4.4	6.8	4.1	
42	4.1	3.5	4.9	4.0	5.6	4.5	5.8	4.4	6.1	4.4	6.3	4.3	6.4	3.8	
44	4.1	3.5	4.9	4.0	5.4	4.4	5.7	4.3	5.8	4.3	5.9	4.2	6.0	3.6	

Indoor units

3 Mini 4 way cassette

3-2. Capacity tables

2) Heating

TC : Total Capacity(kW)

Model	Outdoor temperature (°C)		Indoor temperature (°C, DB)				
			16.0	18.0	20.0	22.0	24.0
			TC kW	TC kW	TC kW	TC kW	TC kW
028	-20	-21	1.9	1.9	1.9	1.9	1.9
	-17	-18	2.0	2.0	2.0	2.0	1.9
	-15	-16	2.1	2.1	2.0	2.0	1.9
	-12	-13	2.2	2.2	2.2	2.1	2.1
	-10	-11	2.3	2.3	2.3	2.3	2.2
	-7	-8	2.5	2.4	2.4	2.4	2.3
	-5	-6	2.6	2.6	2.5	2.5	2.4
	-3	-4	2.8	2.7	2.7	2.6	2.5
	0	-1	2.9	2.8	2.8	2.7	2.6
	3	2.2	3.0	3.0	2.9	2.8	2.7
	5	4.1	3.2	3.1	3.1	2.9	2.7
	7	6	3.3	3.2	3.2	3.0	2.7
	9	7.9	3.4	3.3	3.2	3.0	2.7
	11	9.8	3.5	3.3	3.2	3.0	2.7
	13	12	3.6	3.4	3.2	3.0	2.7
	15	14	3.7	3.4	3.2	3.0	2.7
036	-20	-21	2.4	2.4	2.3	2.3	2.3
	-17	-18	2.6	2.5	2.4	2.4	2.3
	-15	-16	2.7	2.6	2.5	2.5	2.4
	-12	-13	2.8	2.7	2.7	2.6	2.6
	-10	-11	2.9	2.9	2.9	2.8	2.8
	-7	-8	3.1	3.1	3.0	3.0	2.9
	-5	-6	3.3	3.2	3.2	3.1	3.0
	-3	-4	3.4	3.4	3.3	3.2	3.1
	0	-1	3.6	3.6	3.5	3.4	3.2
	3	2.2	3.8	3.7	3.7	3.5	3.4
	5	4.1	3.9	3.9	3.8	3.6	3.4
	7	6	4.1	4.1	4.0	3.7	3.4
	9	7.9	4.2	4.1	4.0	3.7	3.4
	11	9.8	4.4	4.2	4.0	3.7	3.4
	13	12	4.5	4.2	4.0	3.7	3.4
	15	14	4.6	4.3	4.0	3.7	3.4
056	-20	-21	3.9	3.8	3.8	3.7	3.7
	-17	-18	4.0	4.0	3.9	3.8	3.8
	-15	-16	4.2	4.1	4.0	3.9	3.8
	-12	-13	4.4	4.3	4.2	4.2	4.1
	-10	-11	4.6	4.6	4.5	4.4	4.4
	-7	-8	4.9	4.8	4.8	4.7	4.5
	-5	-6	5.2	5.1	5.0	4.9	4.7
	-3	-4	5.4	5.3	5.3	5.1	4.9
	0	-1	5.7	5.6	5.5	5.3	5.0
	3	2.2	5.9	5.9	5.8	5.6	5.3
	5	4.1	6.2	6.1	6.0	5.7	5.3
	7	6	6.5	6.4	6.3	5.8	5.3
	9	7.9	6.7	6.5	6.3	5.8	5.3
	11	9.8	6.9	6.6	6.3	5.8	5.3
	13	12	7.1	6.7	6.3	5.8	5.3
	15	14	7.3	6.8	6.3	5.8	5.3
060	-20	-21	4.4	4.3	4.2	4.2	4.2
	-17	-18	4.5	4.4	4.3	4.3	4.2
	-15	-16	4.7	4.6	4.4	4.3	4.2
	-12	-13	4.9	4.8	4.7	4.6	4.5
	-10	-11	5.1	5.1	5.0	4.9	4.9
	-7	-8	5.4	5.4	5.3	5.2	5.1
	-5	-6	5.7	5.6	5.6	5.4	5.2
	-3	-4	6.0	5.9	5.9	5.6	5.4
	0	-1	6.3	6.2	6.1	5.9	5.6
	3	2.2	6.6	6.5	6.4	6.2	5.9
	5	4.1	6.9	6.8	6.7	6.3	5.9
	7	6	7.2	7.1	6.8	6.5	5.9
	9	7.9	7.4	7.2	6.8	6.5	5.9
	11	9.8	7.6	7.3	6.8	6.5	5.9
	13	12	7.9	7.4	6.8	6.5	5.9
	15	14	8.1	7.5	6.8	6.5	5.9

3-3. Dimensional drawing

Unit:mm

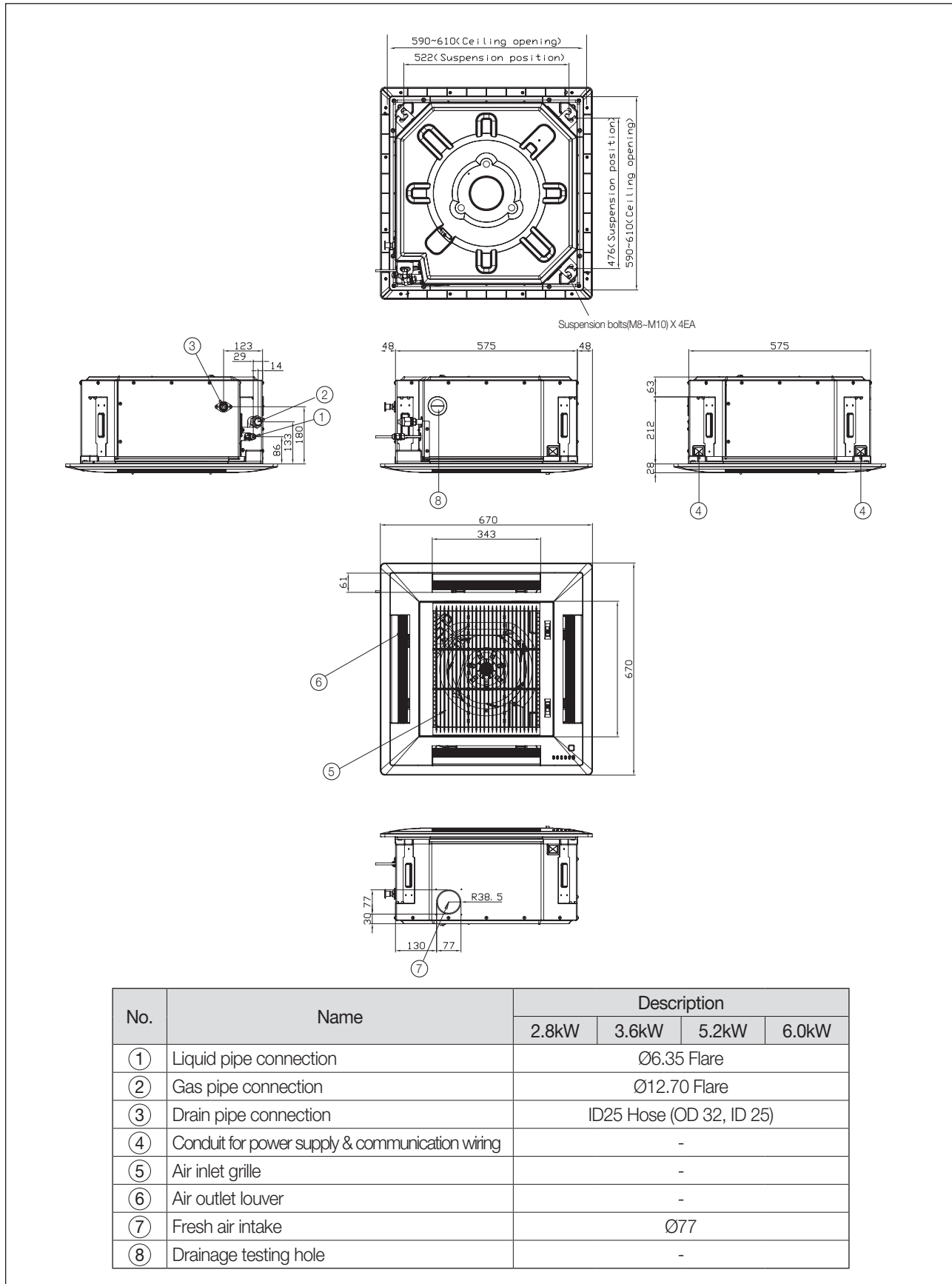

Indoor units

3 Mini 4 way cassette

3-4. PCB connector lay-out

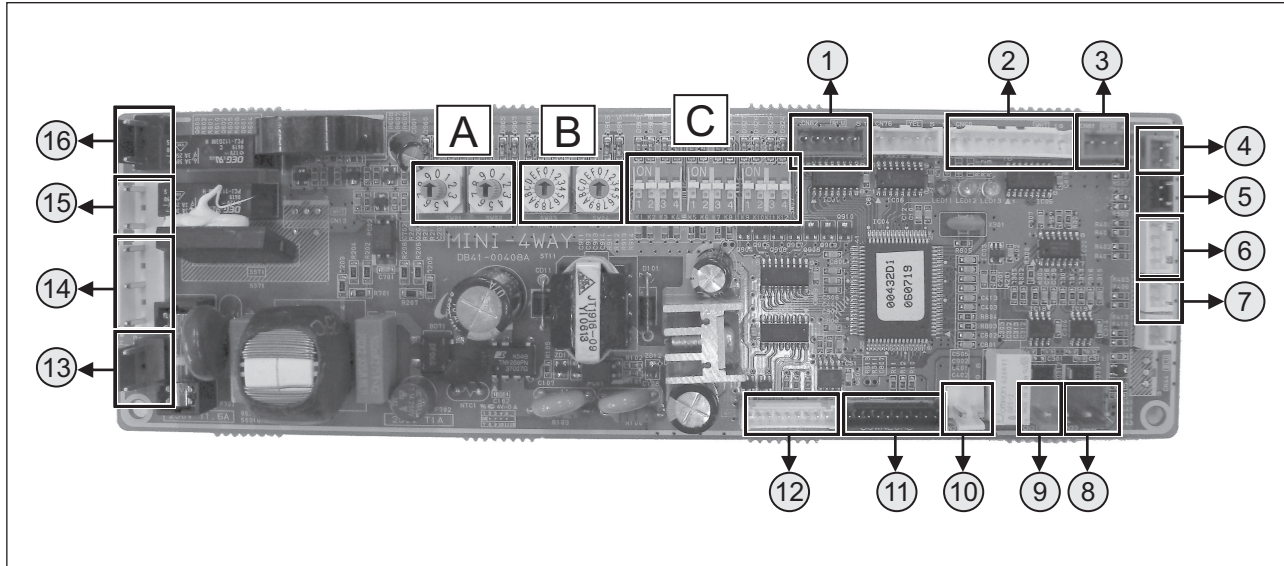

No.	CN #	COLOR	FUNCTION
①	CN62	Blue	EEV
②	CN60	White	Louver
③	CN81	Red	Error Check, Indoor unit Operation
④	CN83	Red	External Contact Control
⑤	CN51	Black	Float Switch
⑥	CN41	White	Room Sensor, Eva-In Sensor
⑦	CN42	White	Eva-Out Sensor
⑧	CN33	Blue	Communication with Wired Remote Controller (COM2)
⑨	CN31	Red	Communication with Outdoor Units (COM1)
⑩	CN32	White	DC12V for Wired Remote Controller
⑪	CN10	Black	MICOM Download
⑫	CN91	White	Display
⑬	CN71	Blue	AC 230V Input
⑭	CN78	White	Fan Motor
⑮	CN74	White	Drain Pump
⑯	CN75	Black	Ventilator

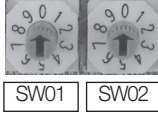
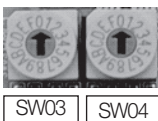
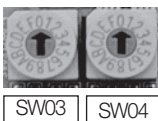
No.	S/W	FUNCTION
A	 SW01 SW02	Main Address (00~63)
	 SW03 SW04	SW03 SW04
B	 SW03 SW04	Address of Interface Module Channel 0~2
		Group Address (RMC) for Centralized Control 0~F

No.	S/W	FUNCTION	ON	OFF
C	K1	-	-	-
	K2	Centralized Controller	Not use	Use
	K3	RPM Up	N/A	N/A
	K4	Optional Drain Pump	N/A	N/A
	K5	Heating Thermo-off	+5°C	+2°C
	K6	Filter Signal Display	1,000hrs	2,000hrs
	K7	Hot Water Coil	N/A	N/A
	K8	Electrical Heater	N/A	N/A
	K9	Min. EEV Step at Heating	Fixed 80 step	0 or 80 step
	K10	Priority of Indoor unit Display on Wired Remote Controlle	Slave (Default)	Master
	K11	External Contact Control	Not use	Use
	K12	-	-	-

3-5 . Electrical wiring diagram

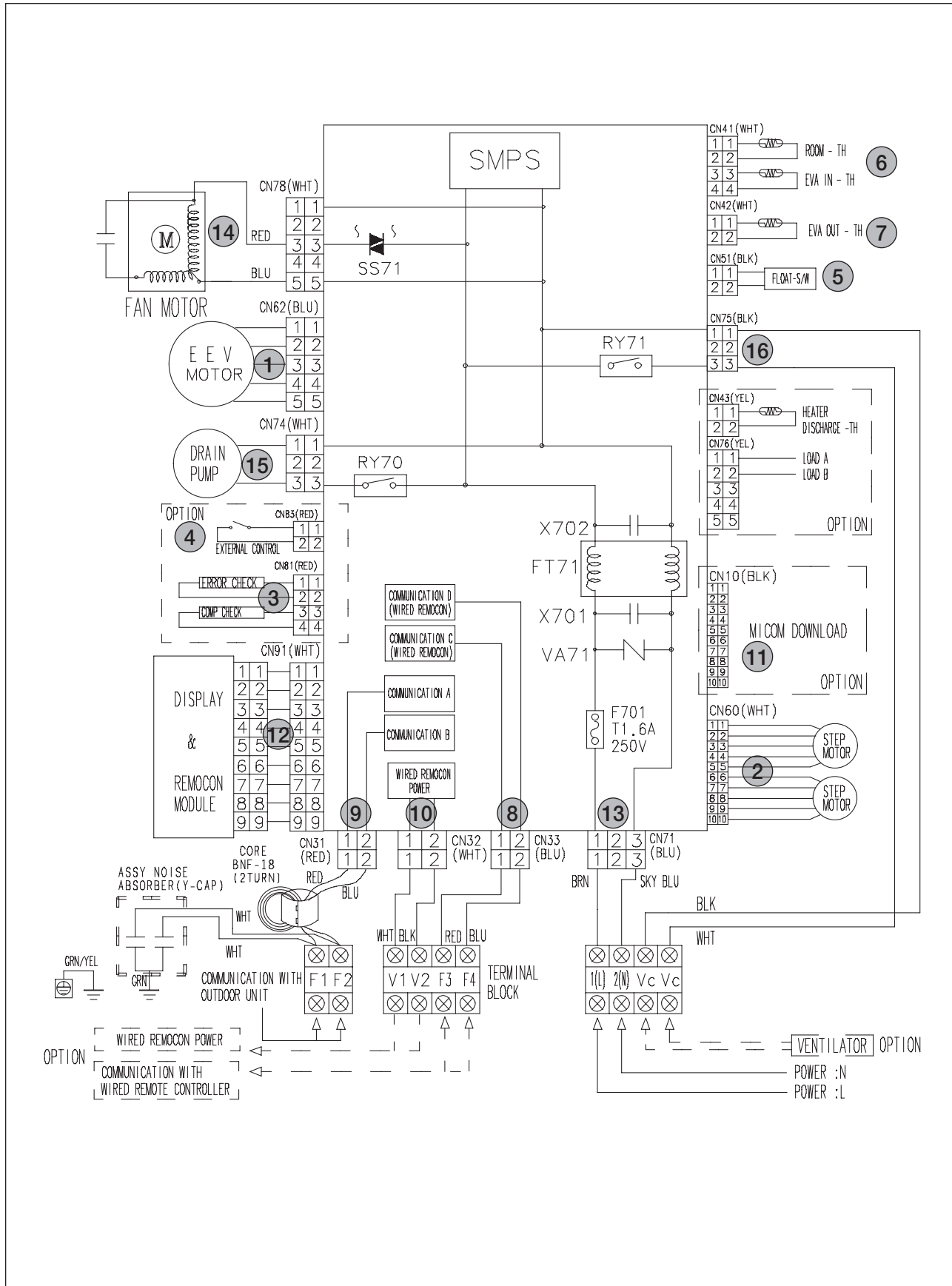

Indoor units

3 Mini 4 way cassette

3-6. Sound pressure level

1) Operation sound level

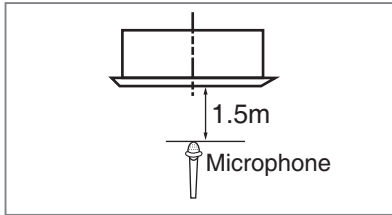

Unit : dB(A)

Model	High	Low
AVXCMH028E*	30	25
AVXCMH036E*	34	27
AVXCMH056E*	41	33
AVXCMH060E*	41	33

✓ Note

- ◆ These operation values were obtained in a dead room. Sound pressure level will vary depending on a range of factors such as the construction of the particular room where the equipment is installed.
- ◆ Operation sound level may differ depending on operation and ambient conditions.

2) NC curves

(1) AVXCMH028E*

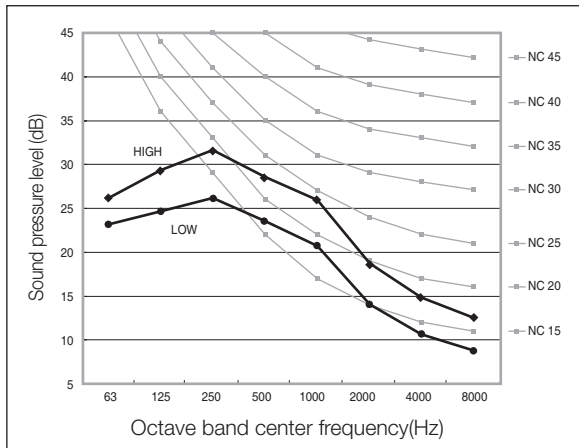

(2) AVXCMH036E*

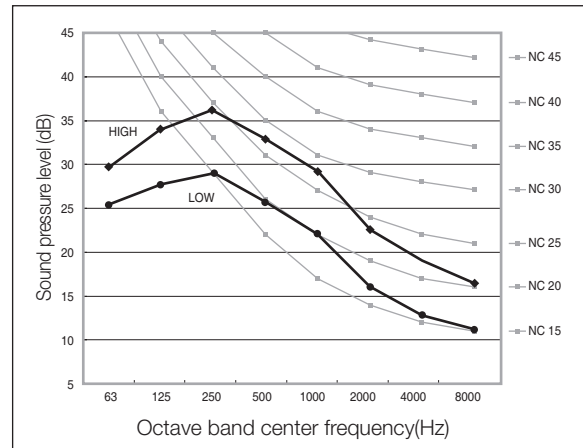

(3) AVXCMH056E*

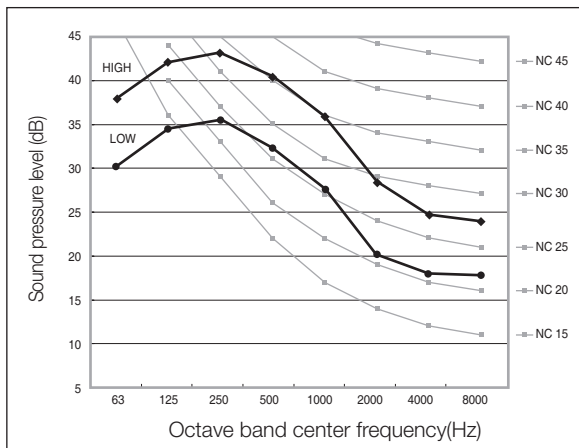

(4) AVXCMH060E*

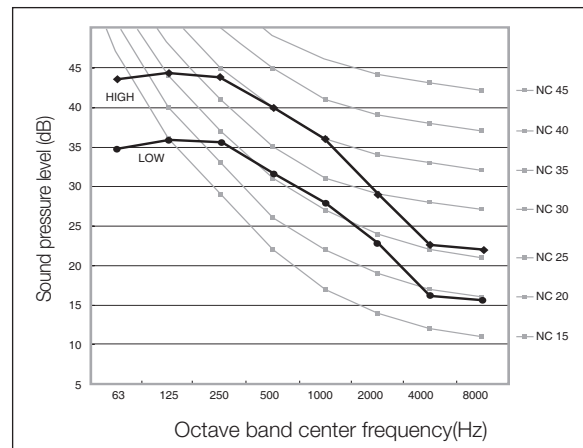

3-7. Temperature and air flow distribution

1) AVXCMH036E*

(1) Cooling air velocity distribution

◆ Discharge angle : 37°

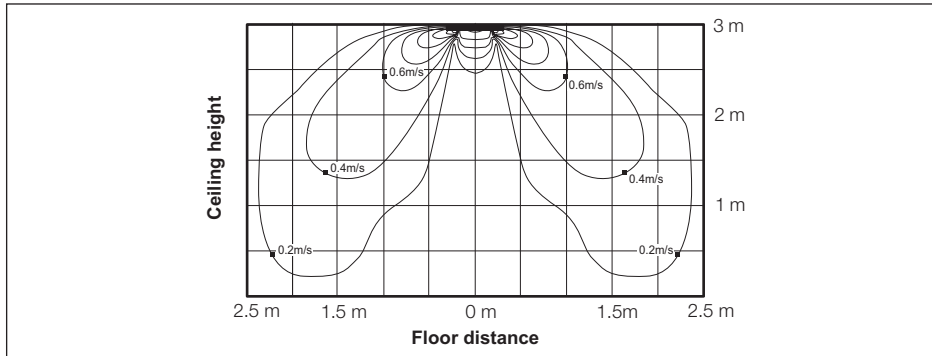

(2) Cooling temperature distribution

◆ Discharge angle : 37°

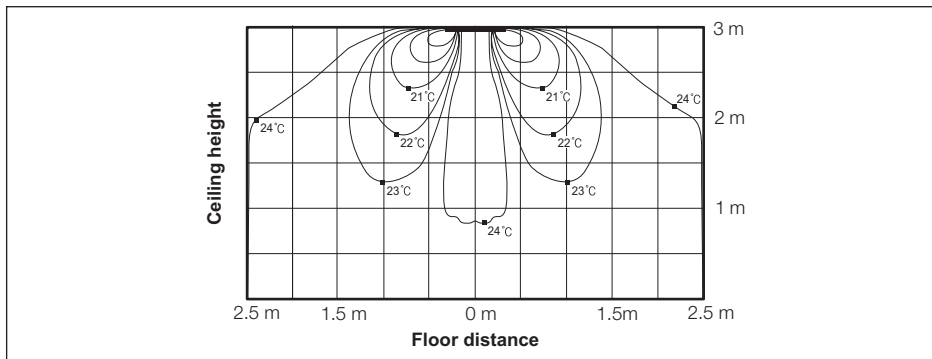

(3) Heating air velocity distribution

◆ Discharge angle : 49°

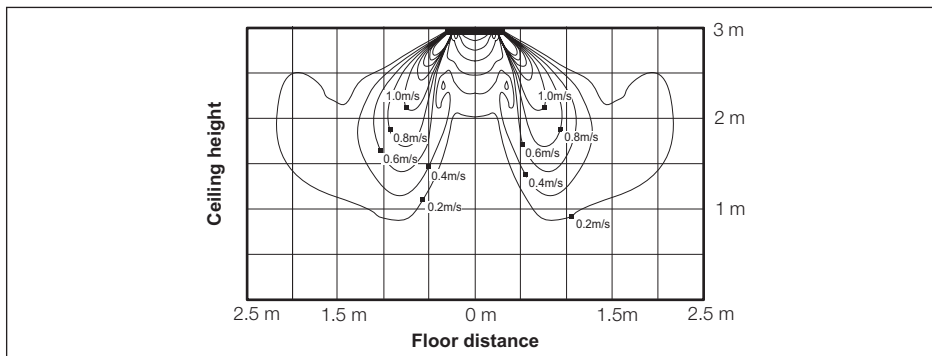

(4) Heating temperature distribution

◆ Discharge angle : 49°

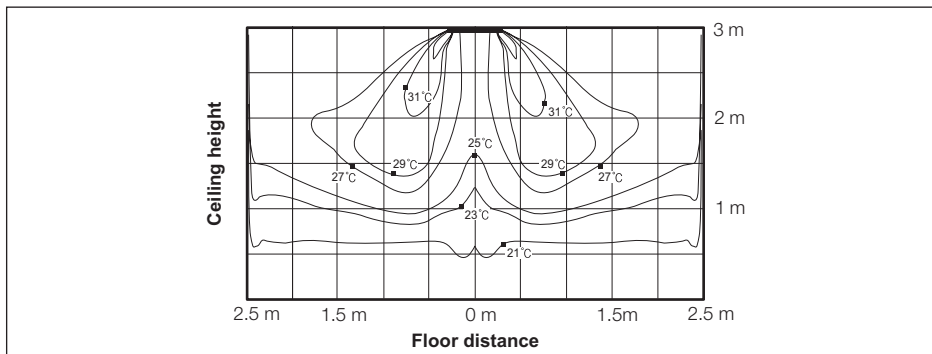

3 Mini 4 way cassette

3-7. Temperature and air flow distribution

2) AVXCMH060E*

(1) Cooling air velocity distribution

◆ Discharge angle : 37°

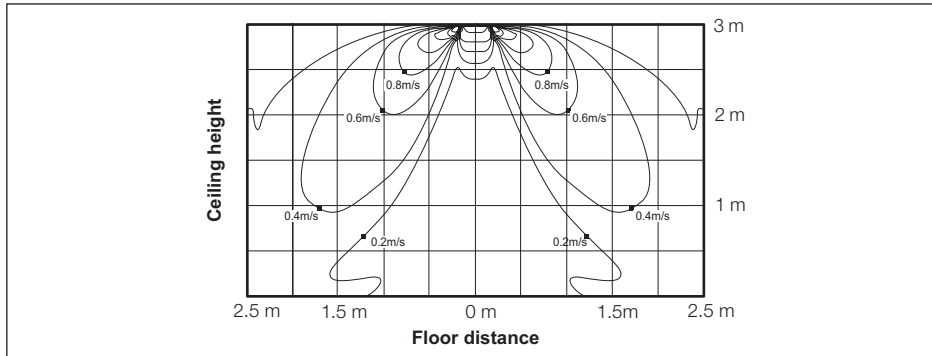

(2) Cooling temperature distribution

◆ Discharge angle : 37°

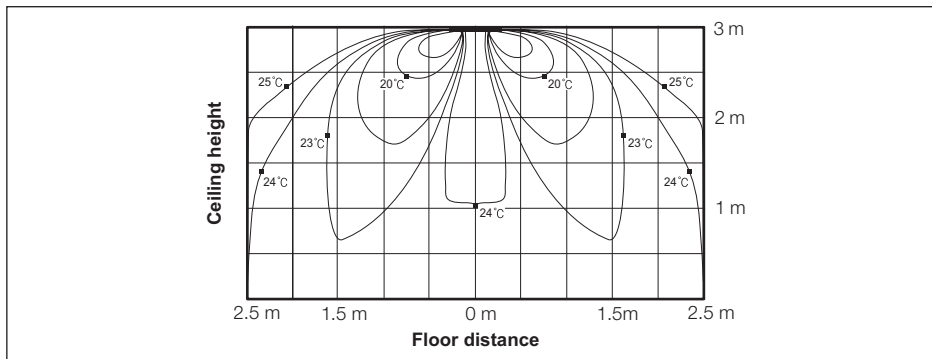

(3) Heating air velocity distribution

◆ Discharge angle : 49°

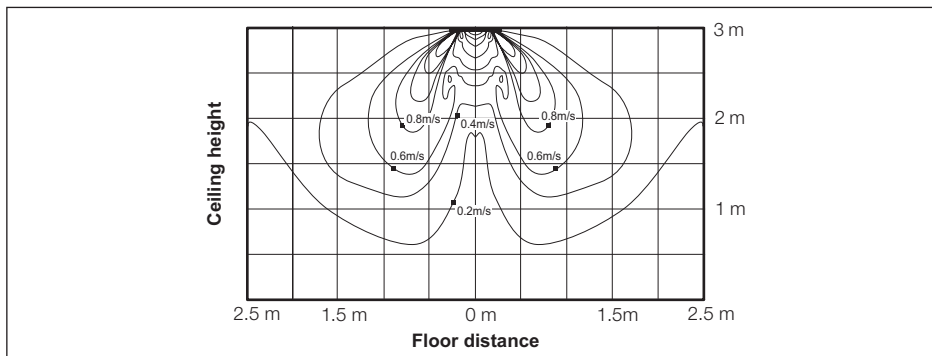

(4) Heating temperature distribution

◆ Discharge angle : 49°

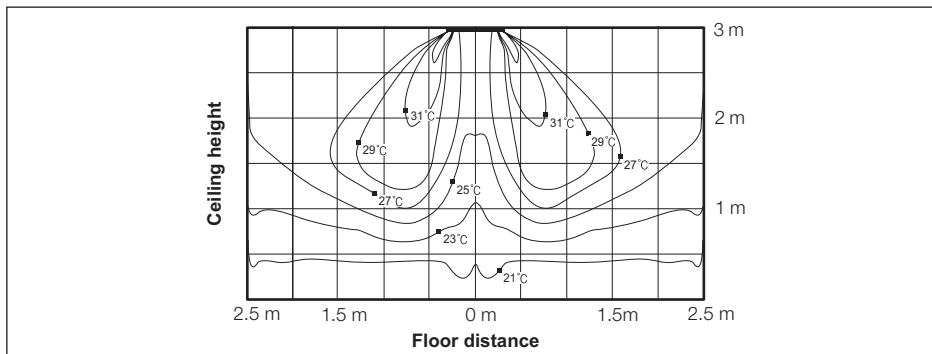



4 4 way cassette S (ND***4HXE*)

4-1. Features.....	46
4-2. Specifications.....	47
4-3. Capacity tables	48
4-4. Dimensional drawing	51
4-5. PCB connector lay-out.....	52
4-6. Electrical wiring diagram	53
4-7. Sound pressure level	54
4-8. Temperature and air flow distribution.....	55

Optional Accessories

Individual Controllers



MWR-WE10



MWR-WH00



MWR-SH00



MR-DH00

Panel



PC4NUSKA



PC4NUSKE



PC4NBSKA

4 4 way cassette S

4-1. Features

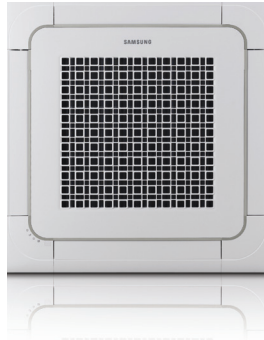

Stylish and Aesthetic Panel

The new 4Way Cassette S supports two panels with different pattern designs. You can select between the Waffle and Classic pattern, depending on your interior's look or personal preference.



Light yet Robust Design

Samsung's 4Way Cassette S indoor unit is now lighter in weight at 17kg. It is the lightest indoor unit in the industry, about 35% lighter than our competitors' products.

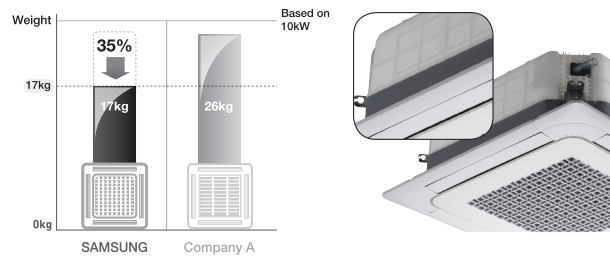

Individual Blade Control

By using the new remote controller, the opening angles of the 4 blades can be individually set at the same or different angles within a 32°~65° range for more efficient cooling.



No Overflowing Drain Water

The check valve on the drain pump prevents drained water from flowing backward into the drain pan. This minimizes the the drain pan's water level so that you will never have to worry about water stagnation or overflowing drain water that could drip into your interior.

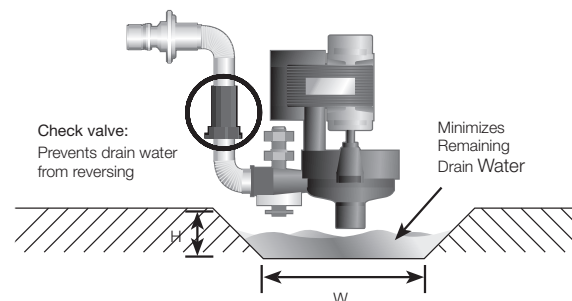

4-2. Specifications

1) Technical specifications

Model			ND0454HXEA	ND0564HXEA	ND0714HXEA	ND0904HXEA	ND1124HXEA	ND1284HXEA	ND1404HXEA	
Power Supply		Ø, #, V, Hz	1, 2, 220~240, 50	1, 2, 220~240, 50	1, 2, 220~240, 50	1, 2, 220~240, 50	1, 2, 220~240, 50	1, 2, 220~240, 50	1, 2, 220~240, 50	
Mode ^{*1)}		-	HP / HR	HP / HR	HP / HR	HP / HR	HP / HR	HP / HR	HP / HR	
Capacity (Nominal)	Cooling ^{*2)}	kW	4.5	5.6	7.1	9.0	11.2	12.8	14.0	
		Btu/h	15,400	19,100	24,200	30,700	38,200	43,700	47,800	
	Heating ^{*3)}	kW	5.0	6.3	8.0	10.0	12.5	13.8	16.0	
		Btu/h	17,100	21,500	27,300	34,100	42,700	47,100	54,600	
Power	Power Input (Nominal)	Cooling ^{*2)}	W	40	40	45	50	50	65	80
		Heating ^{*3)}	W	40	40	45	50	50	65	80
	Current Input (Nominal)	Cooling ^{*2)}	A	0.19	0.19	0.21	0.23	0.23	0.30	0.36
		Heating ^{*3)}	A	0.19	0.19	0.21	0.23	0.23	0.30	0.36
Fan	Motor	Type	-	Turbo Fan / BLDC	Turbo Fan / BLDC	Turbo Fan / BLDC	Turbo Fan / BLDC	Turbo Fan / BLDC	Turbo Fan / BLDC	
		Output	W							
		Number of unit	EA	1	1	1	1	1	1	1
	Air Flow Rate	H/M/L (UL)	CMM	14.5	15.0	17.0	19.5	26.0	28.0	30.0
			CFM	510 / 480 / 440	530 / 490 / 460	600 / 550 / 510	690 / 640 / 580	920 / 850 / 780	990 / 920 / 810	1060 / 990 / 920
	External Pressure	Min / Std / Max	mmAq	-	-	-	-	-	-	-
			Pa	-	-	-	-	-	-	-
WG			-	-	-	-	-	-	-	
Option Code		-	01407F-156097-232D2D-300008	01407F-1560A7-233838-300008	01407F-1460D8-234747-300008	01407F-156209-235A5A-300008	01407F-15621B-237070-300008	01407F-15622D-238089-300008	01407F-15624F-238C8C-300008	
Piping Connections	Liquid Pipe	Ø, mm	6.35	6.35	9.52	9.52	9.52	9.52	9.52	
		Ø, inch	1/4	1/4	3/8	3/8	3/8	3/8	3/8	
	Gas Pipe	Ø, mm	12.7	12.7	15.88	15.88	15.88	15.88	15.88	
		Ø, inch	1/2	1/2	5/8	5/8	5/8	5/8	5/8	
Drain Pipe	Ø, mm	ID25 Hose (OD 32, ID 25)	ID25 Hose (OD 32, ID 25)	ID25 Hose (OD 32, ID 25)	ID25 Hose (OD 32, ID 25)	ID25 Hose (OD 32, ID 25)	ID25 Hose (OD 32, ID 25)	ID25 Hose (OD 32, ID 25)		
Field Wiring	Power Source Wire	Below 20m / over 20m	mm ²	1.5 / 2.5	1.5 / 2.5	1.5 / 2.5	1.5 / 2.5	1.5 / 2.5	1.5 / 2.5	
	Transmission Cable		mm ²	0.75 / 1.5	0.75 / 1.5	0.75 / 1.5	0.75 / 1.5	0.75 / 1.5	0.75 / 1.5	
Refrigerant	Type	-	R410A	R410A	R410A	R410A	R410A	R410A	R410A	
	Control Method	-	EEV	EEV	EEV	EEV	EEV	EEV	EEV	
Sound	Sound Pressure	High / Low ^{*4)}	dBA	34/29	34/30	36/30	39/32	39/32	41/35	45/38
Dimensions	Net Weight		kg	15.1	15.1	15.1	15.1	17	18.7	18.7
	Shipping Weight		kg	19.1	19.1	19.1	19.1	20.5	22.8	22.8
	Net Dimensions (WxHxD)		mm	840 x 204 x 840	840 x 204 x 840	840 x 204 x 840	840 x 204 x 840	840 x 246 x 840	840 x 288 x 840	840 x 288 x 840
	Shipping Dimensions (WxHxD)		mm	910 x 226 x 910	910 x 226 x 910	910 x 226 x 910	910 x 226 x 910	910 x 268 x 910	910 x 310 x 910	910 x 310 x 910
Panel Size	Panel model		-	PC4NUSKA/PC4NUSKE	PC4NUSKA/PC4NUSKE	PC4NUSKA/PC4NUSKE	PC4NUSKA/PC4NUSKE	PC4NUSKA/PC4NUSKE	PC4NUSKA/PC4NUSKE	
	Panel Net Weight		kg	5.9	5.9	5.9	5.9	5.9	5.9	
	Shipping Weight		kg	8.4	8.4	8.4	8.4	8.4	8.4	
	Net Dimensions (WxHxD)		mm	950 x 45 x 950	950 x 45 x 950	950 x 45 x 950	950 x 45 x 950	950 x 45 x 950	950 x 45 x 950	
	Shipping Dimensions (WxHxD)		mm	1,005 x 100 x 1,005	1,005 x 100 x 1,005	1,005 x 100 x 1,005	1,005 x 100 x 1,005	1,005 x 100 x 1,005	1,005 x 100 x 1,005	
Additional Accessories	Drain pump	Drain pump	- / Model	Built-in	Built-in	Built-in	Built-in	Built-in	Built-in	
		Max. lifting Height / Displacement	mm/liter/h	750 / 24	750 / 24	750 / 24	750 / 24	750 / 24	750 / 24	
	Air Filter		-	Long life filter	Long life filter	Long life filter	Long life filter	Long life filter	Long life filter	

* Specifications may be subject to change without prior notice for product improvement.

*1) Mode

- HP : Heat Pump, HR : Heat Recovery

*2) Nominal cooling capacities are based on;

- Indoor temperature : 27°C DB, 19°C WB

- Outdoor temperature : 35°C DB, 24°C WB, Equivalent refrigerant piping : 7.5m, Level differences : 0m

*3) Nominal heating capacities are based on;

- Indoor temperature : 20°C DB, 15°C WB

- Outdoor temperature : 7°C DB, 6°C WB, Equivalent refrigerant piping : 7.5m, Level differences : 0m

*4) Sound pressure was acquired in a dead room. Thus actual noise level may be different depending on the installation conditions.

4 4 way cassette S

4-3. Capacity tables

1) Cooling

TC : Total Capacity(kW), SHC : Sensible Heat Capacity(kW)

Model	Outdoor temperature (°C, DB)	Indoor temperature (°C, WB)													
		20 (°C, DB) 14 (°C, WB)		23 (°C, DB) 16 (°C, WB)		26 (°C, DB) 18 (°C, WB)		27 (°C, DB) 19 (°C, WB)		28 (°C, DB) 20 (°C, WB)		30 (°C, DB) 22 (°C, WB)		32 (°C, DB) 24 (°C, WB)	
		TC	SHC	TC	SHC	TC	SHC	TC	SHC	TC	SHC	TC	SHC	TC	SHC
045	10	3.1	2.7	3.7	2.8	4.2	3.0	4.5	3.1	4.7	3.1	5.0	3.1	5.4	2.9
	12	3.1	2.7	3.7	2.8	4.2	3.0	4.5	3.1	4.7	3.1	5.0	3.1	5.4	2.9
	14	3.1	2.7	3.7	2.8	4.2	3.0	4.5	3.1	4.7	3.1	5.0	3.1	5.4	2.9
	16	3.1	2.7	3.7	2.8	4.2	3.0	4.5	3.1	4.7	3.1	5.0	3.1	5.3	2.8
	18	3.1	2.7	3.7	2.8	4.2	3.0	4.5	3.1	4.7	3.1	5.0	3.1	5.3	2.8
	20	3.1	2.7	3.7	2.8	4.2	3.0	4.5	3.1	4.7	3.1	5.0	3.1	5.3	2.8
	21	3.1	2.7	3.7	2.8	4.2	3.0	4.5	3.1	4.7	3.1	5.0	3.1	5.3	2.8
	23	3.1	2.7	3.7	2.8	4.2	3.0	4.5	3.1	4.7	3.1	5.0	3.1	5.3	2.8
	25	3.1	2.7	3.7	2.8	4.2	3.0	4.5	3.1	4.7	3.1	5.0	3.1	5.3	2.8
	27	3.1	2.7	3.7	2.8	4.2	3.0	4.5	3.1	4.7	3.1	5.0	3.1	5.3	2.8
	29	3.1	2.7	3.7	2.8	4.2	3.0	4.5	3.1	4.7	3.1	5.0	3.1	5.3	2.8
	31	3.1	2.7	3.7	2.8	4.2	3.0	4.5	3.1	4.7	3.1	5.0	3.1	5.3	2.8
	33	3.1	2.7	3.7	2.8	4.2	3.0	4.5	3.1	4.7	3.1	5.0	3.1	5.3	2.8
	35	3.1	2.7	3.7	2.8	4.2	3.0	4.5	3.1	4.7	3.1	5.0	3.1	5.3	2.8
	37	3.1	2.7	3.7	2.8	4.2	3.0	4.5	3.1	4.6	3.0	4.9	3.0	5.2	2.7
39	3.1	2.7	3.7	2.8	4.2	3.0	4.5	3.1	4.6	3.0	4.9	3.0	5.1	2.6	
42	3.1	2.7	3.7	2.8	4.2	3.0	4.5	3.0	4.5	2.9	4.6	2.7	4.8	2.5	
44	3.1	2.7	3.7	2.8	4.0	2.9	4.3	2.9	4.3	2.8	4.4	2.6	4.5	2.4	
056	10	3.9	3.2	4.6	3.5	5.3	3.9	5.6	3.9	5.8	3.9	6.3	3.9	6.7	3.7
	12	3.9	3.2	4.6	3.5	5.3	3.9	5.6	3.9	5.8	3.9	6.3	3.9	6.7	3.7
	14	3.9	3.2	4.6	3.5	5.3	3.9	5.6	3.9	5.8	3.9	6.2	3.8	6.7	3.7
	16	3.9	3.2	4.6	3.5	5.3	3.9	5.6	3.9	5.8	3.9	6.2	3.8	6.6	3.6
	18	3.9	3.2	4.6	3.5	5.3	3.9	5.6	3.9	5.8	3.9	6.2	3.8	6.6	3.6
	20	3.9	3.2	4.6	3.5	5.3	3.9	5.6	3.9	5.8	3.9	6.2	3.8	6.6	3.6
	21	3.9	3.2	4.6	3.5	5.3	3.9	5.6	3.9	5.8	3.9	6.2	3.8	6.6	3.6
	23	3.9	3.2	4.6	3.5	5.3	3.9	5.6	3.9	5.8	3.9	6.2	3.8	6.6	3.6
	25	3.9	3.2	4.6	3.5	5.3	3.9	5.6	3.9	5.8	3.9	6.2	3.8	6.6	3.6
	27	3.9	3.2	4.6	3.5	5.3	3.9	5.6	3.9	5.8	3.9	6.2	3.8	6.6	3.6
	29	3.9	3.2	4.6	3.5	5.3	3.9	5.6	3.9	5.8	3.9	6.2	3.8	6.6	3.6
	31	3.9	3.2	4.6	3.5	5.3	3.9	5.6	3.9	5.8	3.9	6.2	3.8	6.6	3.6
	33	3.9	3.2	4.6	3.5	5.3	3.9	5.6	3.9	5.8	3.9	6.2	3.8	6.6	3.6
	35	3.9	3.2	4.6	3.5	5.3	3.9	5.6	3.9	5.8	3.9	6.2	3.8	6.6	3.6
	37	3.9	3.2	4.6	3.5	5.3	3.9	5.6	3.9	5.8	3.9	6.2	3.8	6.6	3.5
39	3.9	3.2	4.6	3.5	5.3	3.9	5.6	3.9	5.8	3.9	6.2	3.8	6.6	3.4	
42	3.9	3.2	4.6	3.5	5.3	3.9	5.4	3.8	5.6	3.8	5.8	3.6	6.0	3.2	
44	3.9	3.2	4.6	3.5	5.0	3.8	5.3	3.7	5.4	3.7	5.5	3.5	5.6	3.0	
071	10	4.9	4.0	5.8	4.5	6.7	4.8	7.1	5.0	7.4	5.0	8.0	5.1	8.5	4.8
	12	4.9	4.0	5.8	4.5	6.7	4.8	7.1	5.0	7.4	5.0	7.9	5.0	8.5	4.8
	14	4.9	4.0	5.8	4.5	6.7	4.8	7.1	5.0	7.4	5.0	7.9	5.0	8.4	4.8
	16	4.9	4.0	5.8	4.5	6.7	4.8	7.1	5.0	7.4	5.0	7.9	5.0	8.4	4.8
	18	4.9	4.0	5.8	4.5	6.7	4.8	7.1	5.0	7.4	5.0	7.9	5.0	8.4	4.8
	20	4.9	4.0	5.8	4.5	6.7	4.8	7.1	5.0	7.4	5.0	7.9	5.0	8.4	4.8
	21	4.9	4.0	5.8	4.5	6.7	4.8	7.1	5.0	7.4	5.0	7.9	5.0	8.4	4.8
	23	4.9	4.0	5.8	4.5	6.7	4.8	7.1	5.0	7.4	5.0	7.9	5.0	8.4	4.8
	25	4.9	4.0	5.8	4.5	6.7	4.8	7.1	5.0	7.4	5.0	7.9	5.0	8.4	4.8
	27	4.9	4.0	5.8	4.5	6.7	4.8	7.1	5.0	7.4	5.0	7.9	5.0	8.4	4.8
	29	4.9	4.0	5.8	4.5	6.7	4.8	7.1	5.0	7.4	5.0	7.9	5.0	8.4	4.8
	31	4.9	4.0	5.8	4.5	6.7	4.8	7.1	5.0	7.4	5.0	7.9	5.0	8.4	4.8
	33	4.9	4.0	5.8	4.5	6.7	4.8	7.1	5.0	7.4	5.0	7.9	5.0	8.4	4.8
	35	4.9	4.0	5.8	4.5	6.7	4.8	7.1	5.0	7.4	5.0	7.9	5.0	8.4	4.8
	37	4.9	4.0	5.8	4.5	6.7	4.8	7.1	5.0	7.3	4.9	7.8	4.9	8.2	4.7
39	4.9	4.0	5.8	4.5	6.7	4.8	7.1	5.0	7.3	4.9	7.7	4.8	8.1	4.6	
42	4.9	4.0	5.8	4.5	6.7	4.8	6.9	4.8	7.0	4.7	7.3	4.6	7.6	4.4	
44	4.9	4.0	5.8	4.5	6.3	4.6	6.7	4.5	6.8	4.6	7.0	4.5	7.1	4.2	
090	10	6.2	5.2	7.3	5.7	8.4	6.3	9.0	6.3	9.4	6.3	10.1	6.3	10.8	6.3
	12	6.2	5.2	7.3	5.7	8.4	6.3	9.0	6.3	9.4	6.3	10.1	6.3	10.8	6.3
	14	6.2	5.2	7.3	5.7	8.4	6.3	9.0	6.3	9.3	6.3	10.0	6.2	10.7	6.2
	16	6.2	5.2	7.3	5.7	8.4	6.3	9.0	6.3	9.3	6.3	10.0	6.2	10.7	6.2
	18	6.2	5.2	7.3	5.7	8.4	6.3	9.0	6.3	9.3	6.3	10.0	6.2	10.6	6.1
	20	6.2	5.2	7.3	5.7	8.4	6.3	9.0	6.3	9.3	6.3	10.0	6.2	10.6	6.1
	21	6.2	5.2	7.3	5.7	8.4	6.3	9.0	6.3	9.3	6.3	10.0	6.2	10.6	6.1
	23	6.2	5.2	7.3	5.7	8.4	6.3	9.0	6.3	9.3	6.3	10.0	6.2	10.6	6.1
	25	6.2	5.2	7.3	5.7	8.4	6.3	9.0	6.3	9.3	6.3	10.0	6.2	10.6	6.1
	27	6.2	5.2	7.3	5.7	8.4	6.3	9.0	6.3	9.3	6.3	10.0	6.2	10.6	6.1
	29	6.2	5.2	7.3	5.7	8.4	6.3	9.0	6.3	9.3	6.3	10.0	6.2	10.6	6.1
	31	6.2	5.2	7.3	5.7	8.4	6.3	9.0	6.3	9.3	6.3	10.0	6.2	10.6	6.1
	33	6.2	5.2	7.3	5.7	8.4	6.3	9.0	6.3	9.3	6.3	10.0	6.2	10.6	6.1
	35	6.2	5.2	7.3	5.7	8.4	6.3	9.0	6.3	9.3	6.3	10.0	6.2	10.6	6.1
	37	6.2	5.2	7.3	5.7	8.4	6.3	9.0	6.3	9.3	6.3	9.9	6.1	10.4	6.0
39	6.2	5.2	7.3	5.7	8.4	6.3	9.0	6.4	9.2	6.2	9.7	6.0	10.2	5.9	
42	6.2	5.2	7.3	5.7	8.4	6.3	8.7	6.2	8.9	6.2	9.3	5.8	9.6	5.8	
44	6.2	5.2	7.3	5.7	8.0	6.1	8.6	6.1	8.6	6.1	8.8	5.6	9.0	5.5	
112	10	7.7	6.4	9.1	7.1	10.5	7.8	11.2	7.9	11.6	7.9	12.5	7.9	13.4	7.9
	12	7.7	6.4	9.1	7.1	10.5	7.8	11.2	7.9	11.6	7.9	12.5	7.9	13.4	7.9
	14	7.7	6.4	9.1	7.1	10.5	7.8	11.2	7.9	11.6	7.9	12.5	7.9	13.3	7.8
	16	7.7	6.4	9.1	7.1	10.5	7.8	11.2	7.9	11.6	7.9	12.5	7.9	13.3	7.8
	18	7.7	6.4	9.1	7.1	10.5	7.8	11.2	7.9	11.6	7.9	12.4	7.9	13.2	7.7
	20	7.7	6.4	9.1	7.1	10.5	7.8	11.2	7.9	11.6	7.9	12.4	7.9	13.2	7.7
	21	7.7	6.4	9.1	7.1	10.5	7.8	11.2	7.9	11.6	7.9	12.4	7.9	13.2	7.7
	23	7.7	6.4	9.1	7.1	10.5	7.8	11.2	7.9	11.6	7.9	12.4	7.9	13.2	7.7
	25	7.7	6.4	9.1	7.1	10.5	7.8	11.2	7.9	11.6	7.9	12.4	7.9	13.2	7.7
	27	7.7	6.4	9.1	7.1	10.5	7.8	11.2	7.9	11.6	7.9	12.4	7.9	13.2	7.7
	29	7.7	6.4	9.1	7.1	10.5	7.8	11.2	7.9	11.6	7.9	12.4	7.9	13.2	7.7
	31	7.7	6.4	9.1	7.1	10.5	7.8	11.2	7.9	11.6	7.9	12.4	7.9	13.2	7.7
	33	7.7	6.3	9.1	7.0	10.5	7.8	11.2	7.9	11.6	7.9	12.4	7.9	13.2	7.7
	35	7.7	6.3	9.1	7.0	10.5	7.8	11.2	7.9	11.6	7.9	12.4	7.9	13.2	7.7
	37	7.7	6.3	9.1	7.0	10.5	7.8	11.2	7.9	11.6	7.9	12.3	7.8	13.0	7.6
39	7.7	6.3	9.1	7.0	10.5	7.8	11.2	8.0	11.5	7.8	12.1	7.7	12.7	7.5	
42	7.7	6.3	9.1	7.0	10.5	7.8	10.9	7.7	11.1	7.6	11.6	7.5	12.0	7.4	
44	7.7	6.3	9.1	7.0	10.0	7.4	10.6	7.6	10.8	7.5	11.0	7.2	11.2	7.0	

TC : Total Capacity(kW), SHC : Sensible Heat Capacity(kW)

Model	Outdoor temperature (°C, DB)	Indoor temperature (°C, WB)													
		20 (°C, DB)		23 (°C, DB)		26 (°C, DB)		27 (°C, DB)		28 (°C, DB)		30 (°C, DB)		32 (°C, DB)	
		14 (°C, WB)		16 (°C, WB)		18 (°C, WB)		19 (°C, WB)		20 (°C, WB)		22 (°C, WB)		24 (°C, WB)	
		TC	SHC	TC	SHC	TC	SHC	TC	SHC	TC	SHC	TC	SHC	TC	SHC
128	10	8.8	7.3	10.4	8.1	12.0	9.0	12.8	9.1	13.3	9.1	14.3	9.1	15.4	9.1
	12	8.8	7.3	10.4	8.1	12.0	9.0	12.8	9.1	13.3	9.1	14.3	9.1	15.3	9.0
	14	8.8	7.3	10.4	8.1	12.0	9.0	12.8	9.1	13.3	9.1	14.3	9.1	15.3	9.0
	16	8.8	7.3	10.4	8.1	12.0	9.0	12.8	9.1	13.3	9.1	14.2	9.0	15.2	8.9
	18	8.8	7.3	10.4	8.1	12.0	9.0	12.8	9.1	13.3	9.1	14.2	9.0	15.1	8.8
	20	8.8	7.3	10.4	8.1	12.0	9.0	12.8	9.1	13.3	9.1	14.2	9.0	15.1	8.8
	21	8.8	7.3	10.4	8.1	12.0	9.0	12.8	9.1	13.3	9.1	14.2	9.0	15.1	8.8
	23	8.8	7.3	10.4	8.1	12.0	9.0	12.8	9.1	13.3	9.1	14.2	9.0	15.1	8.8
	25	8.8	7.3	10.4	8.1	12.0	9.0	12.8	9.1	13.3	9.1	14.2	9.0	15.1	8.8
	27	8.8	7.3	10.4	8.1	12.0	9.0	12.8	9.1	13.3	9.1	14.2	9.0	15.1	8.8
	29	8.8	7.3	10.4	8.1	12.0	9.0	12.8	9.1	13.3	9.1	14.2	9.0	15.1	8.8
	31	8.8	7.3	10.4	8.1	12.0	9.0	12.8	9.1	13.3	9.1	14.2	9.0	15.1	8.8
	33	8.8	7.3	10.4	8.1	12.0	9.0	12.8	9.1	13.3	9.1	14.2	9.0	15.1	8.8
	35	8.8	7.3	10.4	8.1	12.0	9.0	12.8	9.1	13.3	9.1	14.2	9.0	15.1	8.8
	37	8.8	7.3	10.4	8.1	12.0	9.0	12.8	9.1	13.2	9.0	14.0	8.9	14.9	8.7
	39	8.8	7.3	10.4	8.1	12.0	9.0	12.8	9.2	13.1	8.9	13.8	8.8	14.5	8.6
42	8.8	7.3	10.4	8.1	12.0	9.0	12.4	8.9	12.7	8.8	13.2	8.6	13.7	8.4	
44	8.8	7.3	10.4	8.1	11.4	8.7	12.2	8.6	12.3	8.6	12.5	8.3	12.8	8.0	
140	10	9.7	7.7	11.4	8.5	13.1	9.4	14.0	9.6	14.6	9.6	15.7	9.5	16.8	9.7
	12	9.7	7.7	11.4	8.5	13.1	9.4	14.0	9.6	14.5	9.6	15.6	9.6	16.7	9.6
	14	9.7	7.7	11.4	8.5	13.1	9.4	14.0	9.6	14.5	9.6	15.6	9.6	16.7	9.6
	16	9.7	7.7	11.4	8.5	13.1	9.4	14.0	9.6	14.5	9.6	15.6	9.6	16.6	9.5
	18	9.7	7.7	11.4	8.5	13.1	9.4	14.0	9.6	14.5	9.6	15.5	9.5	16.6	9.5
	20	9.7	7.7	11.4	8.5	13.1	9.4	14.0	9.6	14.5	9.6	15.5	9.5	16.5	9.4
	21	9.7	7.7	11.4	8.5	13.1	9.4	14.0	9.6	14.5	9.6	15.5	9.5	16.5	9.4
	23	9.7	7.7	11.4	8.5	13.1	9.4	14.0	9.6	14.5	9.6	15.5	9.5	16.5	9.4
	25	9.7	7.7	11.4	8.5	13.1	9.4	14.0	9.6	14.5	9.6	15.5	9.5	16.5	9.4
	27	9.7	7.7	11.4	8.5	13.1	9.4	14.0	9.6	14.5	9.6	15.5	9.5	16.5	9.4
	29	9.7	7.7	11.4	8.5	13.1	9.4	14.0	9.6	14.5	9.6	15.5	9.5	16.5	9.4
	31	9.7	7.7	11.4	8.5	13.1	9.4	14.0	9.6	14.5	9.6	15.5	9.5	16.5	9.4
	33	9.7	7.7	11.4	8.5	13.1	9.4	14.0	9.6	14.5	9.6	15.5	9.5	16.5	9.4
	35	9.7	7.7	11.4	8.5	13.1	9.4	14.0	9.6	14.5	9.6	15.5	9.5	16.5	9.4
	37	9.7	7.7	11.4	8.5	13.1	9.4	14.0	9.6	14.5	9.6	15.4	9.4	16.3	9.2
	39	9.7	7.7	11.4	8.5	13.1	9.4	14.0	9.6	14.4	9.4	15.1	9.3	15.9	9.0
42	9.7	7.7	11.4	8.5	13.1	9.4	13.6	9.3	13.9	9.2	14.4	8.9	15.0	8.5	
44	9.7	7.7	11.4	8.5	12.5	9.1	13.3	9.2	13.4	8.8	13.7	8.4	14.0	8.1	

Indoor units

2) Heating

TC : Total Capacity(kW)

Model	Outdoor temperature (°C)		Indoor temperature (°C, DB)									
			16.0		18.0		20.0		22.0		24.0	
			TC	TC	TC	TC	TC	TC	TC	TC		
	DB	WB	kW	kW	kW	kW	kW	kW	kW	kW		
045	-20	-21	3.1	3.1	2.9	2.9	2.9					
	-17	-18	3.2	3.2	3.1	3.0	3.0					
	-15	-16	3.3	3.3	3.2	3.1	3.0					
	-12	-13	3.5	3.4	3.4	3.3	3.2					
	-10	-11	3.7	3.6	3.6	3.5	3.5					
	-7	-8	3.9	3.8	3.8	3.7	3.6					
	-5	-6	4.1	4.0	4.0	3.9	3.7					
	-3	-4	4.3	4.2	4.2	4.0	3.9					
	0	-1	4.5	4.4	4.4	4.2	4.0					
	3	2.2	4.7	4.7	4.6	4.4	4.2					
	5	4.1	4.9	4.9	4.8	4.5	4.2					
	7	6	5.1	5.1	5.0	4.6	4.2					
	9	7.9	5.3	5.2	5.0	4.6	4.2					
	11	9.8	5.5	5.2	5.0	4.6	4.2					
	13	12	5.6	5.3	5.0	4.6	4.2					
15	14	5.8	5.4	5.0	4.6	4.2						
056	-20	-21	3.9	3.8	3.8	3.7	3.7					
	-17	-18	4.0	4.0	3.9	3.8	3.8					
	-15	-16	4.2	4.1	4.0	3.9	3.8					
	-12	-13	4.4	4.3	4.2	4.2	4.1					
	-10	-11	4.6	4.6	4.5	4.4	4.4					
	-7	-8	4.9	4.8	4.8	4.7	4.5					
	-5	-6	5.2	5.1	5.0	4.9	4.7					
	-3	-4	5.4	5.3	5.3	5.1	4.9					
	0	-1	5.7	5.6	5.5	5.3	5.0					
	3	2.2	5.9	5.9	5.8	5.6	5.3					
	5	4.1	6.2	6.1	6.0	5.7	5.3					
	7	6	6.5	6.4	6.3	5.8	5.3					
	9	7.9	6.7	6.5	6.3	5.8	5.3					
	11	9.8	6.9	6.6	6.3	5.8	5.3					
	13	12	7.1	6.7	6.3	5.8	5.3					
15	14	7.3	6.8	6.3	5.8	5.3						

4 4 way cassette S

4-3. Capacity tables

2) Heating

TC : Total Capacity(kW)

Model	Outdoor temperature (°C)		Indoor temperature (°C, DB)				
			16.0	18.0	20.0	22.0	24.0
	DB	WB	TC	TC	TC	TC	TC
071	-20	-21	4.9	4.9	4.8	4.7	4.7
	-17	-18	5.1	5.0	4.9	4.8	4.8
	-15	-16	5.3	5.2	5.1	4.9	4.8
	-12	-13	5.6	5.5	5.4	5.3	5.2
	-10	-11	5.9	5.8	5.7	5.6	5.6
	-7	-8	6.2	6.1	6.0	5.9	5.8
	-5	-6	6.5	6.5	6.4	6.2	6.0
	-3	-4	6.9	6.8	6.7	6.4	6.2
	0	-1	7.2	7.1	7.0	6.7	6.4
	3	2.2	7.6	7.5	7.3	7.1	6.8
	5	4.1	7.9	7.8	7.7	7.2	6.8
	7	6	8.2	8.1	8.0	7.4	6.8
	9	7.9	8.5	8.2	8.0	7.4	6.8
	11	9.8	8.7	8.4	8.0	7.4	6.8
	13	12	9.0	8.5	8.0	7.4	6.8
15	14	9.2	8.6	8.0	7.4	6.8	
090	-20	-21	6.0	6.0	5.9	5.8	5.8
	-17	-18	6.3	6.3	6.1	6.0	5.9
	-15	-16	6.7	6.5	6.3	6.1	6.0
	-12	-13	7.0	6.9	6.7	6.6	6.5
	-10	-11	7.3	7.2	7.1	7.0	7.0
	-7	-8	7.8	7.7	7.6	7.4	7.2
	-5	-6	8.2	8.1	8.0	7.7	7.5
	-3	-4	8.6	8.5	8.4	8.1	7.7
	0	-1	9.0	8.9	8.8	8.4	8.0
	3	2.2	9.4	9.3	9.2	8.8	8.4
	5	4.1	9.9	9.7	9.6	9.0	8.4
	7	6	10.3	10.1	10.0	9.2	8.4
	9	7.9	10.6	10.3	10.0	9.2	8.4
	11	9.8	10.9	10.5	10.0	9.2	8.4
	13	12	11.2	10.6	10.0	9.2	8.4
15	14	11.6	10.8	10.0	9.2	8.4	
112	-20	-21	7.4	7.4	7.3	7.3	7.3
	-17	-18	8.0	7.8	7.6	7.5	7.4
	-15	-16	8.4	8.1	7.9	7.7	7.5
	-12	-13	8.8	8.6	8.4	8.2	8.1
	-10	-11	9.2	9.0	8.9	8.8	8.7
	-7	-8	9.7	9.6	9.4	9.2	9.0
	-5	-6	10.2	10.1	9.9	9.6	9.3
	-3	-4	10.7	10.6	10.5	10.1	9.7
	0	-1	11.3	11.1	11.1	10.5	10.0
	3	2.2	11.8	11.6	11.5	11.0	10.6
	5	4.1	12.3	12.2	12.0	11.3	10.6
	7	6	12.9	12.7	12.5	11.5	10.6
	9	7.9	13.3	12.9	12.5	11.5	10.6
	11	9.8	13.7	13.1	12.5	11.5	10.6
	13	12	14.0	13.3	12.5	11.5	10.6
15	14	14.4	13.5	12.5	11.5	10.6	
128	-20	-21	8.1	8.1	8.0	8.0	8.0
	-17	-18	8.7	8.5	8.4	8.3	8.1
	-15	-16	9.2	9.0	8.7	8.5	8.2
	-12	-13	9.7	9.5	9.3	9.1	8.9
	-10	-11	10.1	10.0	9.9	9.7	9.6
	-7	-8	10.7	10.6	10.4	10.2	10.0
	-5	-6	11.3	11.1	11.0	10.7	10.3
	-3	-4	11.9	11.7	11.5	11.1	10.7
	0	-1	12.4	12.3	12.1	11.6	11.0
	3	2.2	13.0	12.9	12.7	12.2	11.7
	5	4.1	13.6	13.4	13.2	12.4	11.7
	7	6	14.2	14.0	13.8	12.7	11.7
	9	7.9	14.6	14.2	13.8	12.7	11.7
	11	9.8	15.1	14.4	13.8	12.7	11.7
	13	12	15.5	14.7	13.8	12.7	11.7
15	14	15.9	14.9	13.8	12.7	11.7	
140	-20	-21	9.5	9.5	9.4	9.4	9.3
	-17	-18	10.1	9.9	9.6	9.6	9.4
	-15	-16	10.7	10.4	10.1	9.8	9.5
	-12	-13	11.2	11.0	10.8	10.6	10.3
	-10	-11	11.7	11.6	11.4	11.3	11.1
	-7	-8	12.4	12.2	12.1	11.8	11.5
	-5	-6	13.1	12.9	12.7	12.3	12.0
	-3	-4	13.8	13.6	13.4	12.9	12.4
	0	-1	14.4	14.2	14.0	13.4	12.8
	3	2.2	15.1	14.9	14.7	14.1	13.5
	5	4.1	15.8	15.6	15.3	14.4	13.5
	7	6	16.5	16.2	16.0	14.8	13.5
	9	7.9	17.0	16.5	16.0	14.8	13.5
	11	9.8	17.5	16.7	16.0	14.8	13.5
	13	12	18.0	17.0	16.0	14.8	13.5
15	14	18.5	17.2	16.0	14.8	13.5	

4-4 . Dimensional drawing

Unit:mm

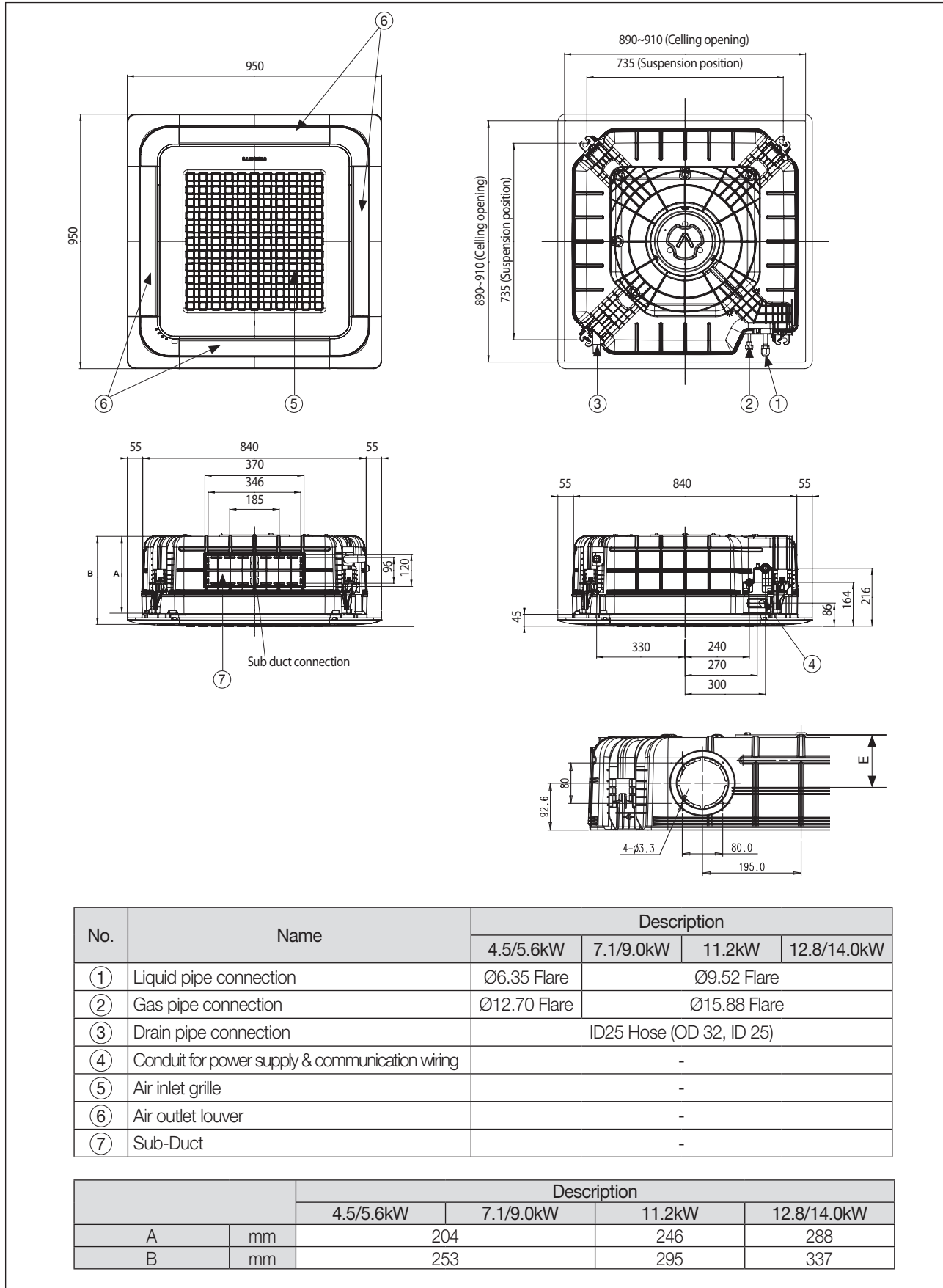

Indoor units

4 way cassette S

4-5. PCB connector lay-out

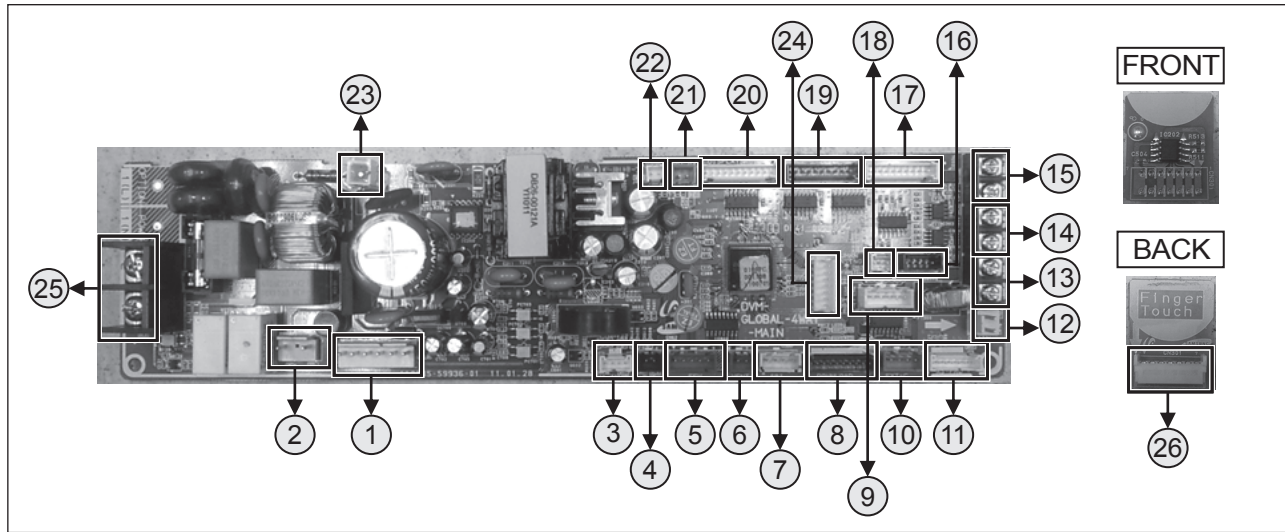

No.	USE	No.	USE
①	BLDC MOTOR(YW396-06V WHT)	⑭	DC 12V
②	AC DRAIN(YW396-03AV YEL)	⑮	COM2 COMMUNICATION
③	EVA IN/OUT Sensor(SMW200-04P WHT)	⑯	AUTO GRILL(SMW250-02P BLK)
④	FLOATING Sensor(SMW250-02P BLK)	⑰	LOUVER 1/2(SMW200-10P WHT)
⑤	EEV(SMW250-05P BLU)	⑱	HUMAN SENSING(SMW200-03P YEL)
⑥	VENT(SMW250-02P BLU)	⑲	LOUVER 3/4(SMW200-10P BLU)
⑦	SPI(SMW250-04P YEL)	⑳	DISPLAY(SMW200-11P WHT)
⑧	MICOM DOWNLOAD(PC)(SMW200-10P BLK)	㉑	EXTERNAL SIGNAL(SMW250-02P RED)
⑨	ROBOT CLEANER(SMW250-05P WHT)	㉒	ROOM SENSOR(SMW200-02P WHT)
⑩	EXTERNAL Check OUT(SMW250-04P RED)	㉓	SET GROUND(YDW236-01 WHT)
⑪	MICOM DOWNLOAD(AS-PRO) (SMW200-04P WHT)	㉔	EEPROM PBA CONNECT(B7P-MQ WHT)
⑫	DC DRAIN(YW396-02V YEL)	㉕	MAIN POWER IN
⑬	COM1 COMMUNICATION	㉖	MAIN PBA CONNECT(07MQ-ST WHT)

4-6. Electrical wiring diagram

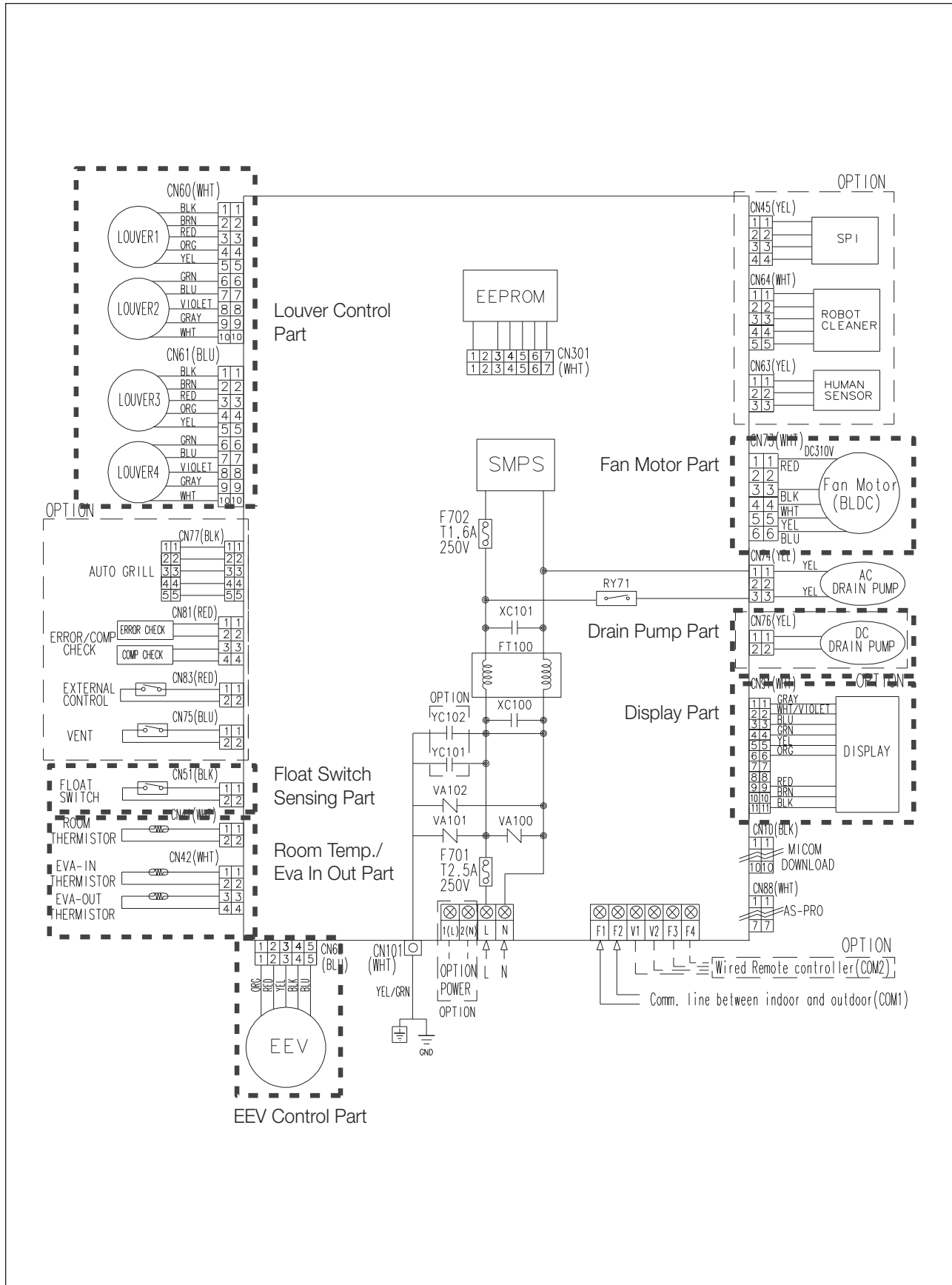

Indoor units

4 4 way cassette S

4-7. Sound pressure level

1) Operation sound level

Unit : dB(A)



Model	High	Low
ND0454HXE*	34	29
ND0564HXE*	34	30
ND0714HXE*	36	30
ND0904HXE*	39	32
ND1124HXE*	39	32
ND1284HXE*	41	35
ND1404HXE*	45	38

✓ Note

- ◆ These operation values were obtained in a dead room. Sound pressure level will vary depending on a range of factors such as the construction of the particular room where the equipment is installed.
- ◆ Operation sound level may differ depending on operation and ambient conditions.

2) NC curves

(1) ND0454HXE*

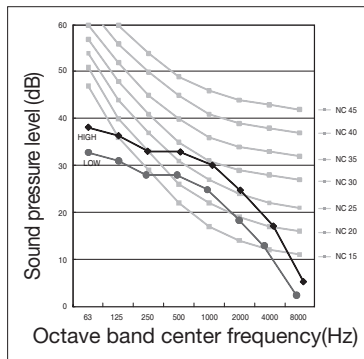

(2) ND0564HXE*

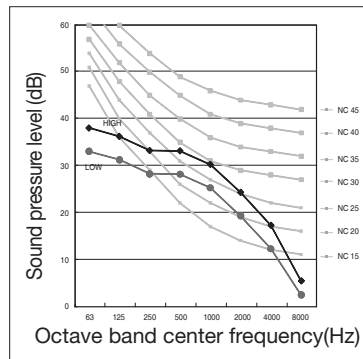

(3) ND0714HXE*

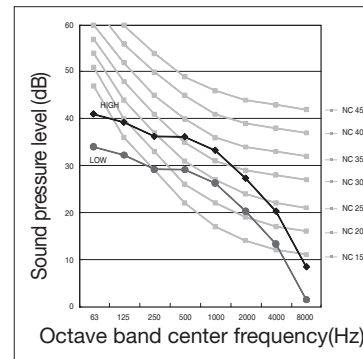

(4) ND0904HXE*

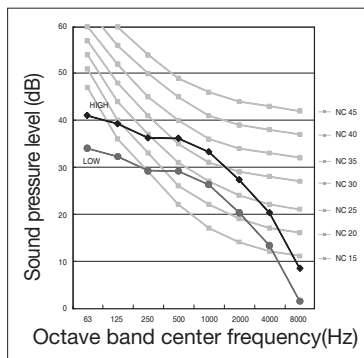

(5) ND1124HXE*

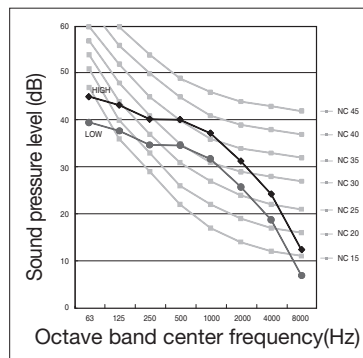

(6) ND1284HXE*

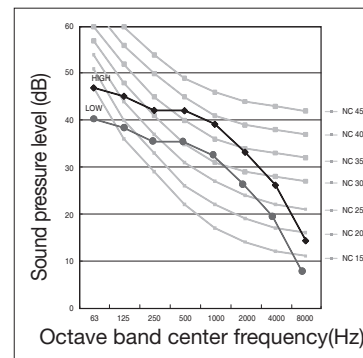

(7) ND1404HXE*

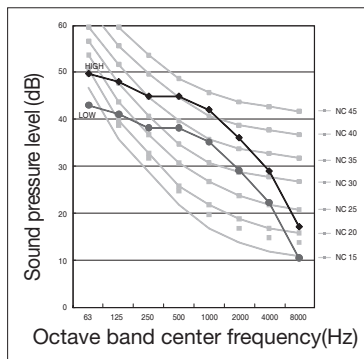

4-8. Temperature and air flow distribution

1) ND0904HXEA

(1) Cooling air velocity distribution

◆ Discharge angle : 45°

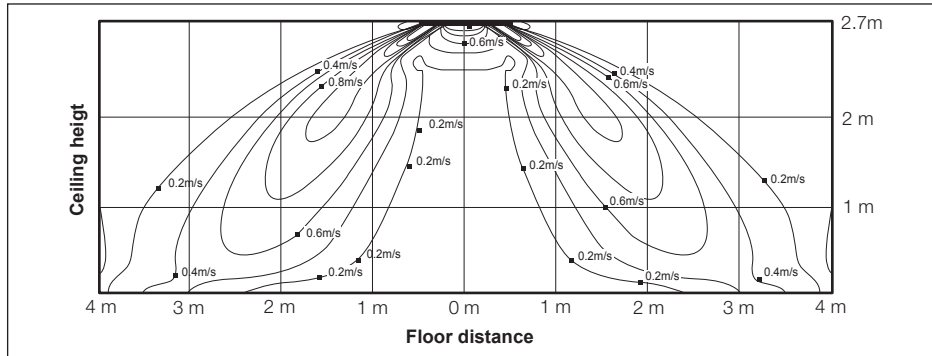

(2) Cooling temperature distribution

◆ Discharge angle : 45°

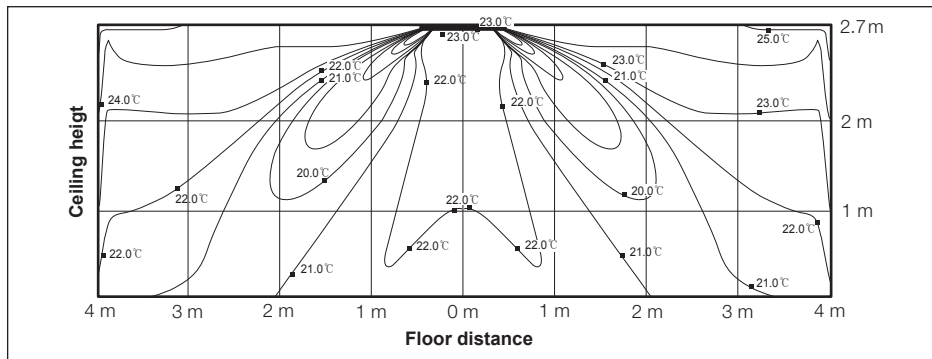

(3) Heating air velocity distribution

◆ Discharge angle : 52°

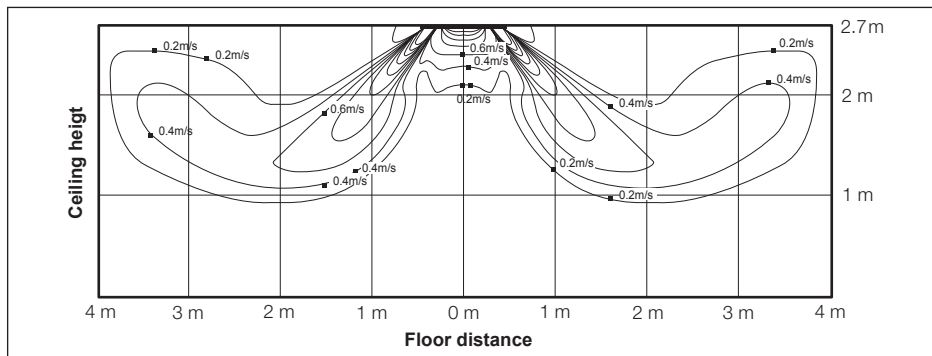

(4) Heating temperature distribution

◆ Discharge angle : 52°

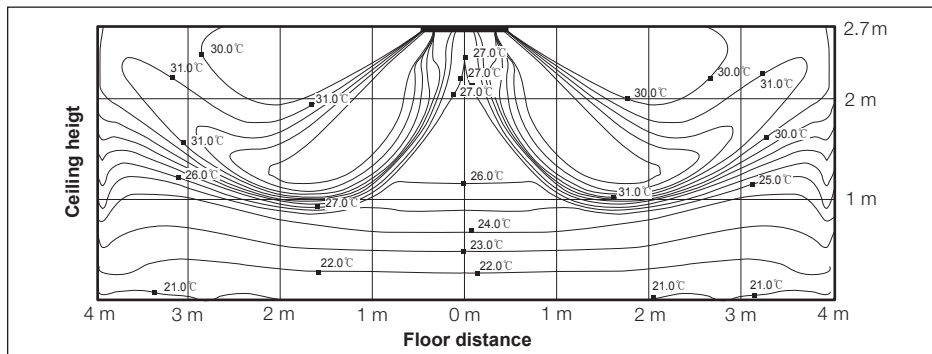

4 4 way cassette S

4-8. Temperature and air flow distribution

2) ND1124HXEA

(1) Cooling air velocity distribution

◆ Discharge angle : 45°

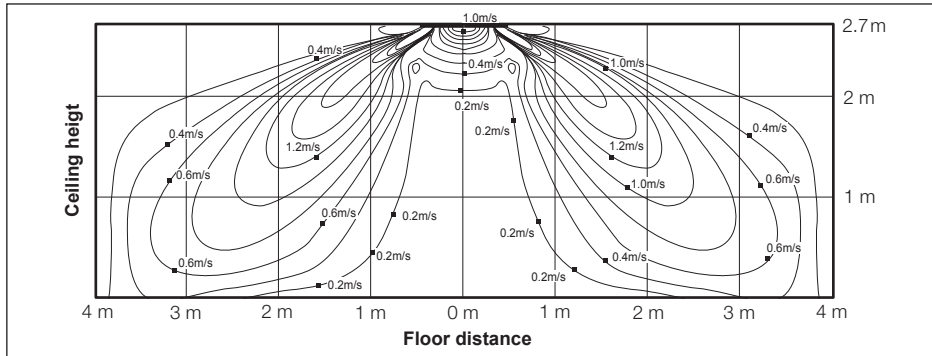

(2) Cooling temperature distribution

◆ Discharge angle : 45°

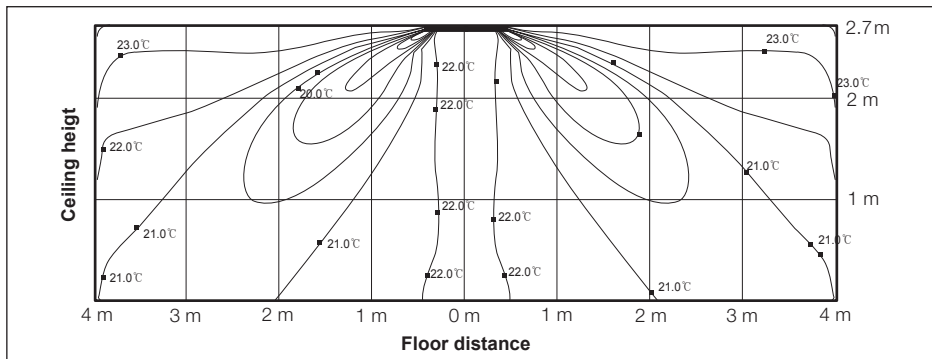

(3) Heating air velocity distribution

◆ Discharge angle : 52°

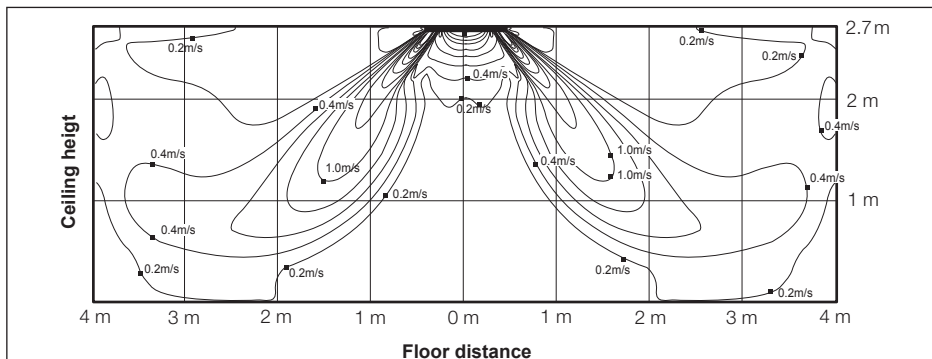

(4) Heating temperature distribution

◆ Discharge angle : 52°

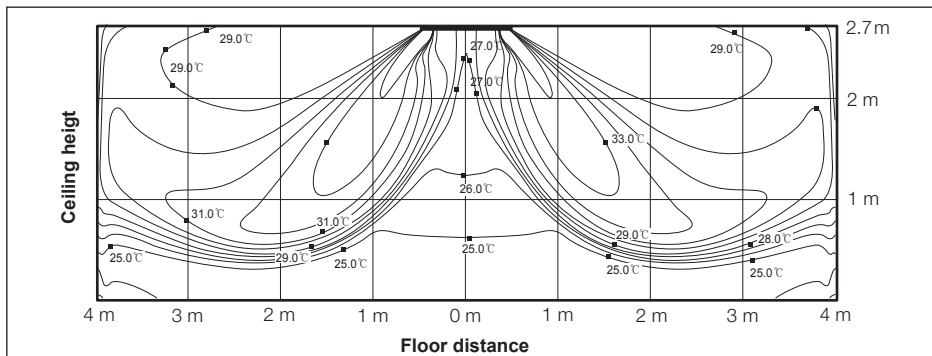

3) ND1404HXEA

(1) Cooling air velocity distribution

◆ Discharge angle : 45°

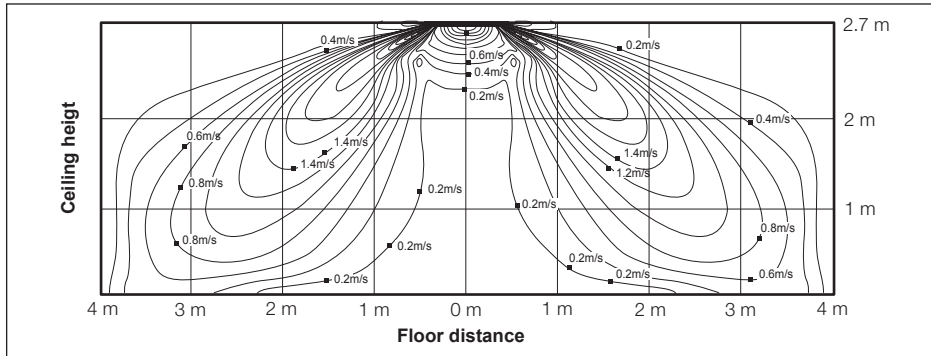

(2) Cooling temperature distribution

◆ Discharge angle : 45°

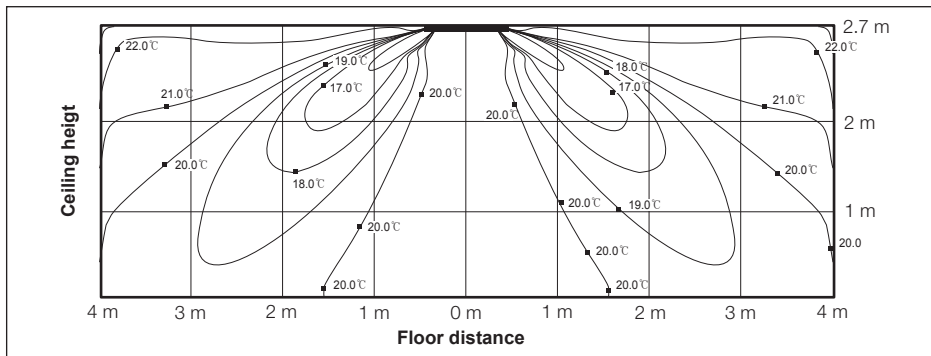

(3) Heating air velocity distribution

◆ Discharge angle : 52°

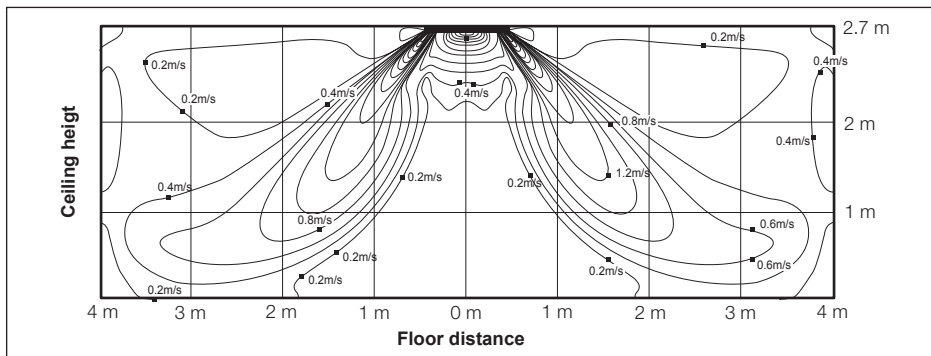

(4) Heating temperature distribution

◆ Discharge angle : 52°

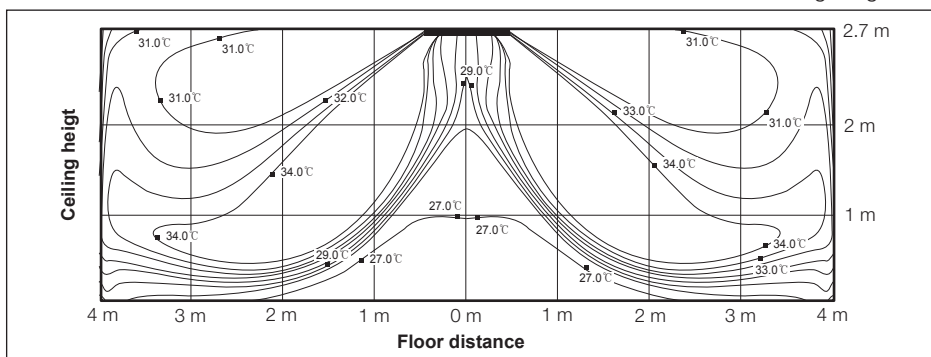



INDOOR UNIT



5 Slim duct (ND***LHXEA)

5-1. Specifications.....	60
5-2. Capacity tables	62
5-3. Dimensional drawing.....	66
5-4. PCB connector lay-out.....	69
5-5. Electrical wiring diagram	71
5-6. Sound pressure level	73
5-7. Recommended operation range	75

Optional Accessories

Individual Controllers



MWR-WE10



MWR-WH00



MWR-SH00



MR-DH00



MRK-A00



MRW-10A

Drain Pump



MDP-E075SEE3

5 Slim duct

5-1. Specifications

1) Technical specifications

Model			ND022LHXEA	ND028LHXEA	ND036LHXEA	ND045LHXEA	ND056LHXEA	
Power Supply			Ø, #, V, Hz	1, 2, 220~240, 50	1, 2, 220~240, 50	1, 2, 220~240, 50	1, 2, 220~240, 50	
Mode ^{*1)}			-	HP / HR	HP / HR	HP / HR	HP / HR	
Capacity (Nominal)	Cooling ^{*2)}	kW	2.2	2.8	3.6	4.5	5.6	
		Btu/h	7,500	9,600	12,300	15,400	19,100	
	Heating ^{*3)}	kW	2.5	3.2	4.0	5.0	6.3	
		Btu/h	8,500	10,900	13,600	17,100	21,500	
Power	Power Input (Nominal)	Cooling ^{*2)}	W	80	80	80	90	100
		Heating ^{*3)}	W	80	80	80	90	100
	Current Input (Nominal)	Cooling ^{*2)}	A	0.40	0.40	0.40	0.60	0.60
		Heating ^{*3)}	A	0.40	0.40	0.40	0.60	0.60
Fan	Motor	Type	-	Sirocco Fan / SSR	Sirocco Fan / SSR	Sirocco Fan / SSR	Sirocco Fan / SSR	Sirocco Fan / SSR
		Output	W					
		Number of unit	EA	1	1	1	1	1
	Air Flow Rate	H/M/L (UL)	CMM	8 / 7 / 6	9 / 8 / 7	10 / 8.5 / 7	14.5 / 13 / 11.5	15.5 / 14 / 12.5
			CFM	280 / 250 / 210	320 / 280 / 250	350 / 300 / 250	510 / 460 / 410	550 / 490 / 440
	External Pressure	Min / Std / Max	mmAq	0 / 2 / 4	0 / 2 / 4	0 / 2 / 4	0 / 2 / 4	0 / 2 / 4
Pa			0 / 19.6 / 39.2	0 / 19.6 / 39.2	0 / 19.6 / 39.2	0 / 19.6 / 39.2	0 / 19.6 / 39.2	
WG			0 / 0.079 / 0.157	0 / 0.079 / 0.157	0 / 0.079 / 0.157	0 / 0.079 / 0.157	0 / 0.079 / 0.157	
Option Code			-	015201-1200EA-200000-300000	015201-14022C-200000-300000	015201-1603A0-200000-300000	015223-170135-200000-300000	015223-1901BA-200000-300000
Piping Connections	Liquid Pipe	Ø, mm	6.35	6.35	6.35	6.35	6.35	
		Ø, inch	1/4	1/4	1/4	1/4	1/4	
	Gas Pipe	Ø, mm	12.7	12.7	12.7	12.7	12.7	
		Ø, inch	1/2	1/2	1/2	1/2	1/2	
Drain Pipe	Ø, mm	ID25 Hose (OD 32, ID 25)	ID25 Hose (OD 32, ID 25)	ID25 Hose (OD 32, ID 25)	ID25 Hose (OD 32, ID 25)	ID25 Hose (OD 32, ID 25)		
Field Wiring	Power Source Wire	Below 20m / over 20m	mm ²	1.5 / 2.5	1.5 / 2.5	1.5 / 2.5	1.5 / 2.5	1.5 / 2.5
	Transmission Cable		mm ²	0.75 / 1.5	0.75 / 1.5	0.75 / 1.5	0.75 / 1.5	0.75 / 1.5
Refrigerant	Type	-	R410A	R410A	R410A	R410A	R410A	
	Control Method	-	EEV	EEV	EEV	EEV	EEV	
Sound	Sound Pressure	High / Low ^{*4)}	dBA	31 / 26	32 / 27	32 / 27	33 / 30	33 / 30
Dimensions	Net Weight		kg	26	26	26	31	31
	Shipping Weight		kg	31	31	31	39	39
	Net Dimensions (W×H×D)		mm	900 x 199 x 600	900 x 199 x 600	900 x 199 x 600	1,100 x 199 x 600	1,100 x 199 x 600
	Shipping Dimensions (W×H×D)		mm	1,133 x 330 x 730	1,133 x 330 x 730	1,133 x 330 x 730	1,330 x 330 x 730	1,330 x 330 x 730
Panel Size	Panel model		-	-	-	-	-	-
	Panel Net Weight		kg	-	-	-	-	-
	Shipping Weight		kg	-	-	-	-	-
	Net Dimensions (W×H×D)		mm	-	-	-	-	-
	Shipping Dimensions (W×H×D)		mm	-	-	-	-	-
Additional Accessories	Drain pump	Drain pump	- / Model	Optional / MDP-E075SEE3	Optional / MDP-E075SEE3	Optional / MDP-E075SEE3	Optional / MDP-E075SEE3	Optional / MDP-E075SEE3
		Max. lifting Height / Displacement	mm/liter/h	750 / 24	750 / 24	750 / 24	750 / 24	750 / 24
	Air Filter		-	Long life filter	Long life filter	Long life filter	Long life filter	Long life filter

* Specifications may be subject to change without prior notice for product improvement.

***1) Mode**

- HP : Heat Pump, HR : Heat Recovery

***2) Nominal cooling capacities are based on;**

- Indoor temperature : 27°C DB, 19°C WB

- Outdoor temperature : 35°C DB, 24°C WB, Equivalent refrigerant piping : 7.5m, Level differences : 0m

***3) Nominal heating capacities are based on;**

- Indoor temperature : 20°C DB, 15°C WB

- Outdoor temperature : 7°C DB, 6°C WB, Equivalent refrigerant piping : 7.5m, Level differences : 0m

***4) Sound pressure was acquired in a dead room. Thus actual noise level may be different depending on the installation conditions.**

Model				ND071LHXEA	ND090LHXEA	ND112LHXEA	ND128LHXEA	ND140LHXEA	
Power Supply			Ø, #, V, Hz	1, 2, 220~240, 50	1, 2, 220~240, 50	1, 2, 220~240, 50	1, 2, 220~240, 50	1, 2, 220~240, 50	
Mode*1)			-	HP / HR	HP / HR	HP / HR	HP / HR	HP / HR	
Capacity (Nominal)	Cooling*2)	kW		7.1	9.0	11.2	12.8	14.0	
		Btu/h		24,200	30,700	38,200	43,700	47,800	
	Heating*3)	kW		8.0	10.0	12.5	13.8	16.0	
		Btu/h		27,300	34,100	42,700	47,100	54,600	
Power	Power Input (Nominal)	Cooling*2)	W	120	170	170	200	220	
		Heating*3)	W	120	170	170	200	220	
	Current Input (Nominal)	Cooling*2)	A	0.60	0.96	0.96	1.13	1.24	
		Heating*3)	A	0.60	0.96	0.96	1.13	1.24	
Fan	Motor	Type	-	Sirocco Fan / SSR	Sirocco Fan / BLDC	Sirocco Fan / BLDC	Sirocco Fan / BLDC	Sirocco Fan / BLDC	
		Output	W						
		Number of unit	EA	1	1	1	1	1	
	Air Flow Rate	H/M/L (UL)	CMM		16.5 / 15 / 13.5	29 / 27 / 25	31.2 / 29 / 27	34 / 32 / 30	36 / 34 / 32
			CFM		580 / 530 / 480	1020 / 950 / 880	1100 / 1020 / 950	1200 / 1130 / 1060	1270 / 1200 / 1130
	External Pressure	Min / Std / Max	mmAq		0 / 2 / 4	0 / 3 / 6	0 / 3 / 6	0 / 3 / 6	0 / 3 / 6
Pa				0 / 19.6 / 39.2	0 / 29.4 / 58.8	0 / 29.4 / 58.8	0 / 29.4 / 58.8	0 / 29.4 / 58.8	
WG				0 / 0.079 / 0.157	0 / 0.118 / 0.236	0 / 0.118 / 0.236	0 / 0.118 / 0.236	0 / 0.118 / 0.236	
Option Code			-	015223-1C039E-200000-300000	015214-1E00D4-200000-300000	015A14-1000D4-200000-300000	015A14-12024B-200000-300000	015A14-13027F-200000-300000	
Piping Connections	Liquid Pipe	Ø, mm		9.52	9.52	9.52	9.52	9.52	
		Ø, inch		3/8	3/8	3/8	3/8	3/8	
	Gas Pipe	Ø, mm		15.88	15.88	15.88	15.88	15.88	
		Ø, inch		5/8	5/8	5/8	5/8	5/8	
Drain Pipe	Ø, mm	ID25 Hose (OD 32, ID 25)	ID25 Hose (OD 32, ID 25)	ID25 Hose (OD 32, ID 25)	ID25 Hose (OD 32, ID 25)	ID25 Hose (OD 32, ID 25)	ID25 Hose (OD 32, ID 25)		
Field Wiring	Power Source Wire	Below 20m / over 20m	mm ²	1.5 / 2.5	1.5 / 2.5	1.5 / 2.5	1.5 / 2.5	1.5 / 2.5	
	Transmission Cable		mm ²	0.75 / 1.5	0.75 / 1.5	0.75 / 1.5	0.75 / 1.5	0.75 / 1.5	
Refrigerant	Type	-		R410A	R410A	R410A	R410A	R410A	
	Control Method	-		EEV	EEV	EEV	EEV	EEV	
Sound	Sound Pressure	High / Low*4)	dBA	36 / 32	40 / 36	40 / 36	41 / 38	41 / 38	
Dimensions	Net Weight		kg	31	43	43	46	46	
	Shipping Weight		kg	39	52	52	55	55	
	Net Dimensions (WxHxD)		mm	1,100 x 199 x 600	1,300 x 295 x 690	1,300 x 295 x 690	1,300 x 295 x 690	1,300 x 295 x 690	
	Shipping Dimensions (WxHxD)		mm	1,330 x 330 x 730	1,600 x 444 x 831	1,600 x 444 x 831	1,600 x 444 x 831	1,600 x 444 x 831	
Panel Size	Panel model		-	-	-	-	-	-	
	Panel Net Weight		kg	-	-	-	-	-	
	Shipping Weight		kg	-	-	-	-	-	
	Net Dimensions (WxHxD)		mm	-	-	-	-	-	
	Shipping Dimensions (WxHxD)		mm	-	-	-	-	-	
Additional Accessories	Drain pump	Drain pump	- / Model	Optional / MDP-E075SEE3	Optional / MDP-E075SEE3	Optional / MDP-E075SEE3	Optional / MDP-E075SEE3	Optional / MDP-E075SEE3	
		Max. lifting Height / Displacement	mm/liter/h	750 / 24	750 / 24	750 / 24	750 / 24	750 / 24	
	Air Filter		-		Long life filter	Long life filter	Long life filter	Long life filter	Long life filter

* Specifications may be subject to change without prior notice for product improvement.

*1) Mode

- HP : Heat Pump, HR : Heat Recovery

*2) Nominal cooling capacities are based on;

- Indoor temperature : 27°C DB, 19°C WB

- Outdoor temperature : 35°C DB, 24°C WB, Equivalent refrigerant piping : 7.5m, Level differences : 0m

*3) Nominal heating capacities are based on;

- Indoor temperature : 20°C DB, 15°C WB

- Outdoor temperature : 7°C DB, 6°C WB, Equivalent refrigerant piping : 7.5m, Level differences : 0m

*4) Sound pressure was acquired in a dead room. Thus actual noise level may be different depending on the installation conditions.

5 Slim duct

5-2. Capacity tables

1) Cooling

TC : Total Capacity(kW), SHC : Sensible Heat Capacity(kW)

Model	Outdoor temperature (°C, DB)	Indoor temperature (°C, WB)													
		20 (°C, DB) 14 (°C, WB)		23 (°C, DB) 16 (°C, WB)		26 (°C, DB) 18 (°C, WB)		27 (°C, DB) 19 (°C, WB)		28 (°C, DB) 20 (°C, WB)		30 (°C, DB) 22 (°C, WB)		32 (°C, DB) 24 (°C, WB)	
		TC	SHC	TC	SHC	TC	SHC	TC	SHC	TC	SHC	TC	SHC	TC	SHC
022	10	1.5	1.3	1.8	1.5	2.1	1.7	2.2	1.7	2.3	1.7	2.5	1.8	2.6	1.6
	12	1.5	1.3	1.8	1.5	2.1	1.7	2.2	1.7	2.3	1.7	2.5	1.8	2.6	1.6
	14	1.5	1.3	1.8	1.5	2.1	1.7	2.2	1.7	2.3	1.7	2.5	1.8	2.6	1.6
	16	1.5	1.3	1.8	1.5	2.1	1.7	2.2	1.7	2.3	1.7	2.4	1.7	2.6	1.6
	18	1.5	1.3	1.8	1.5	2.1	1.7	2.2	1.7	2.3	1.7	2.4	1.7	2.6	1.6
	20	1.5	1.3	1.8	1.5	2.1	1.7	2.2	1.7	2.3	1.7	2.4	1.7	2.6	1.6
	21	1.5	1.3	1.8	1.5	2.1	1.7	2.2	1.7	2.3	1.7	2.4	1.7	2.6	1.6
	23	1.5	1.3	1.8	1.5	2.1	1.7	2.2	1.7	2.3	1.7	2.4	1.7	2.6	1.6
	25	1.5	1.3	1.8	1.5	2.1	1.7	2.2	1.7	2.3	1.7	2.4	1.7	2.6	1.6
	27	1.5	1.3	1.8	1.5	2.1	1.7	2.2	1.7	2.3	1.7	2.4	1.7	2.6	1.6
	29	1.5	1.3	1.8	1.5	2.1	1.7	2.2	1.7	2.3	1.7	2.4	1.7	2.6	1.6
	31	1.5	1.3	1.8	1.5	2.1	1.7	2.2	1.7	2.3	1.7	2.4	1.7	2.6	1.6
	33	1.5	1.3	1.8	1.5	2.1	1.7	2.2	1.7	2.3	1.7	2.4	1.7	2.6	1.6
	35	1.5	1.3	1.8	1.5	2.1	1.7	2.2	1.7	2.3	1.7	2.4	1.7	2.6	1.6
	37	1.5	1.3	1.8	1.5	2.1	1.7	2.2	1.7	2.3	1.7	2.4	1.7	2.6	1.6
39	1.5	1.3	1.8	1.5	2.1	1.7	2.2	1.7	2.3	1.7	2.4	1.7	2.5	1.5	
42	1.5	1.3	1.8	1.5	2.1	1.7	2.1	1.6	2.2	1.6	2.3	1.6	2.4	1.4	
44	1.5	1.3	1.8	1.5	2.0	1.6	2.1	1.6	2.1	1.5	2.2	1.5	2.2	1.3	
028	10	1.9	1.7	2.3	1.9	2.6	2.0	2.8	2.1	2.9	2.1	3.1	2.1	3.4	2.1
	12	1.9	1.7	2.3	1.9	2.6	2.0	2.8	2.1	2.9	2.1	3.1	2.1	3.3	2.0
	14	1.9	1.7	2.3	1.9	2.6	2.0	2.8	2.1	2.9	2.1	3.1	2.1	3.3	2.0
	16	1.9	1.7	2.3	1.9	2.6	2.0	2.8	2.1	2.9	2.1	3.1	2.1	3.3	2.0
	18	1.9	1.7	2.3	1.9	2.6	2.0	2.8	2.1	2.9	2.1	3.1	2.1	3.3	2.0
	20	1.9	1.7	2.3	1.9	2.6	2.0	2.8	2.1	2.9	2.1	3.1	2.1	3.3	2.0
	21	1.9	1.7	2.3	1.9	2.6	2.0	2.8	2.1	2.9	2.1	3.1	2.1	3.3	2.0
	23	1.9	1.7	2.3	1.9	2.6	2.0	2.8	2.1	2.9	2.1	3.1	2.1	3.3	2.0
	25	1.9	1.7	2.3	1.9	2.6	2.0	2.8	2.1	2.9	2.1	3.1	2.1	3.3	2.0
	27	1.9	1.7	2.3	1.9	2.6	2.0	2.8	2.1	2.9	2.1	3.1	2.1	3.3	2.0
	29	1.9	1.7	2.3	1.9	2.6	2.0	2.8	2.1	2.9	2.1	3.1	2.1	3.3	2.0
	31	1.9	1.7	2.3	1.9	2.6	2.0	2.8	2.1	2.9	2.1	3.1	2.1	3.3	2.0
	33	1.9	1.7	2.3	1.9	2.6	2.0	2.8	2.1	2.9	2.1	3.1	2.1	3.3	2.0
	35	1.9	1.7	2.3	1.9	2.6	2.0	2.8	2.1	2.9	2.1	3.1	2.1	3.3	2.0
	37	1.9	1.7	2.3	1.9	2.6	2.0	2.8	2.1	2.9	2.1	3.1	2.1	3.3	2.0
39	1.9	1.7	2.3	1.9	2.6	2.0	2.8	2.1	2.9	2.1	3.0	2.0	3.2	1.9	
42	1.9	1.7	2.3	1.9	2.6	2.0	2.7	2.0	2.8	2.1	2.9	1.9	3.0	1.8	
44	1.9	1.7	2.3	1.9	2.5	1.9	2.7	2.0	2.7	2.0	2.7	1.8	2.8	1.7	
036	10	2.5	2.2	2.9	2.5	3.4	2.7	3.6	2.8	3.7	2.8	4.0	2.8	4.3	2.7
	12	2.5	2.2	2.9	2.5	3.4	2.7	3.6	2.8	3.7	2.8	4.0	2.8	4.3	2.7
	14	2.5	2.2	2.9	2.5	3.4	2.7	3.6	2.8	3.7	2.8	4.0	2.8	4.3	2.7
	16	2.5	2.2	2.9	2.5	3.4	2.7	3.6	2.8	3.7	2.8	4.0	2.8	4.3	2.7
	18	2.5	2.2	2.9	2.5	3.4	2.7	3.6	2.8	3.7	2.8	4.0	2.8	4.3	2.7
	20	2.5	2.2	2.9	2.5	3.4	2.7	3.6	2.8	3.7	2.8	4.0	2.8	4.2	2.6
	21	2.5	2.2	2.9	2.5	3.4	2.7	3.6	2.8	3.7	2.8	4.0	2.8	4.2	2.6
	23	2.5	2.2	2.9	2.5	3.4	2.7	3.6	2.8	3.7	2.8	4.0	2.8	4.2	2.6
	25	2.5	2.2	2.9	2.5	3.4	2.7	3.6	2.8	3.7	2.8	4.0	2.8	4.2	2.6
	27	2.5	2.2	2.9	2.5	3.4	2.7	3.6	2.8	3.7	2.8	4.0	2.8	4.2	2.6
	29	2.5	2.2	2.9	2.5	3.4	2.7	3.6	2.8	3.7	2.8	4.0	2.8	4.2	2.6
	31	2.5	2.2	2.9	2.5	3.4	2.7	3.6	2.8	3.7	2.8	4.0	2.8	4.2	2.6
	33	2.5	2.2	2.9	2.5	3.4	2.7	3.6	2.8	3.7	2.8	4.0	2.8	4.2	2.6
	35	2.5	2.2	2.9	2.5	3.4	2.7	3.6	2.8	3.7	2.8	4.0	2.8	4.2	2.6
	37	2.5	2.2	2.9	2.5	3.4	2.7	3.6	2.8	3.7	2.8	3.9	2.7	4.2	2.6
39	2.5	2.2	2.9	2.5	3.4	2.7	3.6	2.8	3.7	2.8	3.9	2.7	4.1	2.5	
42	2.5	2.2	2.9	2.5	3.4	2.7	3.5	2.7	3.6	2.6	3.7	2.6	3.9	2.4	
44	2.5	2.2	2.9	2.5	3.2	2.6	3.4	2.6	3.5	2.5	3.5	2.5	3.6	2.3	
045	10	3.1	2.8	3.7	3.2	4.2	3.3	4.5	3.4	4.7	3.4	5.0	3.4	5.4	3.5
	12	3.1	2.8	3.7	3.2	4.2	3.3	4.5	3.4	4.7	3.4	5.0	3.4	5.4	3.5
	14	3.1	2.8	3.7	3.2	4.2	3.3	4.5	3.4	4.7	3.4	5.0	3.4	5.4	3.5
	16	3.1	2.8	3.7	3.2	4.2	3.3	4.5	3.4	4.7	3.4	5.0	3.4	5.3	3.2
	18	3.1	2.8	3.7	3.2	4.2	3.3	4.5	3.4	4.7	3.4	5.0	3.4	5.3	3.2
	20	3.1	2.8	3.7	3.2	4.2	3.3	4.5	3.4	4.7	3.4	5.0	3.4	5.3	3.2
	21	3.1	2.8	3.7	3.2	4.2	3.3	4.5	3.4	4.7	3.4	5.0	3.4	5.3	3.2
	23	3.1	2.8	3.7	3.2	4.2	3.3	4.5	3.4	4.7	3.4	5.0	3.4	5.3	3.2
	25	3.1	2.8	3.7	3.2	4.2	3.3	4.5	3.4	4.7	3.4	5.0	3.4	5.3	3.2
	27	3.1	2.8	3.7	3.2	4.2	3.3	4.5	3.4	4.7	3.4	5.0	3.4	5.3	3.2
	29	3.1	2.8	3.7	3.2	4.2	3.3	4.5	3.4	4.7	3.4	5.0	3.4	5.3	3.2
	31	3.1	2.8	3.7	3.2	4.2	3.3	4.5	3.4	4.7	3.4	5.0	3.4	5.3	3.2
	33	3.1	2.8	3.7	3.2	4.2	3.3	4.5	3.4	4.7	3.4	5.0	3.4	5.3	3.2
	35	3.1	2.8	3.7	3.2	4.2	3.3	4.5	3.4	4.7	3.4	5.0	3.4	5.3	3.2
	37	3.1	2.8	3.7	3.2	4.2	3.3	4.5	3.4	4.6	3.3	4.9	3.3	5.2	3.2
39	3.1	2.8	3.7	3.2	4.2	3.3	4.5	3.4	4.6	3.3	4.9	3.3	5.1	3.1	
42	3.1	2.8	3.7	3.2	4.2	3.3	4.4	3.3	4.5	3.2	4.6	3.1	4.8	3.2	
44	3.1	2.8	3.7	3.2	4.0	3.2	4.3	3.2	4.3	3.1	4.4	3.0	4.5	3.1	
056	10	3.9	3.4	4.6	3.9	5.3	4.1	5.6	4.3	5.8	4.3	6.3	4.4	6.7	4.2
	12	3.9	3.4	4.6	3.9	5.3	4.1	5.6	4.3	5.8	4.3	6.3	4.4	6.7	4.2
	14	3.9	3.4	4.6	3.9	5.3	4.1	5.6	4.3	5.8	4.3	6.2	4.3	6.7	4.2
	16	3.9	3.4	4.6	3.9	5.3	4.1	5.6	4.3	5.8	4.3	6.2	4.3	6.6	4.1
	18	3.9	3.4	4.6	3.9	5.3	4.1	5.6	4.3	5.8	4.3	6.2	4.3	6.6	4.1
	20	3.9	3.4	4.6	3.9	5.3	4.1	5.6	4.3	5.8	4.3	6.2	4.3	6.6	4.1
	21	3.9	3.4	4.6	3.9	5.3	4.1	5.6	4.3	5.8	4.3	6.2	4.3	6.6	4.1
	23	3.9	3.4	4.6	3.9	5.3	4.1	5.6	4.3	5.8	4.3	6.2	4.3	6.6	4.1
	25	3.9	3.4	4.6	3.9	5.3	4.1	5.6	4.3	5.8	4.3	6.2	4.3	6.6	4.1
	27	3.9	3.4	4.6	3.9	5.3	4.1	5.6	4.3	5.8	4.3	6.2	4.3	6.6	4.1
	29	3.9	3.4	4.6	3.9	5.3	4.1	5.6	4.3	5.8	4.3	6.2	4.3	6.6	4.1
	31	3.9	3.4	4.6	3.9	5.3	4.1	5.6	4.3	5.8	4.3	6.2	4.3	6.6	4.1
	33	3.9	3.4	4.6	3.9	5.3	4.1	5.6	4.3	5.8	4.3	6.2	4.3	6.6	4.1
	35	3.9	3.4	4.6	3.9	5.3	4.1	5.6	4.3	5.8	4.3	6.2	4.3	6.6	4.1
	37	3.9	3.4	4.6	3.9	5.3	4.1	5.6	4.3	5.8	4.3	6.1	4.2	6.5	4.0
39	3.9	3.4	4.6	3.9	5.3	4.1	5.6	4.3	5.8	4.3	6.1	4.2	6.4	3.9	
42	3.9	3.4	4.6	3.9	5.3	4.1	5.4	4.2	5.6	4.2	5.8	4.1	6.0	3.7	
44	3.9	3.4	4.6	3.9	5.0	4.0	5.3	4.1	5.4	4.1	5.5	4.0	5.6	3.5	

TC : Total Capacity(kW), SHC : Sensible Heat Capacity(kW)

Model	Outdoor temperature (°C, DB)	Indoor temperature (°C, WB)													
		20 (°C, DB)		23 (°C, DB)		26 (°C, DB)		27 (°C, DB)		28 (°C, DB)		30 (°C, DB)		32 (°C, DB)	
		14 (°C, WB)		16 (°C, WB)		18 (°C, WB)		19 (°C, WB)		20 (°C, WB)		22 (°C, WB)		24 (°C, WB)	
		TC	SHC	TC	SHC	TC	SHC	TC	SHC	TC	SHC	TC	SHC	TC	SHC
071	10	4.9	4.3	5.8	5.0	6.7	5.2	7.1	5.4	7.4	5.6	8.0	5.7	8.5	5.4
	12	4.9	4.3	5.8	5.0	6.7	5.2	7.1	5.4	7.4	5.6	7.9	5.6	8.5	5.4
	14	4.9	4.3	5.8	5.0	6.7	5.2	7.1	5.4	7.4	5.6	7.9	5.6	8.5	5.4
	16	4.9	4.3	5.8	5.0	6.7	5.2	7.1	5.4	7.4	5.6	7.9	5.6	8.4	5.3
	18	4.9	4.3	5.8	5.0	6.7	5.2	7.1	5.4	7.4	5.6	7.9	5.6	8.4	5.3
	20	4.9	4.3	5.8	5.0	6.7	5.2	7.1	5.4	7.4	5.6	7.9	5.6	8.4	5.3
	21	4.9	4.3	5.8	5.0	6.7	5.2	7.1	5.4	7.4	5.6	7.9	5.6	8.4	5.3
	23	4.9	4.3	5.8	5.0	6.7	5.2	7.1	5.4	7.4	5.6	7.9	5.6	8.4	5.3
	25	4.9	4.3	5.8	5.0	6.7	5.2	7.1	5.4	7.4	5.6	7.9	5.6	8.4	5.3
	27	4.9	4.3	5.8	5.0	6.7	5.2	7.1	5.4	7.4	5.6	7.9	5.6	8.4	5.3
	29	4.9	4.3	5.8	5.0	6.7	5.2	7.1	5.4	7.4	5.6	7.9	5.6	8.4	5.3
	31	4.9	4.3	5.8	5.0	6.7	5.2	7.1	5.4	7.4	5.6	7.9	5.6	8.4	5.3
	33	4.9	4.3	5.8	5.0	6.7	5.2	7.1	5.4	7.4	5.6	7.9	5.6	8.4	5.3
	35	4.9	4.3	5.8	5.0	6.7	5.2	7.1	5.4	7.4	5.6	7.9	5.6	8.4	5.3
	37	4.9	4.3	5.8	5.0	6.7	5.2	7.1	5.4	7.3	5.5	7.8	5.5	8.2	5.2
39	4.9	4.3	5.8	5.0	6.7	5.2	7.1	5.4	7.3	5.5	7.7	5.4	8.1	5.1	
42	4.9	4.3	5.8	5.0	6.7	5.2	6.9	5.3	7.0	5.4	7.3	5.3	7.6	4.9	
44	4.9	4.3	5.8	5.0	6.3	5.0	6.7	5.2	6.8	5.3	7.0	5.2	7.1	4.7	
090	10	6.2	5.5	7.3	6.3	8.4	6.7	9.0	6.9	9.4	7.1	10.1	7.1	10.8	7.1
	12	6.2	5.5	7.3	6.3	8.4	6.7	9.0	6.9	9.4	7.1	10.1	7.1	10.8	7.1
	14	6.2	5.5	7.3	6.3	8.4	6.7	9.0	6.9	9.3	7.0	10.0	7.0	10.7	6.9
	16	6.2	5.5	7.3	6.3	8.4	6.7	9.0	6.9	9.3	7.0	10.0	7.0	10.7	6.9
	18	6.2	5.5	7.3	6.3	8.4	6.7	9.0	6.9	9.3	7.0	10.0	7.0	10.6	6.8
	20	6.2	5.5	7.3	6.3	8.4	6.7	9.0	6.9	9.3	7.0	10.0	7.0	10.6	6.8
	21	6.2	5.5	7.3	6.3	8.4	6.7	9.0	6.9	9.3	7.0	10.0	7.0	10.6	6.8
	23	6.2	5.5	7.3	6.3	8.4	6.7	9.0	6.9	9.3	7.0	10.0	7.0	10.6	6.8
	25	6.2	5.5	7.3	6.3	8.4	6.7	9.0	6.9	9.3	7.0	10.0	7.0	10.6	6.8
	27	6.2	5.5	7.3	6.3	8.4	6.7	9.0	6.9	9.3	7.0	10.0	7.0	10.6	6.8
	29	6.2	5.5	7.3	6.3	8.4	6.7	9.0	6.9	9.3	7.0	10.0	7.0	10.6	6.8
	31	6.2	5.5	7.3	6.3	8.4	6.7	9.0	6.9	9.3	7.0	10.0	7.0	10.6	6.8
	33	6.2	5.5	7.3	6.3	8.4	6.7	9.0	6.9	9.3	7.0	10.0	7.0	10.6	6.8
	35	6.2	5.5	7.3	6.3	8.4	6.7	9.0	6.9	9.3	7.0	10.0	7.0	10.6	6.8
	37	6.2	5.5	7.3	6.3	8.4	6.7	9.0	6.9	9.3	7.0	9.9	6.9	10.4	6.7
39	6.2	5.5	7.3	6.3	8.4	6.7	9.0	6.9	9.2	6.9	9.7	6.8	10.2	6.6	
42	6.2	5.5	7.3	6.3	8.4	6.7	8.7	6.7	8.9	6.8	9.3	6.6	9.6	6.4	
44	6.2	5.5	7.3	6.3	8.0	6.5	8.6	6.6	8.6	6.7	8.8	6.4	9.0	6.2	
112	10	7.7	6.8	9.1	7.7	10.5	8.2	11.2	8.6	11.6	8.8	12.5	8.9	13.4	8.6
	12	7.7	6.8	9.1	7.7	10.5	8.2	11.2	8.6	11.6	8.8	12.5	8.9	13.4	8.6
	14	7.7	6.8	9.1	7.7	10.5	8.2	11.2	8.6	11.6	8.8	12.5	8.9	13.4	8.6
	16	7.7	6.8	9.1	7.7	10.5	8.2	11.2	8.6	11.6	8.8	12.5	8.9	13.3	8.5
	18	7.7	6.8	9.1	7.7	10.5	8.2	11.2	8.6	11.6	8.8	12.5	8.9	13.3	8.5
	20	7.7	6.8	9.1	7.7	10.5	8.2	11.2	8.6	11.6	8.8	12.4	8.8	13.2	8.5
	21	7.7	6.8	9.1	7.7	10.5	8.2	11.2	8.6	11.6	8.8	12.4	8.8	13.2	8.5
	23	7.7	6.8	9.1	7.7	10.5	8.2	11.2	8.6	11.6	8.8	12.4	8.8	13.2	8.5
	25	7.7	6.8	9.1	7.7	10.5	8.2	11.2	8.6	11.6	8.8	12.4	8.8	13.2	8.5
	27	7.7	6.8	9.1	7.7	10.5	8.2	11.2	8.6	11.6	8.8	12.4	8.8	13.2	8.5
	29	7.7	6.8	9.1	7.7	10.5	8.2	11.2	8.6	11.6	8.8	12.4	8.8	13.2	8.5
	31	7.7	6.8	9.1	7.7	10.5	8.2	11.2	8.6	11.6	8.8	12.4	8.8	13.2	8.5
	33	7.7	6.8	9.1	7.7	10.5	8.2	11.2	8.6	11.6	8.8	12.4	8.8	13.2	8.5
	35	7.7	6.8	9.1	7.7	10.5	8.2	11.2	8.6	11.6	8.8	12.4	8.7	13.2	8.5
	37	7.7	6.8	9.1	7.7	10.5	8.2	11.2	8.6	11.6	8.8	12.4	8.9	13.2	8.5
39	7.7	6.8	9.1	7.7	10.5	8.2	11.2	8.6	11.6	8.8	12.3	8.8	13.0	8.4	
42	7.7	6.8	9.1	7.7	10.5	8.2	11.2	8.6	11.5	8.7	12.1	8.7	12.7	8.2	
44	7.7	6.8	9.1	7.7	10.0	8.0	10.6	8.3	10.8	8.2	11.0	8.2	11.2	8.0	
128	10	8.8	7.7	10.4	8.8	12.0	9.4	12.8	9.8	13.3	9.8	14.3	9.9	15.4	9.8
	12	8.8	7.7	10.4	8.8	12.0	9.4	12.8	9.8	13.3	9.8	14.3	9.9	15.3	9.7
	14	8.8	7.7	10.4	8.8	12.0	9.4	12.8	9.8	13.3	9.8	14.3	9.9	15.3	9.7
	16	8.8	7.7	10.4	8.8	12.0	9.4	12.8	9.8	13.3	9.8	14.2	9.8	15.2	9.7
	18	8.8	7.7	10.4	8.8	12.0	9.4	12.8	9.8	13.3	9.8	14.2	9.8	15.1	9.6
	20	8.8	7.7	10.4	8.8	12.0	9.4	12.8	9.8	13.3	9.8	14.2	9.8	15.1	9.6
	21	8.8	7.7	10.4	8.8	12.0	9.4	12.8	9.8	13.3	9.8	14.2	9.8	15.1	9.6
	23	8.8	7.7	10.4	8.8	12.0	9.4	12.8	9.8	13.3	9.8	14.2	9.8	15.1	9.6
	25	8.8	7.7	10.4	8.8	12.0	9.4	12.8	9.8	13.3	9.8	14.2	9.8	15.1	9.6
	27	8.8	7.7	10.4	8.8	12.0	9.4	12.8	9.8	13.3	9.8	14.2	9.8	15.1	9.6
	29	8.8	7.7	10.4	8.8	12.0	9.4	12.8	9.8	13.3	9.8	14.2	9.8	15.1	9.6
	31	8.8	7.7	10.4	8.8	12.0	9.4	12.8	9.8	13.3	9.8	14.2	9.8	15.1	9.6
	33	8.8	7.7	10.4	8.8	12.0	9.4	12.8	9.8	13.3	9.8	14.2	9.8	15.1	9.6
	35	8.8	7.7	10.4	8.8	12.0	9.4	12.8	9.8	13.3	9.8	14.2	9.8	15.1	9.6
	37	8.8	7.7	10.4	8.8	12.0	9.4	12.8	9.8	13.2	9.8	14.0	9.7	14.9	9.5
39	8.8	7.7	10.4	8.8	12.0	9.4	12.8	9.8	13.1	9.7	13.8	9.5	14.5	9.3	
42	8.8	7.7	10.4	8.8	12.0	9.4	12.4	9.6	12.7	9.5	13.2	9.2	13.7	9.1	
44	8.8	7.7	10.4	8.8	11.4	9.1	12.2	9.5	12.3	9.3	12.5	8.6	12.8	8.9	
140	10	9.7	8.5	11.4	9.6	13.1	10.4	14.0	10.7	14.6	10.8	15.7	10.9	16.8	10.8
	12	9.7	8.5	11.4	9.6	13.1	10.4	14.0	10.7	14.5	10.7	15.6	10.8	16.7	10.7
	14	9.7	8.5	11.4	9.6	13.1	10.4	14.0	10.7	14.5	10.7	15.6	10.8	16.7	10.7
	16	9.7	8.5	11.4	9.6	13.1	10.4	14.0	10.7	14.5	10.7	15.6	10.8	16.6	10.6
	18	9.7	8.5	11.4	9.6	13.1	10.4	14.0	10.7	14.5	10.7	15.5	10.7	16.6	10.6
	20	9.7	8.5	11.4	9.6	13.1	10.4	14.0	10.7	14.5	10.7	15.5	10.7	16.5	10.5
	21	9.7	8.5	11.4	9.6	13.1	10.4	14.0	10.7	14.5	10.7	15.5	10.7	16.5	10.5
	23	9.7	8.5	11.4	9.6	13.1	10.4	14.0	10.7	14.5	10.7	15.5	10.7	16.5	10.5
	25	9.7	8.5	11.4	9.6	13.1	10.4	14.0	10.7	14.5	10.7	15.5	10.7	16.5	10.5
	27	9.7	8.5	11.4	9.6	13.1	10.4	14.0	10.7	14.5	10.7	15.5	10.7	16.5	10.5
	29	9.7	8.5	11.4	9.6	13.1	10.4	14.0	10.7	14.5	10.7	15.5	10.7	16.5	10.5
	31	9.7	8.5	11.4	9.6	13.1	10.4	14.0	10.7	14.5	10.7	15.5	10.7	16.5	10.5
	33	9.7	8.5	11.4	9.6	13.1	10.4	14.0	10.7	14.5	10.7	15.5	10.7	16.5	10.5
	35	9.7	8.5	11.4	9.6	13.1	10.4	14.0	10.7	14.5	10.7	15.5	10.7	16.5	10.5
	37	9.7	8.5	11.4	9.6	13.1	10.4	14.0	10.7	14.5	10.7	15.4	10.6	16.3	10.4
39	9.7	8.5	11.4	9.6	13.1	10.4	14.0	10.7	14.4	10.6	15.1	10.4	15.9	10.2	
42	9.7	8.5	11.4	9.6	13.1	10.4	13.6	10.5	13.9	10.3	14.4	10.0	15.0	9.8	
44	9.7	8.5	11.4	9.6	12.5	10.1	13.3	10.4	13.4	10.1	13.				

5-2. Capacity tables

2) Heating

TC : Total Capacity(kW)

Model	Outdoor temperature (°C)		Indoor temperature (°C, DB)				
			16.0	18.0	20.0	22.0	24.0
	DB	WB	TC	TC	TC	TC	TC
022	-20	-21	1.5	1.5	1.5	1.5	1.5
	-17	-18	1.6	1.6	1.6	1.6	1.6
	-15	-16	1.7	1.6	1.6	1.6	1.6
	-12	-13	1.8	1.8	1.8	1.8	1.7
	-10	-11	2.0	2.0	1.9	1.9	1.9
	-7	-8	2.3	2.2	2.2	2.0	2.0
	-5	-6	2.4	2.3	2.3	2.2	2.2
	-3	-4	2.5	2.5	2.4	2.3	2.2
	0	-1	2.6	2.5	2.5	2.3	2.2
	3	2.2	2.7	2.6	2.5	2.3	2.2
	5	4.1	2.8	2.7	2.5	2.3	2.2
	7	6	2.8	2.7	2.5	2.3	2.2
	9	7.9	3.0	2.7	2.5	2.3	2.2
	11	9.8	3.0	2.7	2.5	2.3	2.2
	13	12	3.0	2.7	2.5	2.3	2.2
15	14	3.0	2.7	2.5	2.3	2.2	
028	-20	-21	1.9	1.9	1.9	1.9	1.9
	-17	-18	2.0	2.0	2.0	2.0	1.9
	-15	-16	2.1	2.1	2.0	2.0	1.9
	-12	-13	2.2	2.2	2.2	2.1	2.1
	-10	-11	2.3	2.3	2.3	2.3	2.2
	-7	-8	2.5	2.4	2.4	2.4	2.3
	-5	-6	2.6	2.6	2.5	2.5	2.4
	-3	-4	2.8	2.7	2.7	2.6	2.5
	0	-1	2.9	2.8	2.8	2.7	2.6
	3	2.2	3.0	3.0	2.9	2.8	2.7
	5	4.1	3.2	3.1	3.1	2.9	2.7
	7	6	3.3	3.2	3.2	3.0	2.7
	9	7.9	3.4	3.3	3.2	3.0	2.7
	11	9.8	3.5	3.3	3.2	3.0	2.7
	13	12	3.6	3.4	3.2	3.0	2.7
15	14	3.7	3.4	3.2	3.0	2.7	
036	-20	-21	2.4	2.4	2.3	2.3	2.3
	-17	-18	2.6	2.5	2.4	2.4	2.3
	-15	-16	2.7	2.6	2.5	2.5	2.4
	-12	-13	2.8	2.7	2.7	2.6	2.6
	-10	-11	2.9	2.9	2.9	2.8	2.8
	-7	-8	3.1	3.1	3.0	3.0	2.9
	-5	-6	3.3	3.2	3.2	3.1	3.0
	-3	-4	3.4	3.4	3.3	3.2	3.1
	0	-1	3.6	3.6	3.5	3.4	3.2
	3	2.2	3.8	3.7	3.7	3.5	3.4
	5	4.1	3.9	3.9	3.8	3.6	3.4
	7	6	4.1	4.1	4.0	3.7	3.4
	9	7.9	4.2	4.1	4.0	3.7	3.4
	11	9.8	4.4	4.2	4.0	3.7	3.4
	13	12	4.5	4.2	4.0	3.7	3.4
15	14	4.6	4.3	4.0	3.7	3.4	
045	-20	-21	3.1	3.1	2.9	2.9	2.9
	-17	-18	3.2	3.2	3.1	3.0	3.0
	-15	-16	3.3	3.3	3.2	3.1	3.0
	-12	-13	3.5	3.4	3.4	3.3	3.2
	-10	-11	3.7	3.6	3.6	3.5	3.5
	-7	-8	3.9	3.8	3.8	3.7	3.6
	-5	-6	4.1	4.0	4.0	3.9	3.7
	-3	-4	4.3	4.2	4.2	4.0	3.9
	0	-1	4.5	4.4	4.4	4.2	4.0
	3	2.2	4.7	4.7	4.6	4.4	4.2
	5	4.1	4.9	4.9	4.8	4.5	4.2
	7	6	5.1	5.1	5.0	4.6	4.2
	9	7.9	5.3	5.2	5.0	4.6	4.2
	11	9.8	5.5	5.2	5.0	4.6	4.2
	13	12	5.6	5.3	5.0	4.6	4.2
15	14	5.8	5.4	5.0	4.6	4.2	
056	-20	-21	3.9	3.8	3.8	3.7	3.7
	-17	-18	4.0	4.0	3.9	3.8	3.8
	-15	-16	4.2	4.1	4.0	3.9	3.8
	-12	-13	4.4	4.3	4.2	4.2	4.1
	-10	-11	4.6	4.6	4.5	4.4	4.4
	-7	-8	4.9	4.8	4.8	4.7	4.5
	-5	-6	5.2	5.1	5.0	4.9	4.7
	-3	-4	5.4	5.3	5.3	5.1	4.9
	0	-1	5.7	5.6	5.5	5.3	5.0
	3	2.2	5.9	5.9	5.8	5.6	5.3
	5	4.1	6.2	6.1	6.0	5.7	5.3
	7	6	6.5	6.4	6.3	5.8	5.3
	9	7.9	6.7	6.5	6.3	5.8	5.3
	11	9.8	6.9	6.6	6.3	5.8	5.3
	13	12	7.1	6.7	6.3	5.8	5.3
15	14	7.3	6.8	6.3	5.8	5.3	

TC : Total Capacity(kW)

Model	Outdoor temperature (°C)		Indoor temperature (°C, DB)				
			16.0	18.0	20.0	22.0	24.0
	DB	WB	TC	TC	TC	TC	TC
071	-20	-21	4.9	4.9	4.8	4.7	4.7
	-17	-18	5.1	5.0	4.9	4.8	4.8
	-15	-16	5.3	5.2	5.1	4.9	4.8
	-12	-13	5.6	5.5	5.4	5.3	5.2
	-10	-11	5.9	5.8	5.7	5.6	5.6
	-7	-8	6.2	6.1	6.0	5.9	5.8
	-5	-6	6.5	6.5	6.4	6.2	6.0
	-3	-4	6.9	6.8	6.7	6.4	6.2
	0	-1	7.2	7.1	7.0	6.7	6.4
	3	2.2	7.6	7.5	7.3	7.1	6.8
	5	4.1	7.9	7.8	7.7	7.2	6.8
	7	6	8.2	8.1	8.0	7.4	6.8
	9	7.9	8.5	8.2	8.0	7.4	6.8
	11	9.8	8.7	8.4	8.0	7.4	6.8
	13	12	9.0	8.5	8.0	7.4	6.8
15	14	9.2	8.6	8.0	7.4	6.8	
090	-20	-21	6.0	6.0	5.9	5.8	5.8
	-17	-18	6.3	6.3	6.1	6.0	5.9
	-15	-16	6.7	6.5	6.3	6.1	6.0
	-12	-13	7.0	6.9	6.7	6.6	6.5
	-10	-11	7.3	7.2	7.1	7.0	7.0
	-7	-8	7.8	7.7	7.6	7.4	7.2
	-5	-6	8.2	8.1	8.0	7.7	7.5
	-3	-4	8.6	8.5	8.4	8.1	7.7
	0	-1	9.0	8.9	8.8	8.4	8.0
	3	2.2	9.4	9.3	9.2	8.8	8.4
	5	4.1	9.9	9.7	9.6	9.0	8.4
	7	6	10.3	10.1	10.0	9.2	8.4
	9	7.9	10.6	10.3	10.0	9.2	8.4
	11	9.8	10.9	10.5	10.0	9.2	8.4
	13	12	11.2	10.6	10.0	9.2	8.4
15	14	11.6	10.8	10.0	9.2	8.4	
112	-20	-21	7.4	7.4	7.3	7.3	7.3
	-17	-18	8.0	7.8	7.6	7.5	7.4
	-15	-16	8.4	8.1	7.9	7.7	7.5
	-12	-13	8.8	8.6	8.4	8.2	8.1
	-10	-11	9.2	9.0	8.9	8.8	8.7
	-7	-8	9.7	9.6	9.4	9.2	9.0
	-5	-6	10.2	10.1	9.9	9.6	9.3
	-3	-4	10.7	10.6	10.5	10.1	9.7
	0	-1	11.3	11.1	11.1	10.5	10.0
	3	2.2	11.8	11.6	11.5	11.0	10.6
	5	4.1	12.3	12.2	12.0	11.3	10.6
	7	6	12.9	12.7	12.5	11.5	10.6
	9	7.9	13.3	12.9	12.5	11.5	10.6
	11	9.8	13.7	13.1	12.5	11.5	10.6
	13	12	14.0	13.3	12.5	11.5	10.6
15	14	14.4	13.5	12.5	11.5	10.6	
128	-20	-21	8.1	8.1	8.0	8.0	8.0
	-17	-18	8.7	8.5	8.4	8.3	8.1
	-15	-16	9.2	9.0	8.7	8.5	8.2
	-12	-13	9.7	9.5	9.3	9.1	8.9
	-10	-11	10.1	10.0	9.9	9.7	9.6
	-7	-8	10.7	10.6	10.4	10.2	10.0
	-5	-6	11.3	11.1	11.0	10.7	10.3
	-3	-4	11.9	11.7	11.5	11.1	10.7
	0	-1	12.4	12.3	12.1	11.6	11.0
	3	2.2	13.0	12.9	12.7	12.2	11.7
	5	4.1	13.6	13.4	13.2	12.4	11.7
	7	6	14.2	14.0	13.8	12.7	11.7
	9	7.9	14.6	14.2	13.8	12.7	11.7
	11	9.8	15.1	14.4	13.8	12.7	11.7
	13	12	15.5	14.7	13.8	12.7	11.7
15	14	15.9	14.9	13.8	12.7	11.7	
140	-20	-21	9.5	9.5	9.4	9.4	9.3
	-17	-18	10.1	9.9	9.6	9.6	9.4
	-15	-16	10.7	10.4	10.1	9.8	9.5
	-12	-13	11.2	11.0	10.8	10.6	10.3
	-10	-11	11.7	11.6	11.4	11.3	11.1
	-7	-8	12.4	12.2	12.1	11.8	11.5
	-5	-6	13.1	12.9	12.7	12.3	12.0
	-3	-4	13.8	13.6	13.4	12.9	12.4
	0	-1	14.4	14.2	14.0	13.4	12.8
	3	2.2	15.1	14.9	14.7	14.1	13.5
	5	4.1	15.8	15.6	15.3	14.4	13.5
	7	6	16.5	16.2	16.0	14.8	13.5
	9	7.9	17.0	16.5	16.0	14.8	13.5
	11	9.8	17.5	16.7	16.0	14.8	13.5
	13	12	18.0	17.0	16.0	14.8	13.5
15	14	18.5	17.2	16.0	14.8	13.5	

Indoor units

5 Slim duct

5-3. Dimensional drawing

1) ND022/028/036LHXEA

Unit:mm

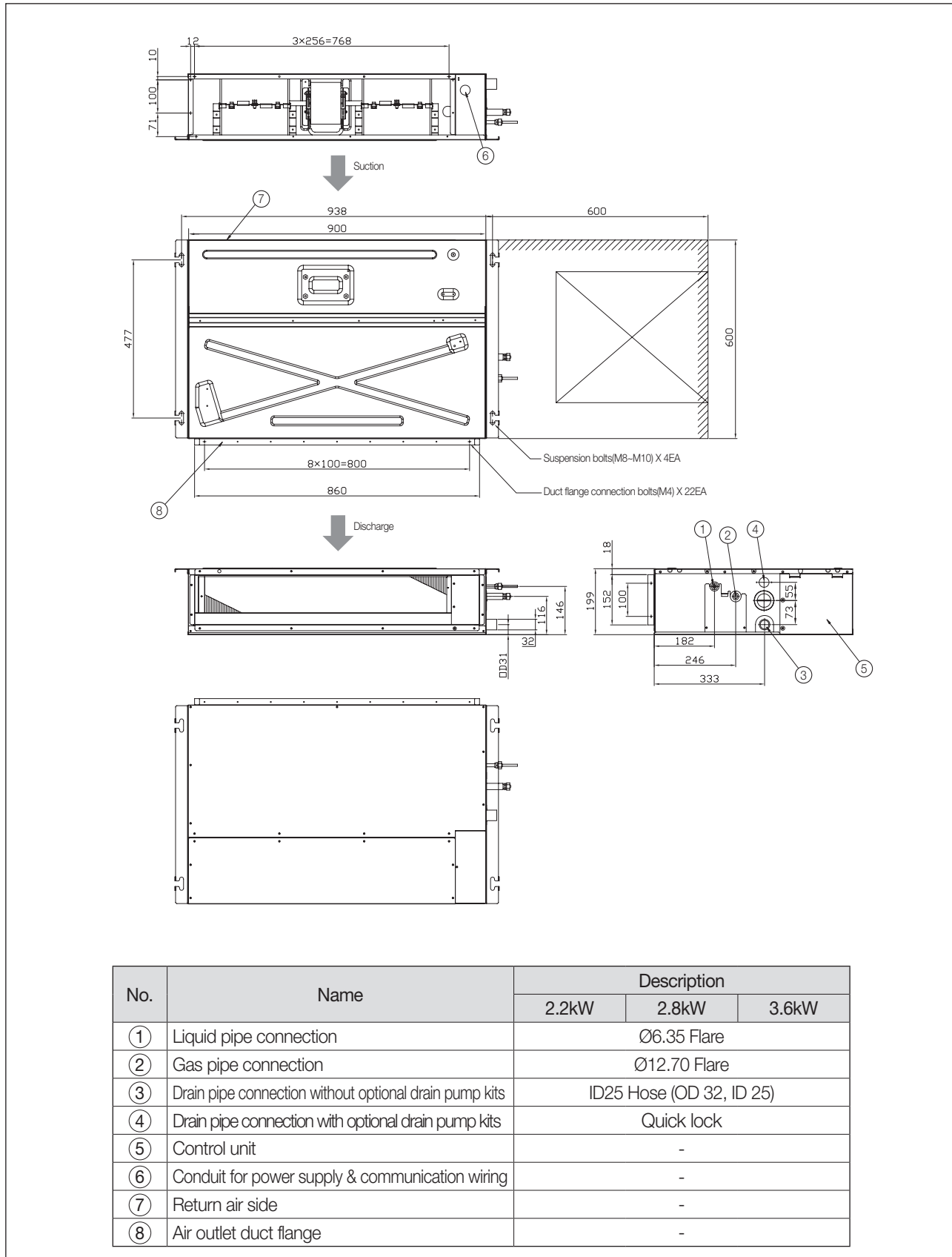

2) ND045/056/071LHXEA

Unit:mm

Indoor units

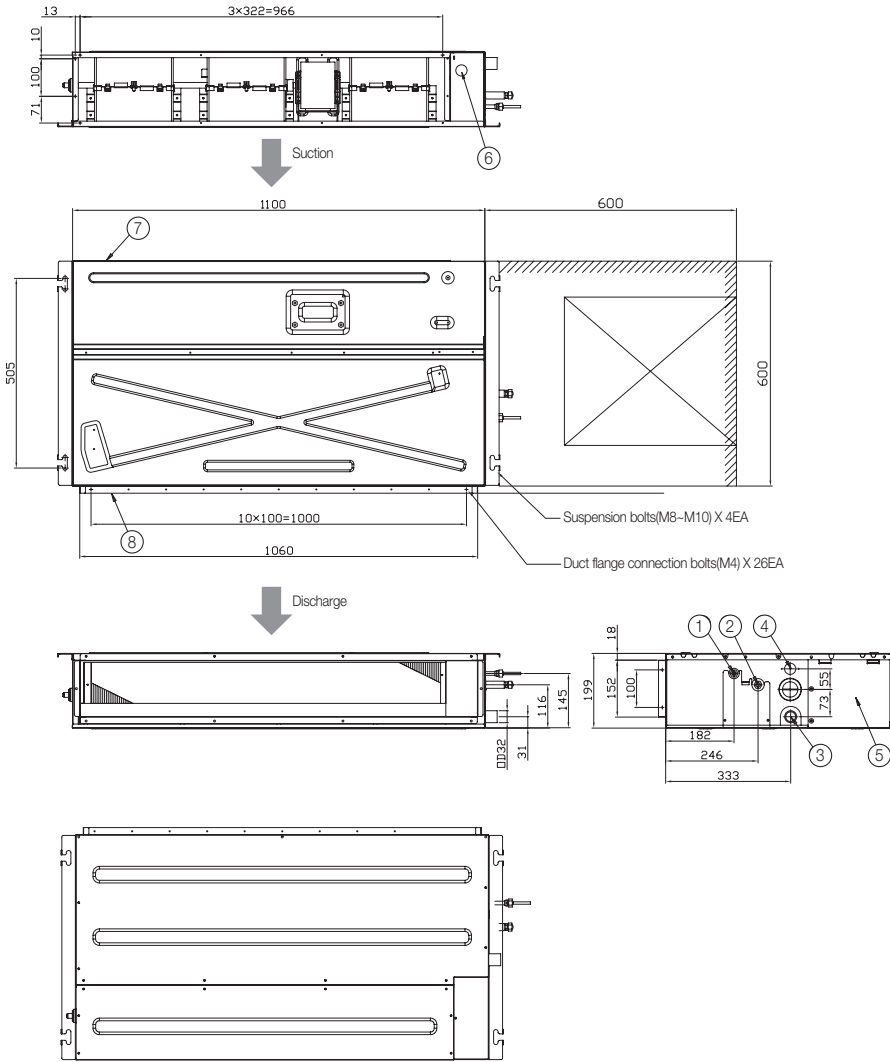

No.	Name	Description		
		4.5kW	5.6kW	7.1kW
①	Liquid pipe connection	Ø6.35 Flare		Ø9.52 Flare
②	Gas pipe connection	Ø12.70 Flare		Ø15.88 Flare
③	Drain pipe connection without optional drain pump kits	ID25 Hose (OD 32, ID 25)		
④	Drain pipe connection with optional drain pump kits	Quick lock		
⑤	Control unit	-		
⑥	Conduit for power supply & communication wiring	-		
⑦	Return air side	-		
⑧	Air outlet duct flange	-		

5 Slim duct

5-3. Dimensional drawing

3) ND090/112/128/140LHXEA

Unit:mm

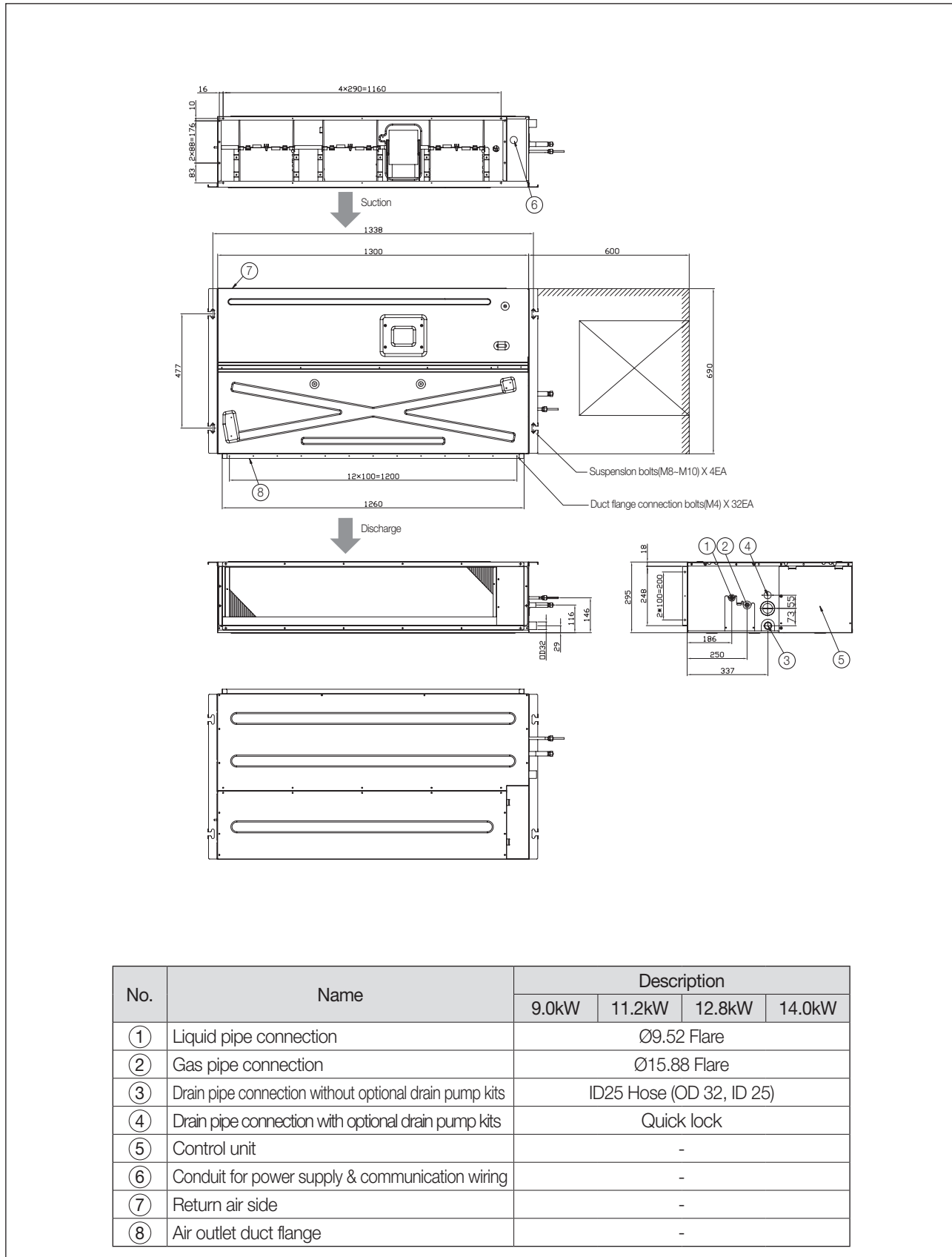

5-4. PCB connector lay-out

1) ND022/028/036/045/056/071LHXEA

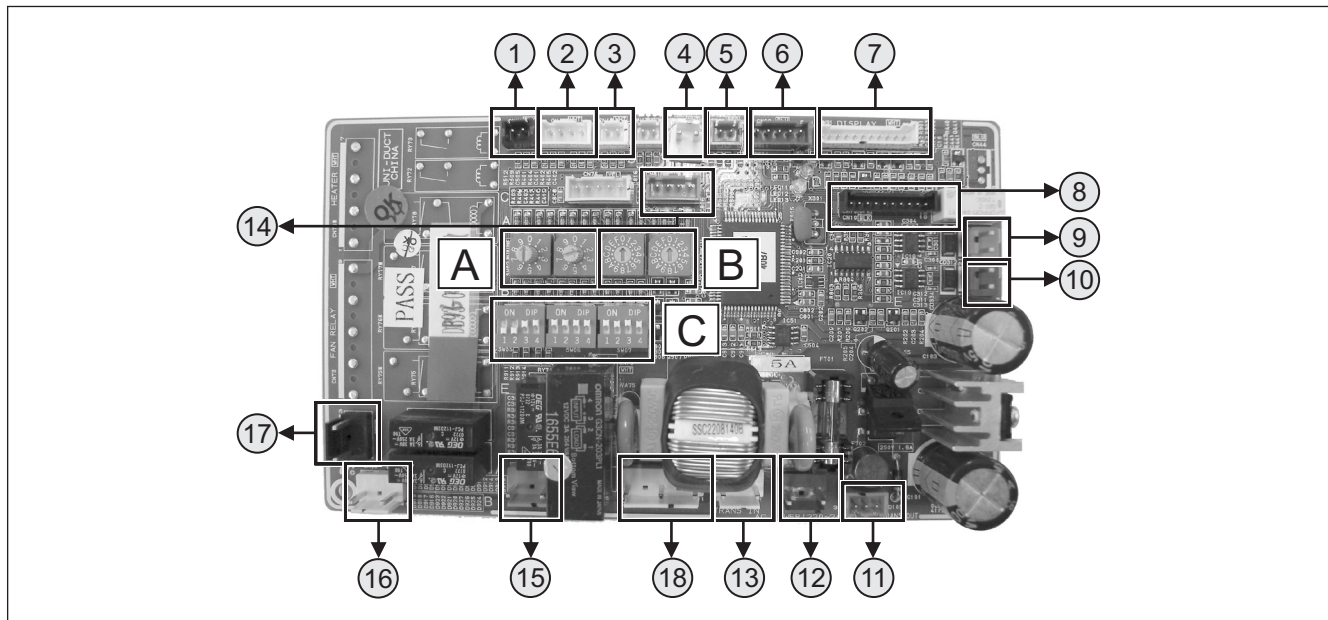

No.	CN #	COLOR	FUNCTION
①	CN51	Black	Float Switch
②	CN41	White	Room Sensor, Eva-In Sensor
③	CN42	White	Eva-Out Sensor
④	CN32	White	DC12V for Wired Remote Controller
⑤	CN83	Red	External Contact Control
⑥	CN62	Blue	EEV
⑦	CN91	White	Display
⑧	CN10	Black	MICOM Download
⑨	CN31	Red	Communication with Outdoor Units (COM1)
⑩	CN33	Blue	Communication with Wired Remote Controller (COM2)
⑪	CN11	Red	Trans-Out (AC 17V)
⑫	CN71	Blue	AC 230V Input
⑬	CN72	White	Trans-In (AC 230V)
⑭	CN81	Red	Error Check, Indoor unit Operation
⑮	CN77	Red	Hot Water Coil
⑯	CN74	Yellow	Drain Pump
⑰	CN75	Black	Ventilator
⑱	CN78	White	Fan Motor

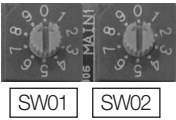
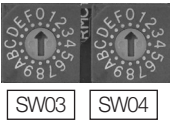
No.	S/W	FUNCTION
A	 SW01 SW02	Main Address (00~63)
B	 SW03 SW04	SW03 Address of Interface Module Channel 0-2 SW04 Group Address (RMC) for Centralized Control 0-F

No.	S/W	FUNCTION	ON	OFF
	K1	-	-	-
	K2	Centralized Controller	Not use	Use
	K3	RPM Up	N/A	N/A
	K4	Optional Drain Pump	Not use	Use
	K5	Heating Thermo-off	+5°C	+2°C
	K6	Filter Signal Display	1,000hrs	2,000hrs
C	K7	Hot Water Coil	Not use	Use
	K8	Electrical Heater	N/A	N/A
	K9	Min. EEV Step at Heating	Fixed 80 step	0 or 80 step
	K10	Priority of Indoor unit Display on Wired Remote Controlle	Slave (Default)	Master
	K11	External Contact Control	Not use	Use
	K12	-	-	-

5 Slim duct

5-4. PCB connector lay-out

2) ND090/112/128/140LHXEA

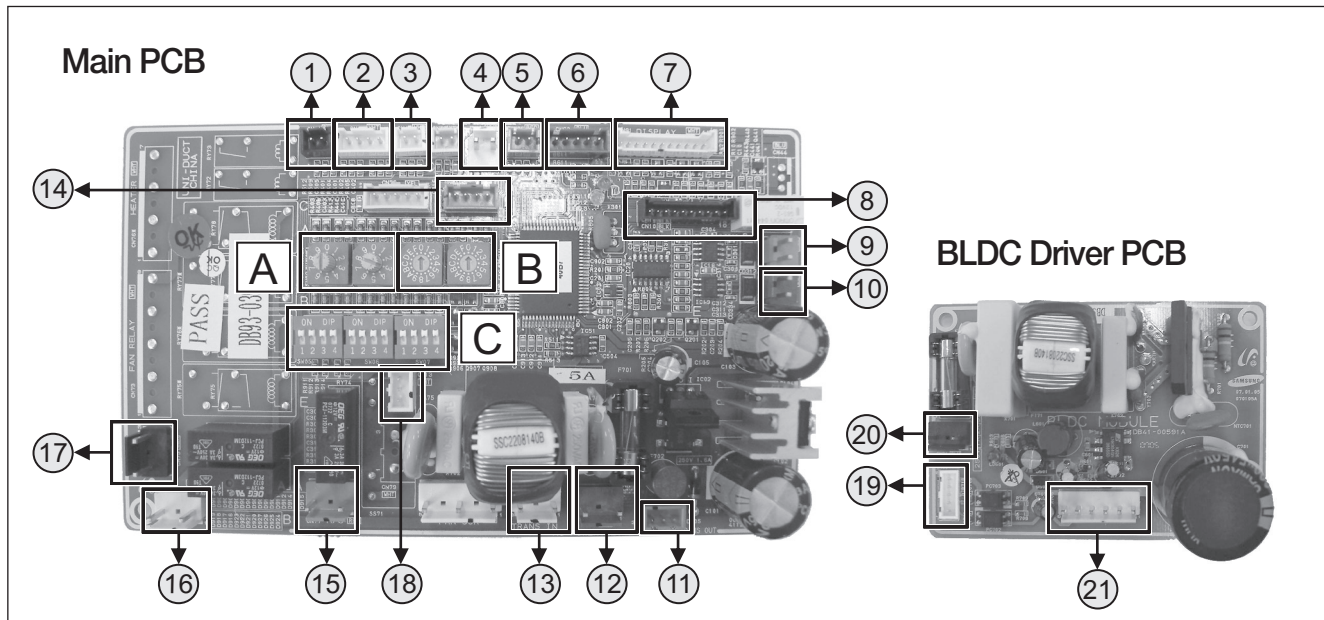

Main PCB			
No.	CN #	COLOR	FUNCTION
①	CN51	Black	Float Switch
②	CN41	White	Room Sensor, Eva-In Sensor
③	CN42	White	Eva-Out Sensor
④	CN32	White	DC12V for Wired Remote Controller
⑤	CN83	Red	External Contact Control
⑥	CN62	Blue	EEV
⑦	CN91	White	Display
⑧	CN10	Black	MICOM Download
⑨	CN31	Red	Communication with Outdoor Units (COM1)
⑩	CN33	Blue	Communication with Wired Remote Controller (COM2)
⑪	CN11	Red	Trans-Out (AC 17V)
⑫	CN71	Blue	AC 208~230V Input
⑬	CN72	White	Trans-In (AC 208~230V)
⑭	CN81	Red	Error Check, Indoor unit Operation
⑮	CN77	Red	Hot Water Coil
⑯	CN74	Yellow	Drain Pump
⑰	CN75	Black	Ventilator
⑱	CN13	White	Main-BLDC Driver PCB Connector

BLDC Driver PCB			
No.	CN #	COLOR	FUNCTION
⑱	CN35	White	Main-BLDC Driver PCB Connector
⑳	CN71	Blue	AC Power
㉑	CN72	White	Fan Motor

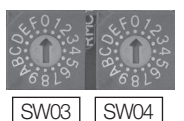
No.	S/W	FUNCTION	
A		Main Address (00~63)	
B		SW03	SW04
		Address of Interface Module Channel 0~2	Group Address (RMC) for Centralized Control 0~F

No.	S/W	FUNCTION	ON	OFF
	K1	-	-	-
	K2	Centralized Controller	Not use	Use
	K3	RPM Up	N/A	N/A
	K4	Optional Drain Pump	Not use	Use
	K5	Heating Thermo-off	+2°C	+5°C
	K6	Filter Signal Display	1,000hrs	2,000hrs
C	K7	Hot Water Coil	Not use	Use
	K8	Electrical Heater	N/A	N/A
	K9	Min. EEV Step at Heating	Fixed 80 step	0 or 80 step
	K10	Priority of Indoor unit Display on Wired Remote Controlle	Slave (Default)	Master
	K11	External Contact Control	Not use	Use
	K12	-	-	-

5-5. Electrical wiring diagram

1) ND022/028/036/045/056/071LHXEA

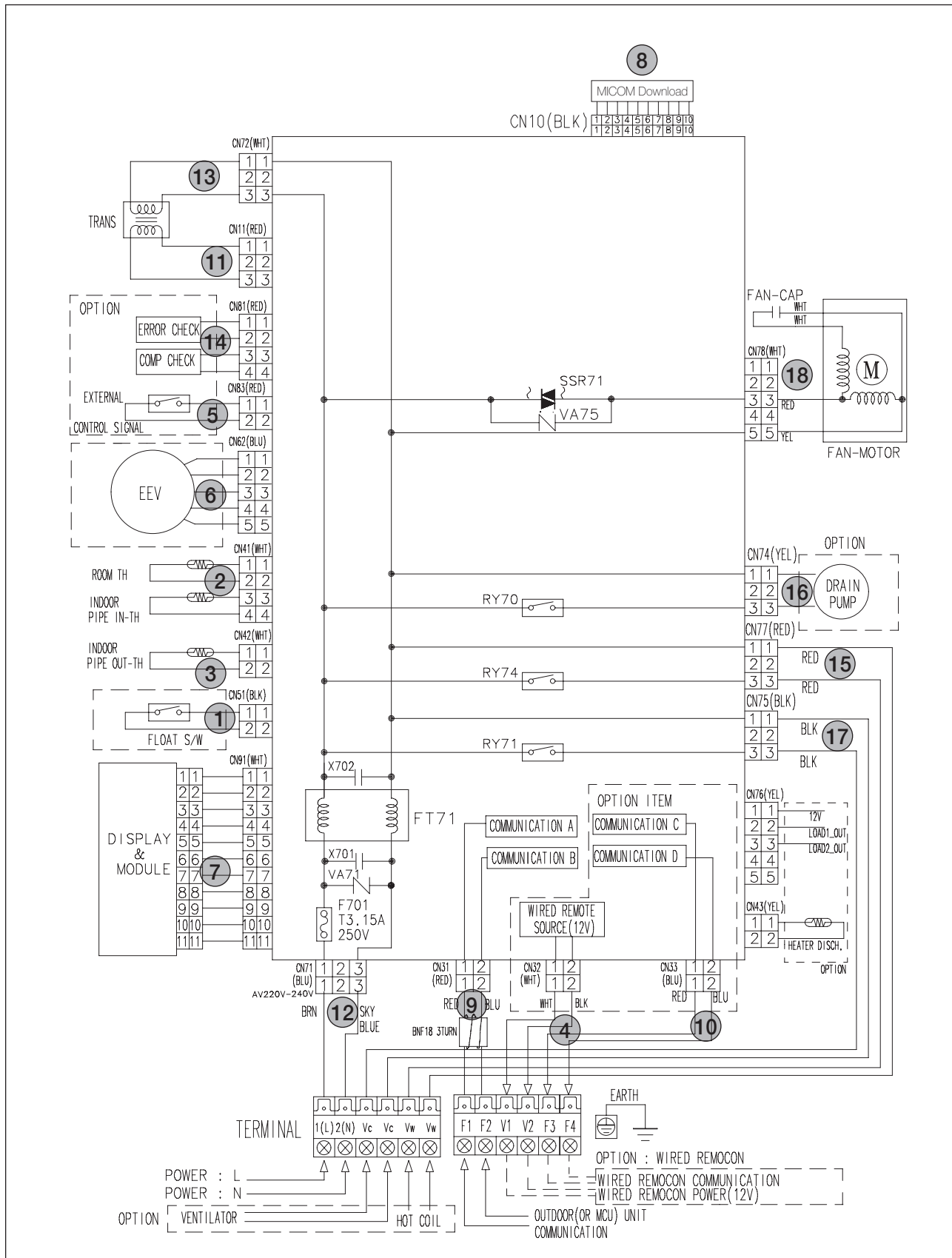

Indoor units

5 Slim duct

5-5. Electrical wiring diagram

2) ND090/112/128/140LHXEA

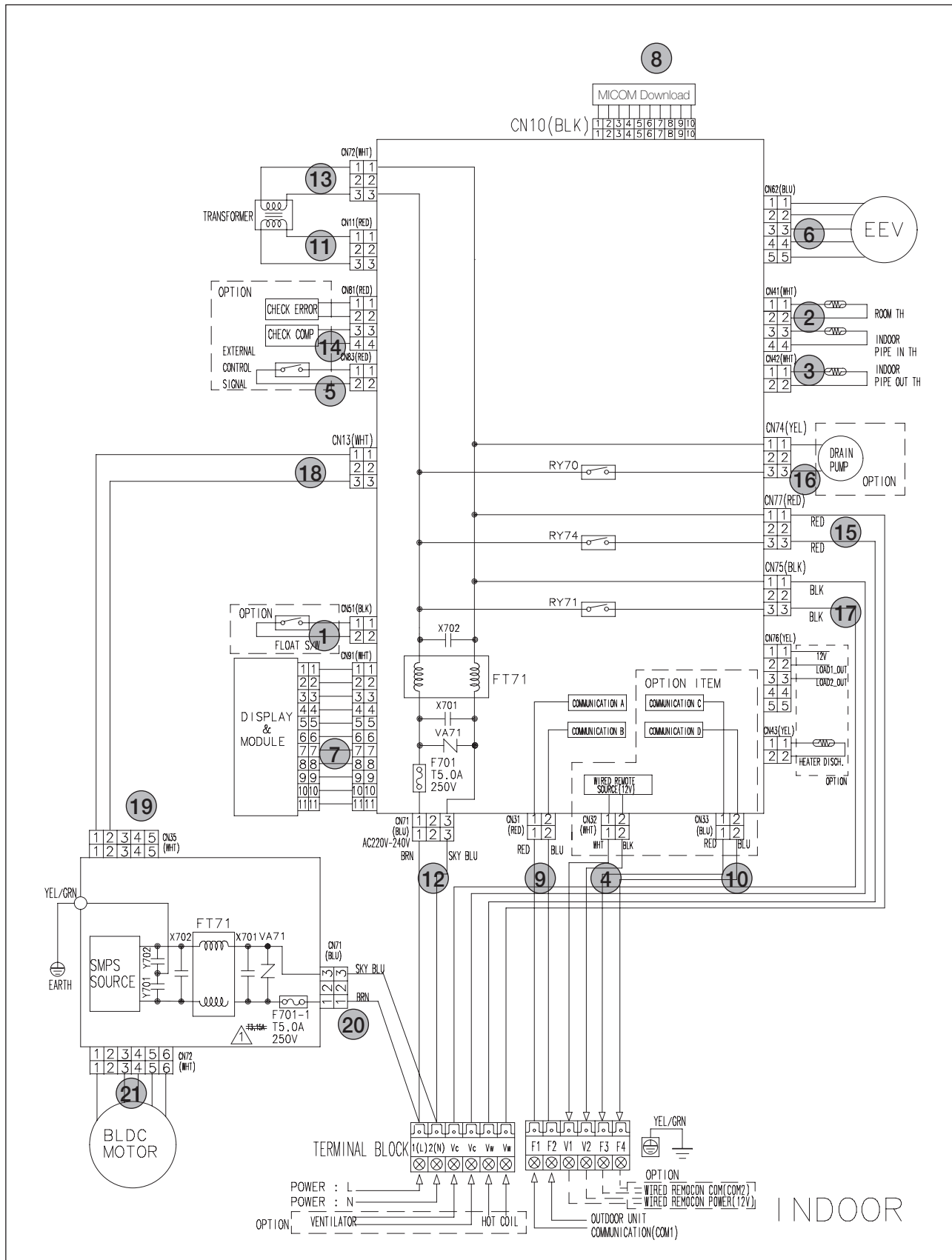

5-6. Sound pressure level

1) Operation sound level

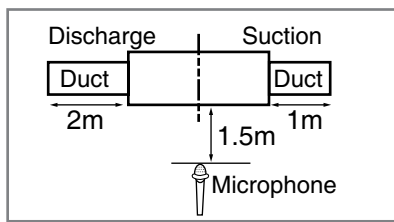

Model	Unit : dB(A)	
	High	Low
ND022LHXEA	31	26
ND028LHXEA	32	27
ND036LHXEA	32	27
ND045LHXEA	33	30
ND056LHXEA	33	30

Model	Unit : dB(A)	
	High	Low
ND071LHXEA	36	32
ND090LHXEA	40	36
ND112LHXEA	40	36
ND128LHXEA	41	38
ND140LHXEA	41	38

Note

- ◆ These operation values were obtained in a dead room. Sound pressure level will vary depending on a range of factors such as the construction of the particular room where the equipment is installed.
- ◆ Operation sound level may differ depending on operation and ambient conditions.

2) NC curves

(1) ND022LHXEA

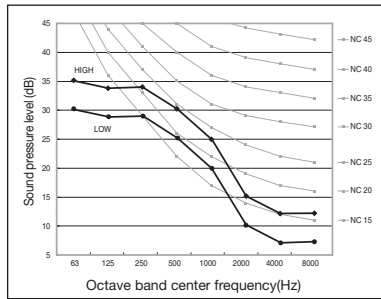

(2) ND028LHXEA

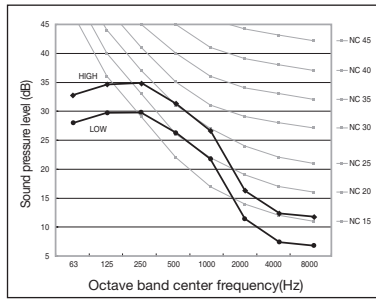

(3) ND036LHXEA

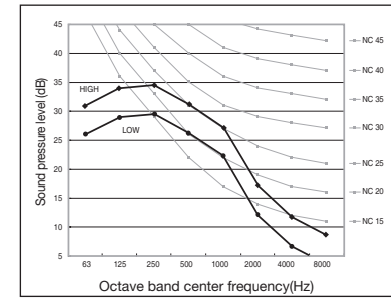

(4) ND045LHXEA

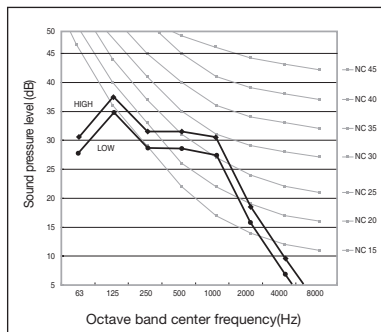

(5) ND056LHXEA

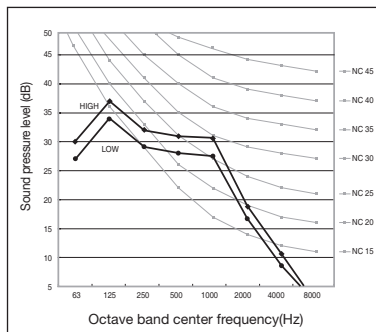

5-6. Sound pressure level

2) NC curves

(6) ND071LHXEA

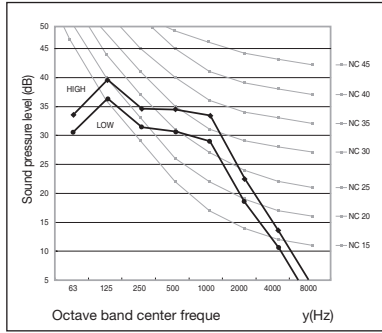

(7) ND090LHXEA

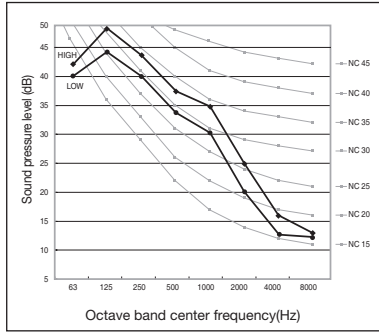

(8) ND112LHXEA

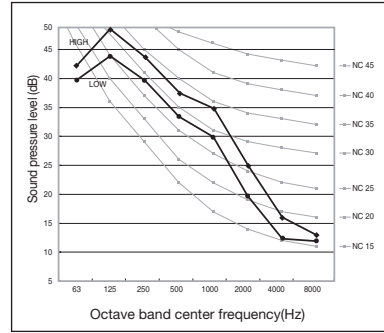

(9) ND128LHXEA

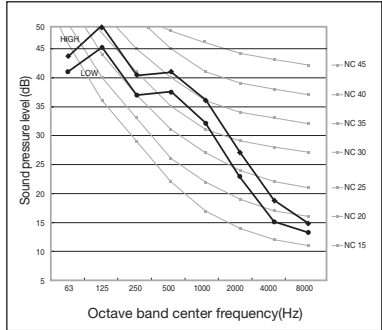

(10) ND140LHXEA

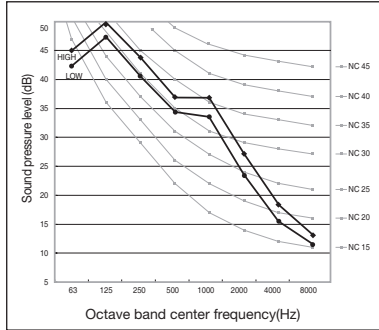

5-7. Recommended operation range

◆ Adjust option code according to the actual installation condition (external static pressure).

(1) ND022LHXEA

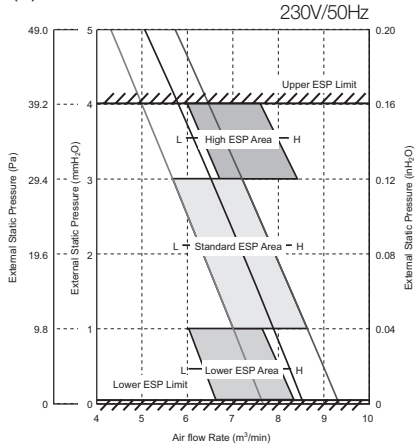

External Static pressure (mmAq)	Option code
0	0152011200B6-200000300000
2	0152011200EA-200000300000
4	01520112021E-200000300000

(2) ND028LHXEA

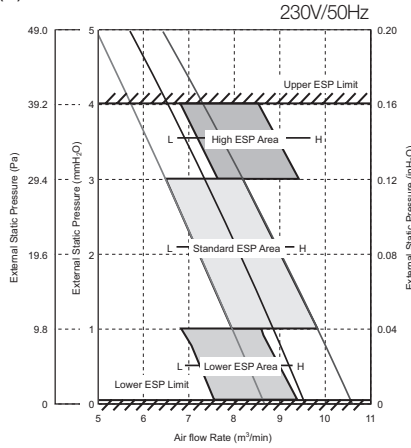

External Static pressure (mmAq)	Option code
0	0152011400E8-200000300000
2	01520114022C-200000300000
4	015201140362-200000300000

(3) ND036LHXEA

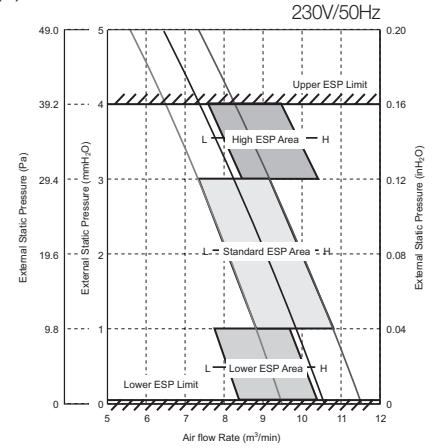

External Static pressure (mmAq)	Option code
0	01520116024C-200000300000
2	0152011603A0-200000300000
4	015203160174-200000300000

(4) ND045LHXEA

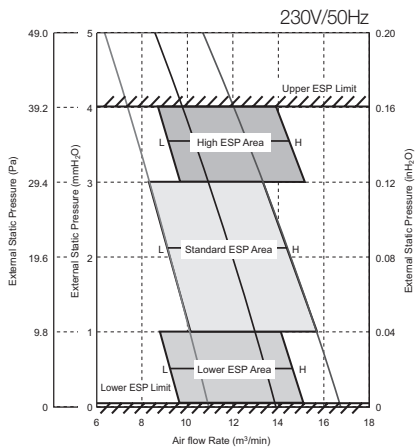

External Static pressure (mmAq)	Option code
0	0152211703F3-200000300000
2	015223170135-200000300000
4	0152231701D9-200000300000

(5) ND056LHXEA

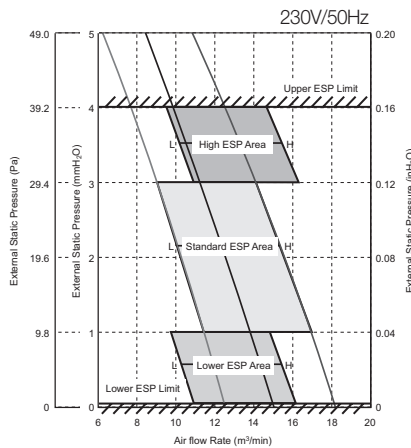

External Static pressure (mmAq)	Option code
0	015223190148-200000300000
2	0152231901BA-200000300000
4	0152231903CE-200000300000

☑ Note

- ◆ ESP = External Static Pressure
- ◆ The graphs display the available external static pressure range of installed indoor units. Therefore, they do not reflect the actual change of external static pressure and airflow rate according to adjusted airflow (High-Mid-Low) of installed indoor units.

Indoor units

5 Slim duct

5-7. Recommended operation range

◆ Adjust option code according to the actual installation condition (external static pressure).

(6) ND071LHXEA

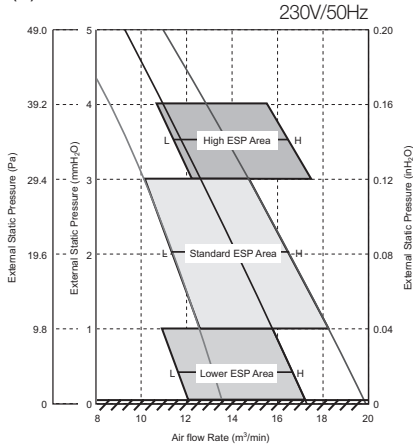

External Static pressure (mmAq)	Option code
0	0152231C01BB-200000300000
2	0152231C039E-200000300000
4	0152241C02F4-200000300000

(7) ND090LHXEA

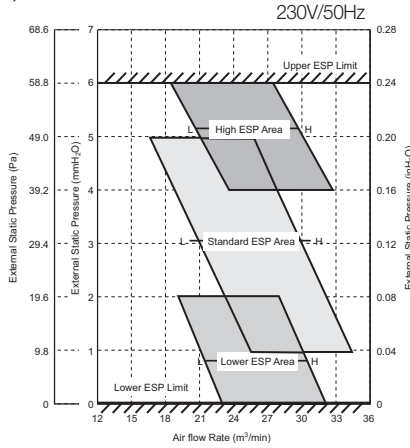

External Static pressure (mmAq)	Option code
0	0152131E016C-200000300000
3	0152141E00D4-200000300000
6	0152141E022A-200000300000

(8) ND112LHXEA

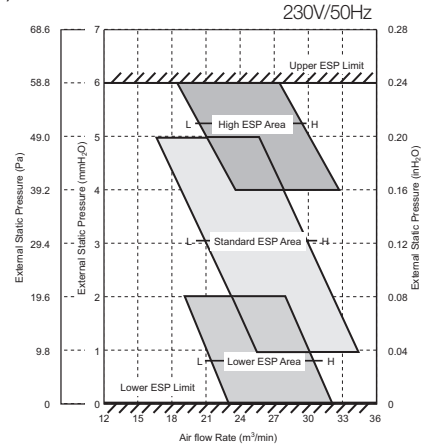

External Static pressure (mmAq)	Option code
0	015A1310016C-200000300000
3	015A141000D4-200000300000
6	015A1410022A-200000300000

(9) ND128LHXEA

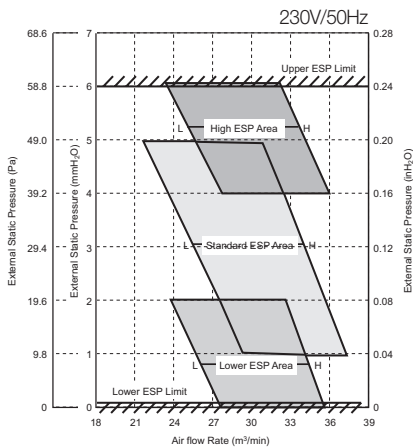

External Static pressure (mmAq)	Option code
0	015A141200F5-200000300000
3	015A1412024B-200000300000
6	015A1412028F-200000300000

(10) ND140LHXEA

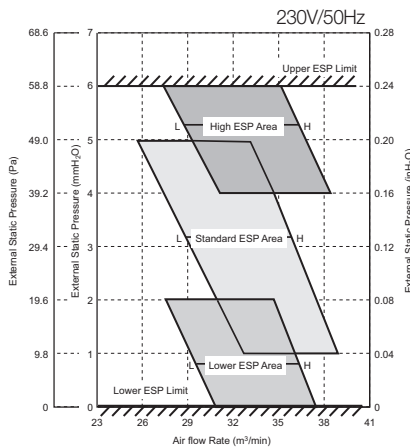

External Static pressure (mmAq)	Option code
0	015A1413023A-200000300000
3	015A1413027F-200000300000
6	015A141303C3-200000300000

Note

- ◆ ESP = External Static Pressure
- ◆ The graphs display the available external static pressure range of installed indoor units. Therefore, they do not reflect the actual change of external static pressure and airflow rate according to adjusted airflow (High-Mid-Low) of installed indoor units.



6 MSP(Middle static pressure) duct (AVXDUH***E*)

6-1. Specifications.....	78
6-2. Capacity tables	79
6-3. Dimensional drawing.....	82
6-4. PCB connector lay-out.....	86
6-5. Electrical wiring diagram	88
6-6. Sound pressure level	90
6-7. Recommended operation range	91

Optional Accessories

Individual Controllers



Drain Pump



MDP-M07SSGU1
MDP-M07SSGU2
MDP-M07SSGU3

6-1. Specifications

1) Technical specifications

Model			AVXDUH056E*	AVXDUH071E*	AVXDUH090E*	AVXDUH112E*	AVXDUH128E*	AVXDUH140E*	
Power Supply			Ø, #, V, Hz	1, 2, 220~240, 50	1, 2, 220~240, 50	1, 2, 220~240, 50	1, 2, 220~240, 50	1, 2, 220~240, 50	
Mode*1)			-	HP / HR	HP / HR	HP / HR	HP / HR	HP / HR	
Capacity (Nominal)	Cooling *2)	kW	5.6	7.1	9.0	11.2	12.8	14.0	
		Btu/h	19,100	24,200	30,700	38,200	43,700	47,800	
	Heating *3)	kW	6.3	8.0	10.0	12.5	13.8	16.0	
		Btu/h	21,500	27,300	34,100	42,700	47,100	54,600	
Power	Power Input (Nominal)	Cooling *2)	W	130	190	240	260	370	410
		Heating *3)	W	130	190	240	260	370	410
	Current Input (Nominal)	Cooling *2)	A	1.10	1.25	1.30	1.17	1.67	1.86
		Heating *3)	A	1.10	1.25	1.30	1.17	1.67	1.86
Fan	Motor	Type	-	Sirocco Fan / AC	Sirocco Fan / AC	Sirocco Fan / AC	Sirocco Fan / AC	Sirocco Fan / AC	Sirocco Fan / AC
		Output	W	124	124	130	130	218	218
		Number of unit	EA	1	1	1	1	1	1
	Air Flow Rate	H/M/L (UL)	CMM	14.5 / 13 / 11.5	18.5 / 17 / 15.5	19.5 / 18 / 16.5	27 / 25 / 23	32 / 30 / 28	37 / 34 / 31
			CFM	510 / 460 / 410	650 / 600 / 550	690 / 640 / 580	950 / 880 / 810	1130 / 1060 / 990	1310 / 1200 / 1090
	External Pressure	Min / Std / Max	mmAq	0 / 4 / 8	0 / 4 / 8	4 / 6 / 8	6 / 8 / 12	6 / 8 / 14	6 / 8 / 14
			Pa	0 / 39.2 / 78.5	0 / 39.2 / 78.5	39.2 / 58.8 / 78.5	58.8 / 78.5 / 117.7	58.8 / 78.5 / 137.7	58.8 / 78.5 / 137.7
			WG			0.157 / 0.236 / 0.315			
Option Code			-	015221-1A03C5-200000-300000	015223-1C0179-200000-300000	015223-1E0329-200000-300000	012A24-1002BB-200000-300000	012A24-1200B0-200000-300000	012A24-130224-200000-300000
Piping Connections	Liquid Pipe	Ø, mm	6.35	9.52	9.52	9.52	9.52	9.52	
		Ø, inch	1/4	3/8	3/8	3/8	3/8	3/8	
	Gas Pipe	Ø, mm	12.7	15.88	15.88	15.88	15.88	15.88	
		Ø, inch	1/2	5/8	5/8	5/8	5/8	5/8	
	Drain Pipe	Ø, mm	ID25 Hose (OD 32, ID 25)	ID25 Hose (OD 32, ID 25)	ID25 Hose (OD 32, ID 25)	ID25 Hose (OD 32, ID 25)	ID25 Hose (OD 32, ID 25)	ID25 Hose (OD 32, ID 25)	
Field Wiring	Power Source Wire	Below 20m / over 20m	mm ²	1.5 / 2.5	1.5 / 2.5	1.5 / 2.5	1.5 / 2.5	1.5 / 2.5	
	Transmission Cable		mm ²	0.75 / 1.5	0.75 / 1.5	0.75 / 1.5	0.75 / 1.5	0.75 / 1.5	
Refrigerant	Type	-	R410A	R410A	R410A	R410A	R410A	R410A	
	Control Method	-	EEV	EEV	EEV	EEV	EEV	EEV	
Sound	Sound Pressure	High / Low *4)	dBA	37 / 33	39 / 35	39 / 35	39 / 35	39 / 35	43 / 38
Dimensions	Net Weight		kg	31	31	35	39	52	52
	Shipping Weight		kg	36	36	41	46	60	60
	Net Dimensions (W×H×D)		mm	900 x 260 x 480	900 x 260 x 480	1,150 x 260 x 480	1,150 x 320 x 480	1,200 x 360 x 650	1,200 x 360 x 650
	Shipping Dimensions (W×H×D)		mm	1,146 x 345 x 584	1,146 x 345 x 584	1,390 x 345 x 584	1,390 x 420 x 584	1,447 x 425 x 769	1,447 x 425 x 769
	Panel model		-	-	-	-	-	-	-
Panel Size	Panel Net Weight		kg	-	-	-	-	-	-
	Shipping Weight		kg	-	-	-	-	-	-
	Net Dimensions (W×H×D)		mm	-	-	-	-	-	-
	Shipping Dimensions (W×H×D)		mm	-	-	-	-	-	-
	Additional Accessories	Drain pump	Drain pump	- / Model	Optional / MDP-E075SGU3	Optional / MDP-E075SGU3	Optional / MDP-E075SGU1	Optional / MDP-E075SGU1	Optional / MDP-E075SGU2
Max. lifting Height / Displacement			mm/liter/h	750 / 24	750 / 24	750 / 24	750 / 24	750 / 24	750 / 24
Air Filter		-	Long life filter	Long life filter	Long life filter	Long life filter	Long life filter	Long life filter	

* Specifications may be subject to change without prior notice for product improvement.

*1) Mode

- HP : Heat Pump, HR : Heat Recovery

*2) Nominal cooling capacities are based on;

- Indoor temperature : 27°C DB, 19°C WB

- Outdoor temperature : 35°C DB, 24°C WB, Equivalent refrigerant piping : 7.5m, Level differences : 0m

*3) Nominal heating capacities are based on;

- Indoor temperature : 20°C DB, 15°C WB

- Outdoor temperature : 7°C DB, 6°C WB, Equivalent refrigerant piping : 7.5m, Level differences : 0m

*4) Sound pressure was acquired in a dead room. Thus actual noise level may be different depending on the installation conditions.

6-2. Capacity tables

1) Cooling

TC : Total Capacity(kW), SHC : Sensible Heat Capacity(kW)

Model	Outdoor temperature (°C, DB)	Indoor temperature (°C, WB)													
		20 (°C, DB) 14 (°C, WB)		23 (°C, DB) 16 (°C, WB)		26 (°C, DB) 18 (°C, WB)		27 (°C, DB) 19 (°C, WB)		28 (°C, DB) 20 (°C, WB)		30 (°C, DB) 22 (°C, WB)		32 (°C, DB) 24 (°C, WB)	
		TC	SHC	TC	SHC	TC	SHC	TC	SHC	TC	SHC	TC	SHC	TC	SHC
056	10	3.9	3.4	4.6	3.9	5.3	4.1	5.6	4.3	5.8	4.3	6.3	4.4	6.7	4.2
	12	3.9	3.4	4.6	3.9	5.3	4.1	5.6	4.3	5.8	4.3	6.3	4.4	6.7	4.2
	14	3.9	3.4	4.6	3.9	5.3	4.1	5.6	4.3	5.8	4.3	6.2	4.3	6.7	4.2
	16	3.9	3.4	4.6	3.9	5.3	4.1	5.6	4.3	5.8	4.3	6.2	4.3	6.6	4.1
	18	3.9	3.4	4.6	3.9	5.3	4.1	5.6	4.3	5.8	4.3	6.2	4.3	6.6	4.1
	20	3.9	3.4	4.6	3.9	5.3	4.1	5.6	4.3	5.8	4.3	6.2	4.3	6.6	4.1
	21	3.9	3.4	4.6	3.9	5.3	4.1	5.6	4.3	5.8	4.3	6.2	4.3	6.6	4.1
	23	3.9	3.4	4.6	3.9	5.3	4.1	5.6	4.3	5.8	4.3	6.2	4.3	6.6	4.1
	25	3.9	3.4	4.6	3.9	5.3	4.1	5.6	4.3	5.8	4.3	6.2	4.3	6.6	4.1
	27	3.9	3.4	4.6	3.9	5.3	4.1	5.6	4.3	5.8	4.3	6.2	4.3	6.6	4.1
	29	3.9	3.4	4.6	3.9	5.3	4.1	5.6	4.3	5.8	4.3	6.2	4.3	6.6	4.1
	31	3.9	3.4	4.6	3.9	5.3	4.1	5.6	4.3	5.8	4.3	6.2	4.3	6.6	4.1
	33	3.9	3.4	4.6	3.9	5.3	4.1	5.6	4.3	5.8	4.3	6.2	4.3	6.6	4.1
	35	3.9	3.4	4.6	3.9	5.3	4.1	5.6	4.3	5.8	4.3	6.2	4.3	6.6	4.1
	37	3.9	3.4	4.6	3.9	5.3	4.1	5.6	4.3	5.8	4.3	6.1	4.2	6.5	4.0
	39	3.9	3.4	4.6	3.9	5.3	4.1	5.6	4.3	5.8	4.3	6.1	4.2	6.4	3.9
42	3.9	3.4	4.6	3.9	5.3	4.1	5.4	4.2	5.6	4.2	5.8	4.1	6.0	3.7	
44	3.9	3.4	4.6	3.9	5.0	4.0	5.3	4.1	5.4	4.1	5.5	4.0	5.6	3.5	
071	10	4.9	4.3	5.8	5.0	6.7	5.2	7.1	5.4	7.4	5.6	8.0	5.7	8.5	5.4
	12	4.9	4.3	5.8	5.0	6.7	5.2	7.1	5.4	7.4	5.6	7.9	5.6	8.5	5.4
	14	4.9	4.3	5.8	5.0	6.7	5.2	7.1	5.4	7.4	5.6	7.9	5.6	8.5	5.4
	16	4.9	4.3	5.8	5.0	6.7	5.2	7.1	5.4	7.4	5.6	7.9	5.6	8.4	5.3
	18	4.9	4.3	5.8	5.0	6.7	5.2	7.1	5.4	7.4	5.6	7.9	5.6	8.4	5.3
	20	4.9	4.3	5.8	5.0	6.7	5.2	7.1	5.4	7.4	5.6	7.9	5.6	8.4	5.3
	21	4.9	4.3	5.8	5.0	6.7	5.2	7.1	5.4	7.4	5.6	7.9	5.6	8.4	5.3
	23	4.9	4.3	5.8	5.0	6.7	5.2	7.1	5.4	7.4	5.6	7.9	5.6	8.4	5.3
	25	4.9	4.3	5.8	5.0	6.7	5.2	7.1	5.4	7.4	5.6	7.9	5.6	8.4	5.3
	27	4.9	4.3	5.8	5.0	6.7	5.2	7.1	5.4	7.4	5.6	7.9	5.6	8.4	5.3
	29	4.9	4.3	5.8	5.0	6.7	5.2	7.1	5.4	7.4	5.6	7.9	5.6	8.4	5.3
	31	4.9	4.3	5.8	5.0	6.7	5.2	7.1	5.4	7.4	5.6	7.9	5.6	8.4	5.3
	33	4.9	4.3	5.8	5.0	6.7	5.2	7.1	5.4	7.4	5.6	7.9	5.6	8.4	5.3
	35	4.9	4.3	5.8	5.0	6.7	5.2	7.1	5.4	7.4	5.6	7.9	5.6	8.4	5.3
	37	4.9	4.3	5.8	5.0	6.7	5.2	7.1	5.4	7.3	5.5	7.8	5.5	8.2	5.2
	39	4.9	4.3	5.8	5.0	6.7	5.2	7.1	5.4	7.3	5.5	7.7	5.4	8.1	5.1
42	4.9	4.3	5.8	5.0	6.7	5.2	6.9	5.3	7.0	5.4	7.3	5.3	7.6	4.9	
44	4.9	4.3	5.8	5.0	6.3	5.0	6.7	5.2	6.8	5.3	7.0	5.2	7.1	4.7	
090	10	6.2	5.5	7.3	6.3	8.4	6.7	9.0	6.9	9.4	7.1	10.1	7.1	10.8	7.1
	12	6.2	5.5	7.3	6.3	8.4	6.7	9.0	6.9	9.4	7.1	10.1	7.1	10.8	7.1
	14	6.2	5.5	7.3	6.3	8.4	6.7	9.0	6.9	9.3	7.0	10.0	7.0	10.7	6.9
	16	6.2	5.5	7.3	6.3	8.4	6.7	9.0	6.9	9.3	7.0	10.0	7.0	10.7	6.9
	18	6.2	5.5	7.3	6.3	8.4	6.7	9.0	6.9	9.3	7.0	10.0	7.0	10.6	6.8
	20	6.2	5.5	7.3	6.3	8.4	6.7	9.0	6.9	9.3	7.0	10.0	7.0	10.6	6.8
	21	6.2	5.5	7.3	6.3	8.4	6.7	9.0	6.9	9.3	7.0	10.0	7.0	10.6	6.8
	23	6.2	5.5	7.3	6.3	8.4	6.7	9.0	6.9	9.3	7.0	10.0	7.0	10.6	6.8
	25	6.2	5.5	7.3	6.3	8.4	6.7	9.0	6.9	9.3	7.0	10.0	7.0	10.6	6.8
	27	6.2	5.5	7.3	6.3	8.4	6.7	9.0	6.9	9.3	7.0	10.0	7.0	10.6	6.8
	29	6.2	5.5	7.3	6.3	8.4	6.7	9.0	6.9	9.3	7.0	10.0	7.0	10.6	6.8
	31	6.2	5.5	7.3	6.3	8.4	6.7	9.0	6.9	9.3	7.0	10.0	7.0	10.6	6.8
	33	6.2	5.5	7.3	6.3	8.4	6.7	9.0	6.9	9.3	7.0	10.0	7.0	10.6	6.8
	35	6.2	5.5	7.3	6.3	8.4	6.7	9.0	6.9	9.3	7.0	10.0	7.0	10.6	6.8
	37	6.2	5.5	7.3	6.3	8.4	6.7	9.0	6.9	9.3	7.0	9.9	6.9	10.4	6.7
	39	6.2	5.5	7.3	6.3	8.4	6.7	9.0	6.9	9.2	6.9	9.7	6.8	10.2	6.6
42	6.2	5.5	7.3	6.3	8.4	6.7	8.7	6.7	8.9	6.8	9.3	6.6	9.6	6.4	
44	6.2	5.5	7.3	6.3	8.0	6.5	8.6	6.6	8.6	6.7	8.8	6.4	9.0	6.2	
112	10	7.7	6.5	9.1	7.5	10.5	8.0	11.2	8.3	11.6	8.5	12.5	8.4	13.4	8.3
	12	7.7	6.5	9.1	7.5	10.5	8.0	11.2	8.3	11.6	8.5	12.5	8.4	13.4	8.3
	14	7.7	6.5	9.1	7.5	10.5	8.0	11.2	8.3	11.6	8.5	12.5	8.4	13.3	8.2
	16	7.7	6.5	9.1	7.5	10.5	8.0	11.2	8.3	11.6	8.5	12.5	8.4	13.3	8.2
	18	7.7	6.5	9.1	7.5	10.5	8.0	11.2	8.3	11.6	8.5	12.4	8.3	13.2	8.2
	20	7.7	6.5	9.1	7.5	10.5	8.0	11.2	8.3	11.6	8.5	12.4	8.3	13.2	8.1
	21	7.7	6.5	9.1	7.5	10.5	8.0	11.2	8.3	11.6	8.5	12.4	8.3	13.2	8.1
	23	7.7	6.5	9.1	7.5	10.5	8.0	11.2	8.3	11.6	8.5	12.4	8.3	13.2	8.1
	25	7.7	6.5	9.1	7.5	10.5	8.0	11.2	8.3	11.6	8.5	12.4	8.4	13.2	8.1
	27	7.7	6.5	9.1	7.5	10.5	8.0	11.2	8.3	11.6	8.5	12.4	8.3	13.2	8.1
	29	7.7	6.5	9.1	7.5	10.5	8.0	11.2	8.3	11.6	8.5	12.4	8.3	13.2	8.1
	31	7.7	6.5	9.1	7.5	10.5	8.0	11.2	8.3	11.6	8.5	12.4	8.5	13.2	8.1
	33	7.7	6.5	9.1	7.5	10.5	8.0	11.2	8.3	11.6	8.5	12.4	8.5	13.2	8.1
	35	7.7	6.5	9.1	7.5	10.5	8.0	11.2	8.3	11.6	8.5	12.4	8.4	13.2	8.1
	37	7.7	6.5	9.1	7.5	10.5	8.0	11.2	8.3	11.6	8.5	12.3	8.5	13.0	8.0
	39	7.7	6.5	9.1	7.5	10.5	8.0	11.2	8.3	11.5	8.5	12.1	8.4	12.7	7.9
42	7.7	6.5	9.1	7.5	10.5	8.0	10.9	8.1	11.1	8.3	11.6	8.1	12.0	7.7	
44	7.7	6.5	9.1	7.5	10.5	8.0	10.9	8.1	11.1	8.3	11.6	8.1	12.0	7.7	

Indoor units

6

MSP(Middle static pressure) duct

6-2. Capacity tables

1) Cooling

TC : Total Capacity(kW), SHC : Sensible Heat Capacity(kW)

Model	Outdoor temperature (°C, DB)	Indoor temperature (°C, WB)													
		20 (°C, DB) 14 (°C, WB)		23 (°C, DB) 16 (°C, WB)		26 (°C, DB) 18 (°C, WB)		27 (°C, DB) 19 (°C, WB)		28 (°C, DB) 20 (°C, WB)		30 (°C, DB) 22 (°C, WB)		32 (°C, DB) 24 (°C, WB)	
		TC	SHC	TC	SHC	TC	SHC	TC	SHC	TC	SHC	TC	SHC	TC	SHC
128	10	10.4	7.6	10.4	8.7	12.0	9.3	12.8	9.7	13.3	9.9	14.3	6.3	15.4	9.8
	12	10.4	7.6	10.4	8.7	12.0	9.3	12.8	9.7	13.3	9.9	14.3	6.3	15.3	9.8
	14	10.4	7.6	10.4	8.7	12.0	9.3	12.8	9.7	13.3	9.9	14.3	6.2	15.3	9.7
	16	10.4	9.0	10.4	8.7	12.0	9.3	12.8	9.7	13.3	9.9	14.2	6.2	15.2	9.7
	18	10.4	9.0	10.4	8.7	12.0	9.3	12.8	9.7	13.3	9.9	14.2	6.2	15.1	9.7
	20	10.4	9.0	10.4	8.7	12.0	9.3	12.8	9.7	13.3	9.9	14.2	6.2	15.1	9.7
	21	10.4	9.0	10.4	8.7	12.0	9.3	12.8	9.7	13.3	9.9	14.2	6.2	15.1	9.7
	23	10.4	9.0	10.4	8.7	12.0	9.3	12.8	9.7	13.3	9.9	14.2	6.2	15.1	9.7
	25	10.4	9.0	10.4	8.7	12.0	9.3	12.8	9.7	13.3	9.9	14.2	6.2	15.1	9.7
	27	10.4	9.0	10.4	8.7	12.0	9.3	12.8	9.7	13.3	9.9	14.2	6.2	15.1	9.7
	29	10.4	9.0	10.4	8.7	12.0	9.3	12.8	9.7	13.3	9.9	14.2	6.2	15.1	9.7
	31	10.4	9.0	10.4	8.7	12.0	9.3	12.8	9.7	13.3	9.9	14.2	6.2	15.1	9.7
	33	10.4	9.0	10.4	8.7	12.0	9.3	12.8	9.7	13.3	9.9	14.2	6.2	15.1	9.7
	35	10.4	9.0	10.4	8.7	12.0	9.3	12.8	9.7	13.3	9.8	14.2	6.2	15.1	9.7
	37	10.4	9.0	10.4	8.7	12.0	9.3	12.8	9.7	13.2	9.9	14.0	6.1	14.9	9.6
	39	10.4	9.0	10.4	8.7	12.0	9.3	12.8	9.7	13.1	9.9	13.8	6.1	14.5	9.6
42	10.4	9.0	10.4	8.7	12.0	9.3	12.4	9.4	12.7	9.6	13.2	5.8	13.7	9.1	
44	10.4	9.0	10.4	8.7	12.0	9.3	12.4	9.4	12.7	9.6	13.2	5.8	13.7	9.1	
140	10	9.7	8.6	11.4	9.6	13.1	10.4	14.0	10.8	14.6	11.0	8.0	15.7	16.8	11.2
	12	9.7	8.6	11.4	9.6	13.1	10.4	14.0	10.8	14.5	11.0	7.9	15.6	16.7	11.2
	14	9.7	8.6	11.4	9.6	13.1	10.4	14.0	10.8	14.5	11.0	7.9	15.6	16.7	11.1
	16	9.7	8.6	11.4	9.6	13.1	10.4	14.0	10.8	14.5	11.0	7.9	15.6	16.6	11.1
	18	9.7	8.6	11.4	9.6	13.1	10.4	14.0	10.8	14.5	11.0	7.9	15.5	16.6	11.0
	20	9.7	8.6	11.4	9.6	13.1	10.4	14.0	10.8	14.5	11.0	7.9	15.5	16.5	11.0
	21	9.7	8.6	11.4	9.6	13.1	10.4	14.0	10.8	14.5	11.0	7.9	15.5	16.5	11.0
	23	9.7	8.6	11.4	9.6	13.1	10.4	14.0	10.8	14.5	11.0	7.9	15.5	16.5	11.0
	25	9.7	8.6	11.4	9.6	13.1	10.4	14.0	10.8	14.5	11.0	7.9	15.5	16.5	11.0
	27	9.7	8.6	11.4	9.6	13.1	10.4	14.0	10.8	14.5	11.0	7.9	15.5	16.5	11.0
	29	9.7	8.6	11.4	9.6	13.1	10.4	14.0	10.8	14.5	11.0	7.9	15.5	16.5	11.0
	31	9.7	8.6	11.4	9.6	13.1	10.4	14.0	10.8	14.5	11.0	7.9	15.5	16.5	11.0
	33	9.7	8.6	11.4	9.6	13.1	10.4	14.0	10.8	14.5	11.0	7.9	15.5	16.5	11.0
	35	9.7	8.6	11.4	9.6	13.1	10.4	14.0	10.8	14.5	10.9	7.9	15.5	16.5	11.0
	37	9.7	8.6	11.4	9.6	13.1	10.4	14.0	10.8	14.5	11.0	7.8	15.4	16.3	11.0
	39	9.7	8.6	11.4	9.6	13.1	10.4	14.0	10.8	14.4	10.9	7.7	15.1	15.9	10.8
42	9.7	8.6	11.4	9.6	13.1	10.4	13.6	10.5	13.9	10.6	7.3	14.4	15.0	10.2	
44	9.7	8.6	11.4	9.6	13.1	10.4	13.6	10.5	13.9	10.6	7.3	14.4	15.0	10.2	

2) Heating

TC : Total Capacity(kW)

Model	Outdoor temperature (°C)		Indoor temperature (°C, DB)				
			16.0	18.0	20.0	22.0	24.0
			TC	TC	TC	TC	TC
056	DB	WB	kW	kW	kW	kW	kW
	-20	-21	3.9	3.8	3.8	3.7	3.7
	-17	-18	4.0	4.0	3.9	3.8	3.8
	-15	-16	4.2	4.1	4.0	3.9	3.8
	-12	-13	4.4	4.3	4.2	4.2	4.1
	-10	-11	4.6	4.6	4.5	4.4	4.4
	-7	-8	4.9	4.8	4.8	4.7	4.5
	-5	-6	5.2	5.1	5.0	4.9	4.7
	-3	-4	5.4	5.3	5.3	5.1	4.9
	0	-1	5.7	5.6	5.5	5.3	5.0
	3	2.2	5.9	5.9	5.8	5.6	5.3
	5	4.1	6.2	6.1	6.0	5.7	5.3
	7	6	6.5	6.4	6.3	5.8	5.3
	9	7.9	6.7	6.5	6.3	5.8	5.3
	11	9.8	6.9	6.6	6.3	5.8	5.3
	13	12	7.1	6.7	6.3	5.8	5.3
15	14	7.3	6.8	6.3	5.8	5.3	
071	-20	-21	4.9	4.9	4.8	4.7	4.7
	-17	-18	5.1	5.0	4.9	4.8	4.8
	-15	-16	5.3	5.2	5.1	4.9	4.8
	-12	-13	5.6	5.5	5.4	5.3	5.2
	-10	-11	5.9	5.8	5.7	5.6	5.6
	-7	-8	6.2	6.1	6.0	5.9	5.8
	-5	-6	6.5	6.5	6.4	6.2	6.0
	-3	-4	6.9	6.8	6.7	6.4	6.2
	0	-1	7.2	7.1	7.0	6.7	6.4
	3	2.2	7.6	7.5	7.3	7.1	6.8
	5	4.1	7.9	7.8	7.7	7.2	6.8
	7	6	8.2	8.1	8.0	7.4	6.8
	9	7.9	8.5	8.2	8.0	7.4	6.8
	11	9.8	8.7	8.4	8.0	7.4	6.8
	13	12	9.0	8.5	8.0	7.4	6.8
	15	14	9.2	8.6	8.0	7.4	6.8

2) Heating

TC : Total Capacity(kW)

Model	Outdoor temperature (°C)		Indoor temperature (°C, DB)				
			16.0	18.0	20.0	22.0	24.0
	DB	WB	TC kW	TC kW	TC kW	TC kW	TC kW
090	-20	-21	6.0	6.0	5.9	5.8	5.8
	-17	-18	6.3	6.3	6.1	6.0	5.9
	-15	-16	6.7	6.5	6.3	6.1	6.0
	-12	-13	7.0	6.9	6.7	6.6	6.5
	-10	-11	7.3	7.2	7.1	7.0	7.0
	-7	-8	7.8	7.7	7.6	7.4	7.2
	-5	-6	8.2	8.1	8.0	7.7	7.5
	-3	-4	8.6	8.5	8.4	8.1	7.7
	0	-1	9.0	8.9	8.8	8.4	8.0
	3	2.2	9.4	9.3	9.2	8.8	8.4
	5	4.1	9.9	9.7	9.6	9.0	8.4
	7	6	10.3	10.1	10.0	9.2	8.4
	9	7.9	10.6	10.3	10.0	9.2	8.4
	11	9.8	10.9	10.5	10.0	9.2	8.4
	13	12	11.2	10.6	10.0	9.2	8.4
15	14	11.6	10.8	10.0	9.2	8.4	
112	-20	-21	7.4	7.4	7.3	7.3	7.3
	-17	-18	8.0	7.8	7.6	7.5	7.4
	-15	-16	8.4	8.1	7.9	7.7	7.5
	-12	-13	8.8	8.6	8.4	8.2	8.1
	-10	-11	9.2	9.0	8.9	8.8	8.7
	-7	-8	9.7	9.6	9.4	9.2	9.0
	-5	-6	10.2	10.1	9.9	9.6	9.3
	-3	-4	10.7	10.6	10.5	10.1	9.7
	0	-1	11.3	11.3	11.1	10.5	10.0
	3	2.2	11.8	11.6	11.5	11.0	10.6
	5	4.1	12.3	12.2	12.0	11.3	10.6
	7	6	12.9	12.7	12.5	11.5	10.6
	9	7.9	13.3	12.9	12.5	11.5	10.6
	11	9.8	13.7	13.1	12.5	11.5	10.6
	13	12	14.0	13.3	12.5	11.5	10.6
15	14	14.4	13.5	12.5	11.5	10.6	
128	-20	-21	8.1	8.1	8.0	8.0	8.0
	-17	-18	8.7	8.5	8.4	8.3	8.1
	-15	-16	9.2	9.0	8.7	8.5	8.2
	-12	-13	9.7	9.5	9.3	9.1	8.9
	-10	-11	10.1	10.0	9.9	9.7	9.6
	-7	-8	10.7	10.6	10.4	10.2	10.0
	-5	-6	11.3	11.1	11.0	10.7	10.3
	-3	-4	11.9	11.7	11.5	11.1	10.7
	0	-1	12.4	12.3	12.1	11.6	11.0
	3	2.2	13.0	12.9	12.7	12.2	11.7
	5	4.1	13.6	13.4	13.2	12.4	11.7
	7	6	14.2	14.0	13.8	12.7	11.7
	9	7.9	14.6	14.2	13.8	12.7	11.7
	11	9.8	15.1	14.4	13.8	12.7	11.7
	13	12	15.5	14.7	13.8	12.7	11.7
15	14	15.9	14.9	13.8	12.7	11.7	
140	-20	-21	9.5	9.5	9.4	9.4	9.3
	-17	-18	10.1	9.9	9.6	9.6	9.4
	-15	-16	10.7	10.4	10.1	9.8	9.5
	-12	-13	11.2	11.0	10.8	10.6	10.3
	-10	-11	11.7	11.6	11.4	11.3	11.1
	-7	-8	12.4	12.2	12.1	11.8	11.5
	-5	-6	13.1	12.9	12.7	12.3	12.0
	-3	-4	13.8	13.6	13.4	12.9	12.4
	0	-1	14.4	14.2	14.0	13.4	12.8
	3	2.2	15.1	14.9	14.7	14.1	13.5
	5	4.1	15.8	15.6	15.3	14.4	13.5
	7	6	16.5	16.2	16.0	14.8	13.5
	9	7.9	17.0	16.5	16.0	14.8	13.5
	11	9.8	17.5	16.7	16.0	14.8	13.5
	13	12	18.0	17.0	16.0	14.8	13.5
15	14	18.5	17.2	16.0	14.8	13.5	

Indoor units

6

MSP(Middle static pressure) duct

6-3. Dimensional drawing

1) AVXDUH056/071E*

Unit:mm

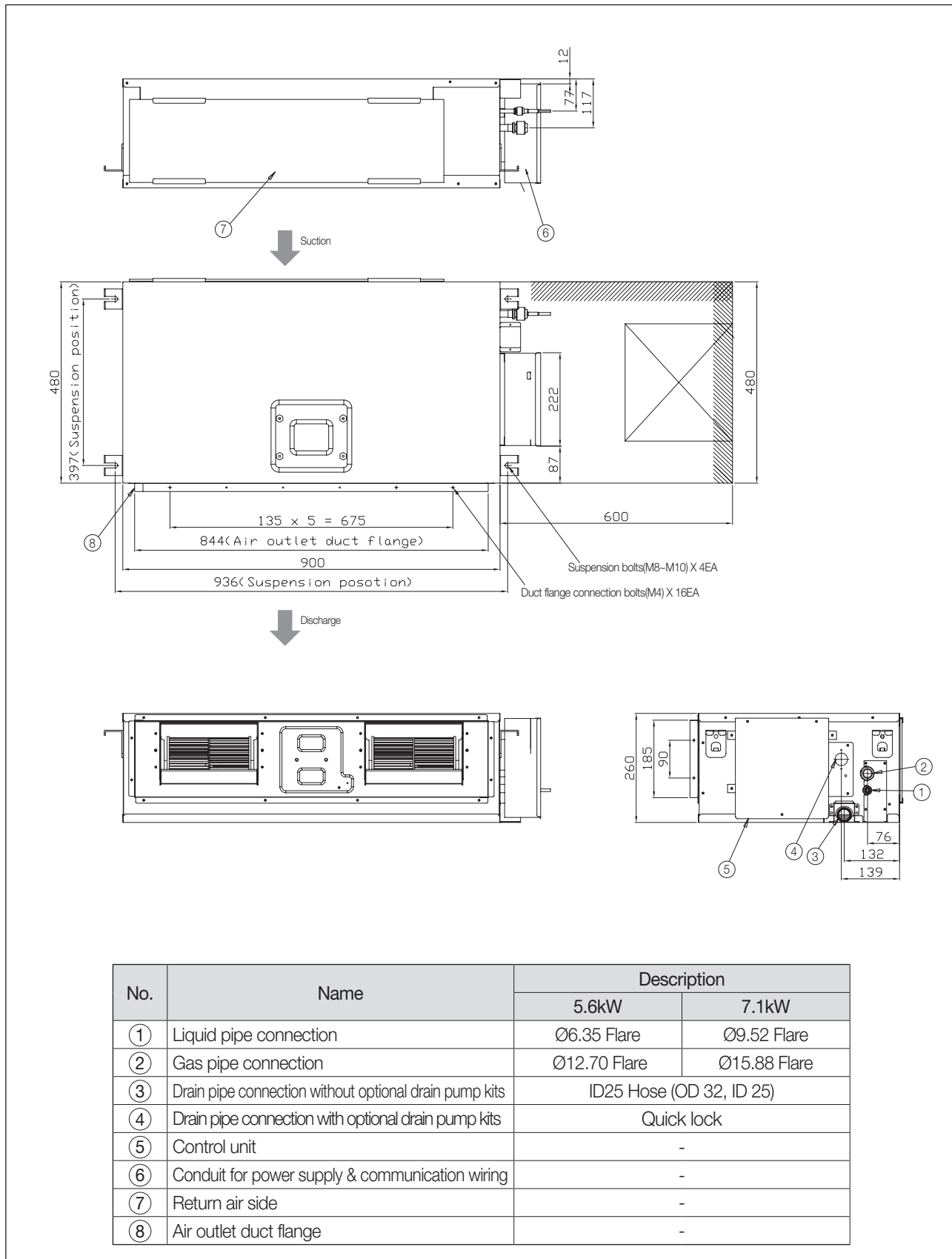

2) AVXDUH090E*

Unit:mm

Indoor units

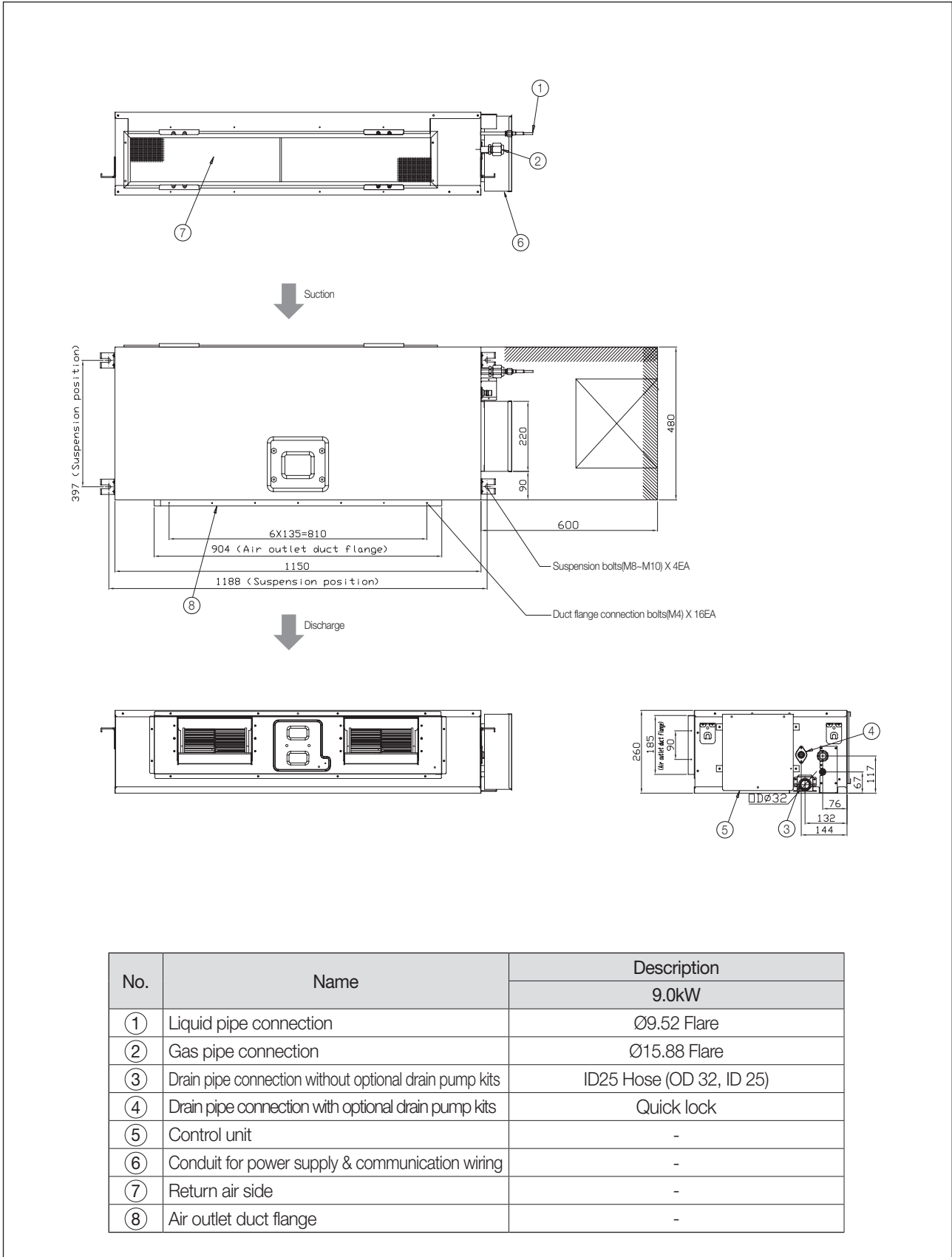

No.	Name	Description
		9.0kW
①	Liquid pipe connection	Ø9.52 Flare
②	Gas pipe connection	Ø15.88 Flare
③	Drain pipe connection without optional drain pump kits	ID25 Hose (OD 32, ID 25)
④	Drain pipe connection with optional drain pump kits	Quick lock
⑤	Control unit	-
⑥	Conduit for power supply & communication wiring	-
⑦	Return air side	-
⑧	Air outlet duct flange	-

6

MSP(Middle static pressure) duct

6-3. Dimensional drawing

3) AVXDUH112E*

Unit:mm

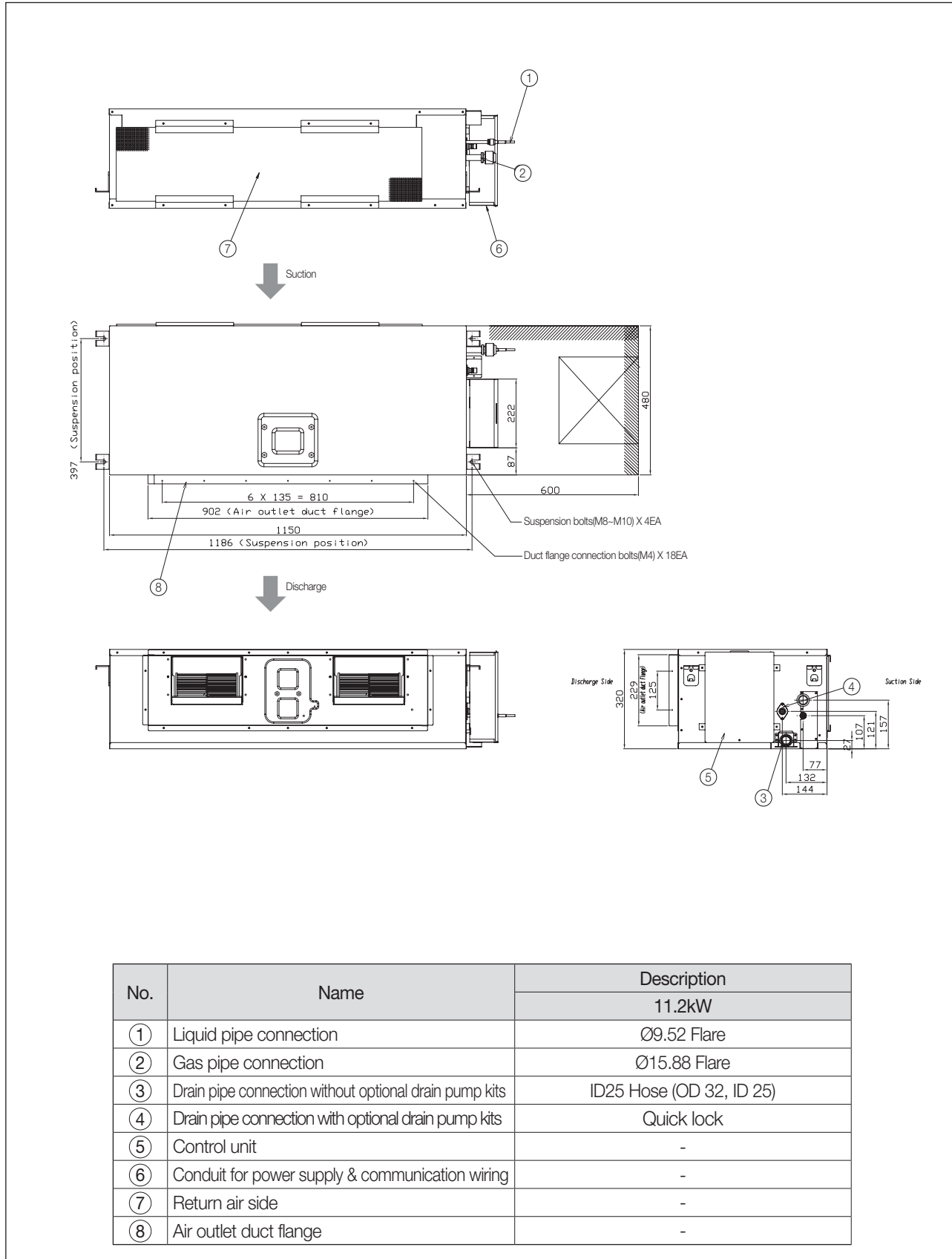

4) AVXDUH128/140E*

Unit:mm

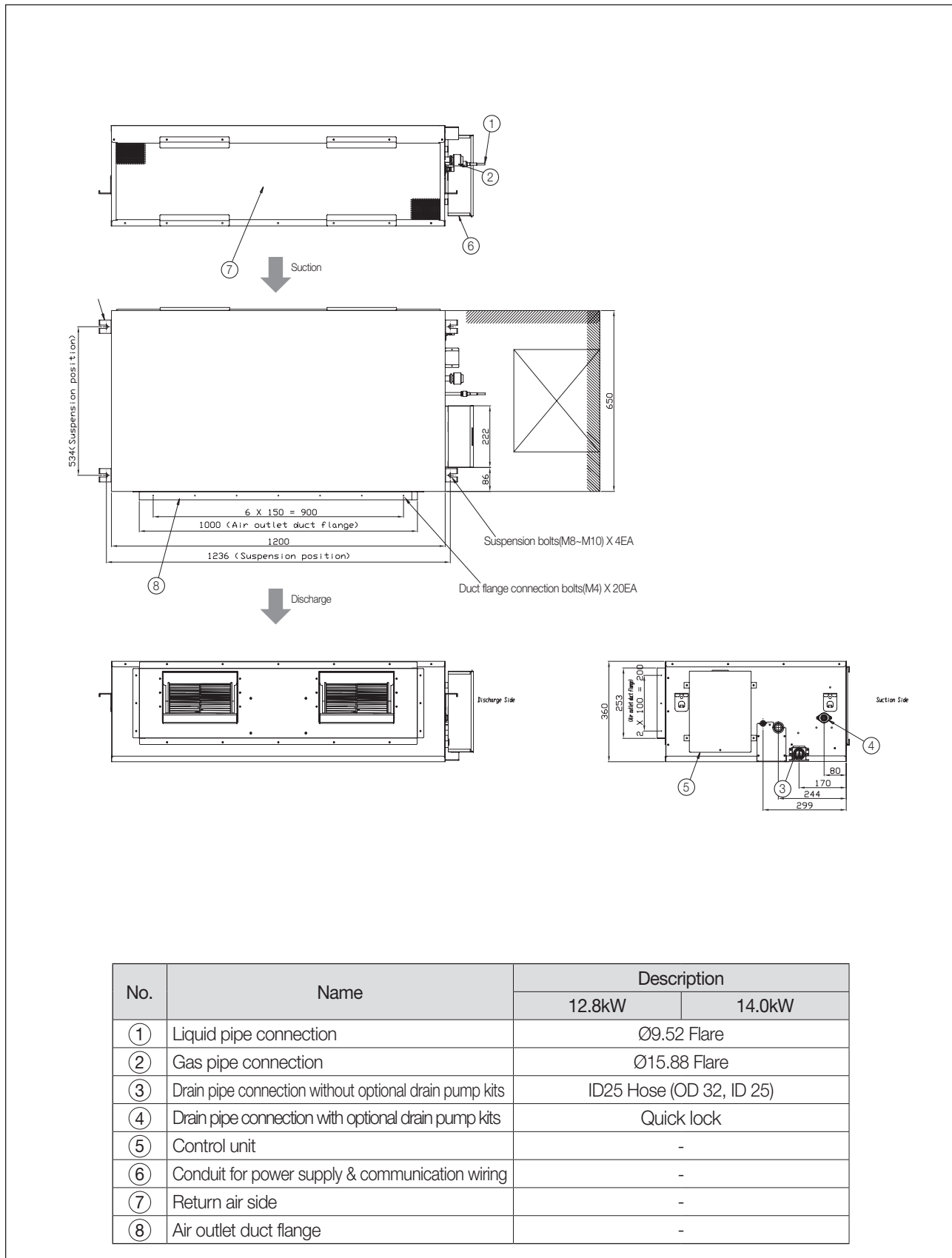

Indoor units

No.	Name	Description	
		12.8kW	14.0kW
①	Liquid pipe connection	Ø9.52 Flare	
②	Gas pipe connection	Ø15.88 Flare	
③	Drain pipe connection without optional drain pump kits	ID25 Hose (OD 32, ID 25)	
④	Drain pipe connection with optional drain pump kits	Quick lock	
⑤	Control unit	-	
⑥	Conduit for power supply & communication wiring	-	
⑦	Return air side	-	
⑧	Air outlet duct flange	-	

6-4. PCB connector lay-out

1) AVXDUH056/071E*

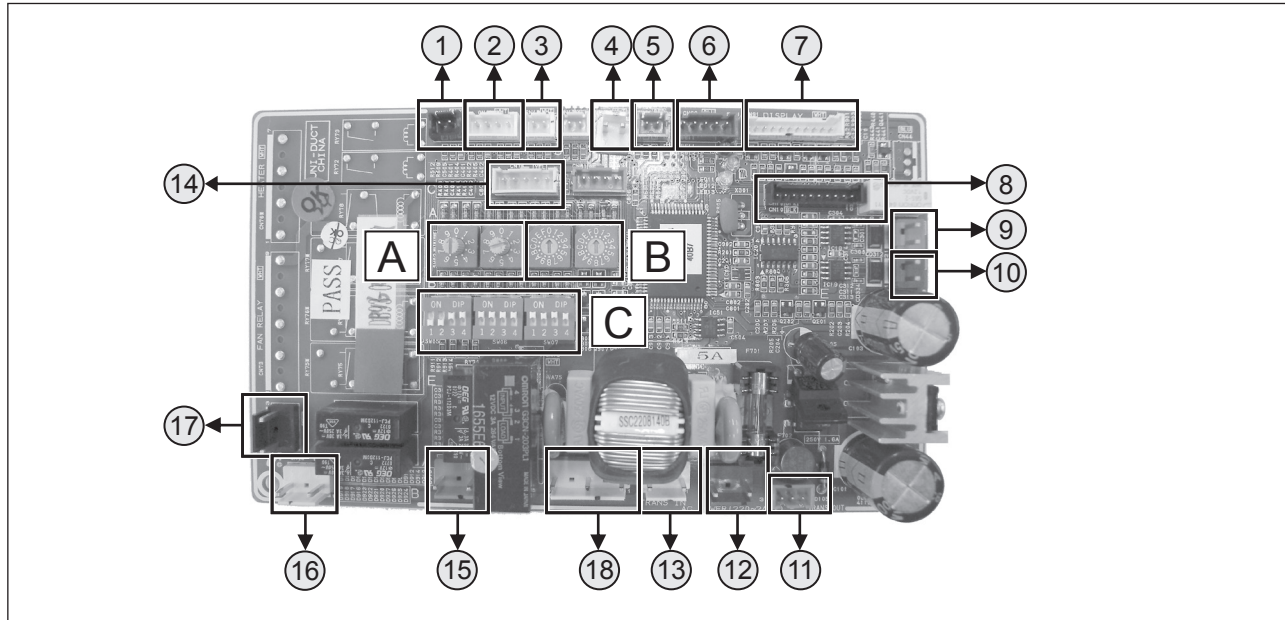

No.	CN #	COLOR	FUNCTION
①	CN51	Black	Float Switch
②	CN41	White	Room Sensor, Eva-In Sensor
③	CN42	White	Eva-Out Sensor
④	CN32	White	DC12V for Wired Remote Controller
⑤	CN83	Red	External Contact Control
⑥	CN62	Blue	EEV
⑦	CN91	White	Display
⑧	CN10	White	MICOM Download
⑨	CN31	Red	Communication with Outdoor Units (COM1)
⑩	CN33	Blue	Communication with Wired Remote Controller (COM2)
⑪	CN11	Red	Trans-Out (AC 17V)
⑫	CN71	Blue	AC 230V Input
⑬	CN72	White	Trans-In (AC 230V)
⑭	CN77	Red	Hot Water Coil
⑮	CN81	Red	Error Check, Indoor unit Operation
⑯	CN74	Yellow	Drain Pump
⑰	CN75	Black	Ventilator
⑱	CN78	White	Fan Motor

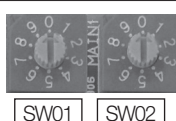
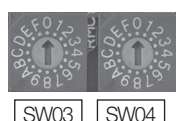
No.	S/W	FUNCTION	
A		Main Address Setting (00~63)	
	SW01 SW02		
B		Address of Interface Module Channel 0~2	
	SW03 SW04		
	SW03	SW04	Group Address (RMC) for Centralized Control 0~F

No.	S/W	FUNCTION	ON	OFF
C	K1	-	-	-
	K2	Centralized Controller	Not use	Use
	K3	RPM Up	N/A	N/A
	K4	Optional Drain Pump	Not use	Use
	K5	Heating Thermo-off	+2°C	+5°C
	K6	Filter Signal Display	1,000hrs	2,000hrs
	K7	Hot Water Coil	N/A	N/A
	K8	Electrical Heater	N/A	N/A
	K9	Min. EEV Step at Heating	Fixed 80 step	0 or 80 step
	K10	Priority of Indoor unit Display on Wired Remote Controlle	Slave (Default)	Master
	K11	External Contact Control	Not use	Use
	K12	-	-	-

2) AVXDUH090/112/128/140E*

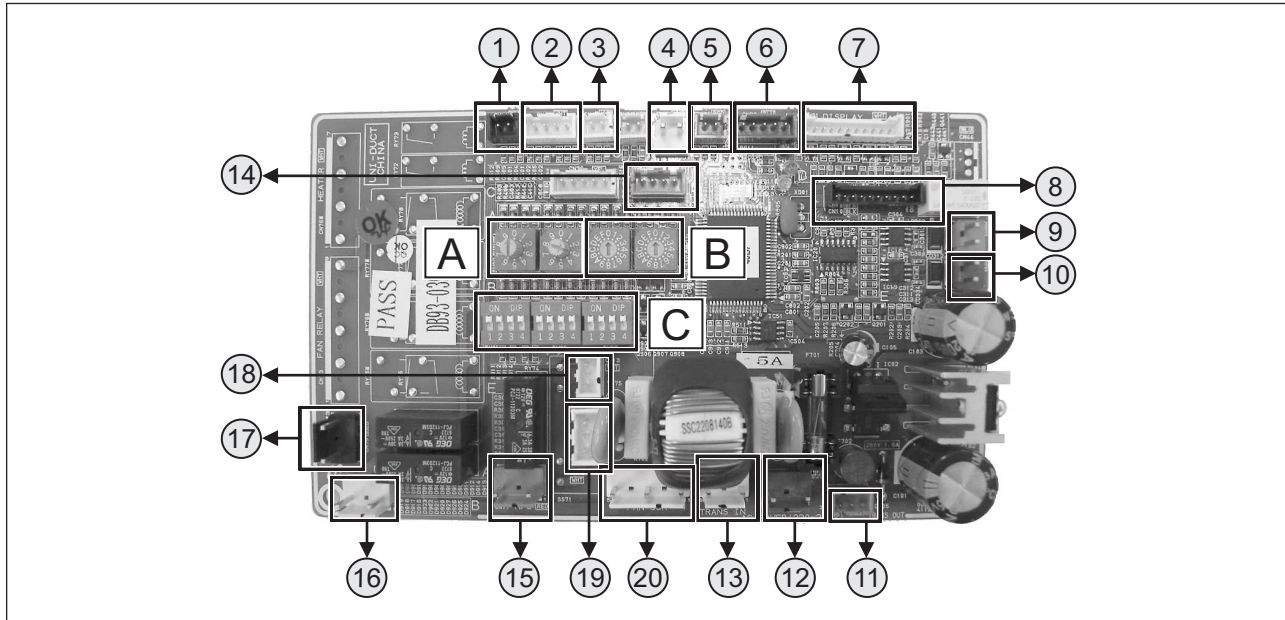

No.	CN #	COLOR	FUNCTION
①	CN51	Black	Float Switch
②	CN41	White	Room Sensor, Eva-In Sensor
③	CN42	White	Eva-Out Sensor
④	CN32	White	DC12V for Wired Remote Controller
⑤	CN83	Red	External Contact Control
⑥	CN62	Blue	EEV
⑦	CN91	White	Display
⑧	CN10	White	MICOM Download
⑨	CN31	Red	Communication with Outdoor Units (COM1)
⑩	CN33	Blue	Communication with Wired Remote Controller (COM2)
⑪	CN11	Red	Trans-Out (AC 17V)
⑫	CN71	Blue	AC 230V Input
⑬	CN72	White	Trans-In (AC 230V)
⑭	CN77	Red	Hot Water Coil
⑮	CN81	Red	Error Check, Indoor unit Operation
⑯	CN74	Yellow	Drain Pump
⑰	CN75	Black	Ventilator
⑱	CN13	White	SSR Control Signal
⑲	CN79	White	SSR Power
⑳	CN78	White	Fan Motor

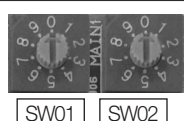
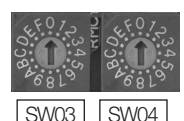
No.	S/W	FUNCTION
A	 SW01 SW02	Main Address Setting (00~63)
B	 SW03 SW04	SW03: Address of Interface Module Channel 0~2 SW04: Group Address (RMC) for Centralized Control 0~F

No.	S/W	FUNCTION	ON	OFF
C	K1	-	-	-
	K2	Centralized Controller	Not use	Use
	K3	RPM Up	N/A	N/A
	K4	Optional Drain Pump	Not use	Use
	K5	Heating Thermo-off	+2°C	+5°C
	K6	Filter Signal Display	1,000hrs	2,000hrs
	K7	Hot Water Coil	Not use	Use
	K8	Electrical Heater	N/A	N/A
	K9	Min. EEV Step at Heating	Fixed 80 step	0 or 80 step
	K10	Priority of Indoor unit Display on Wired Remote Controlle	Slave (Default)	Master
	K11	External Contact Control	Not use	Use
	K12	-	-	-

6

MSP(Middle static pressure) duct

6-5. Electrical wiring diagram

1) AVXDUH056/071E*

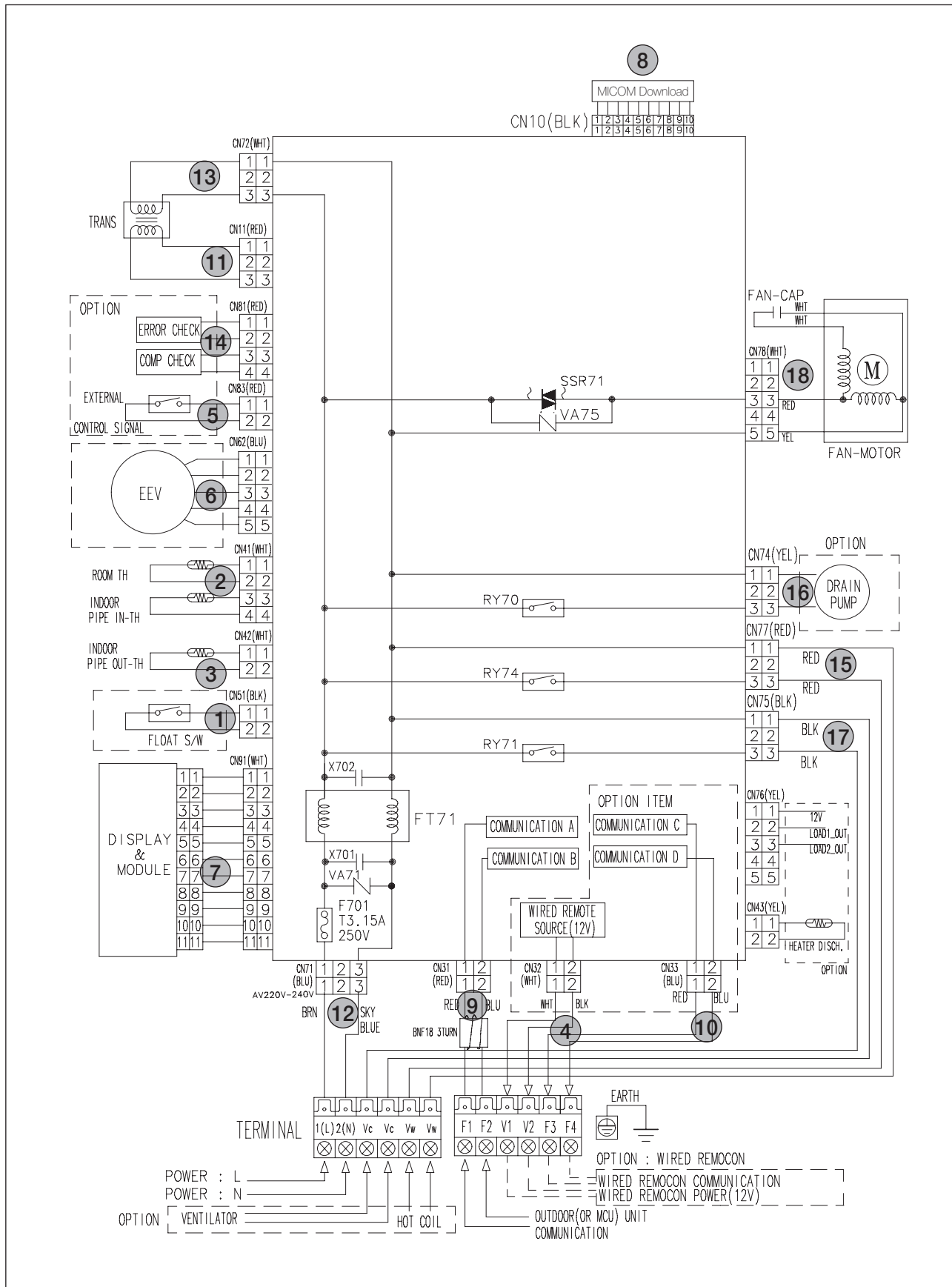

2) AVXDUH090/112/128/140E*

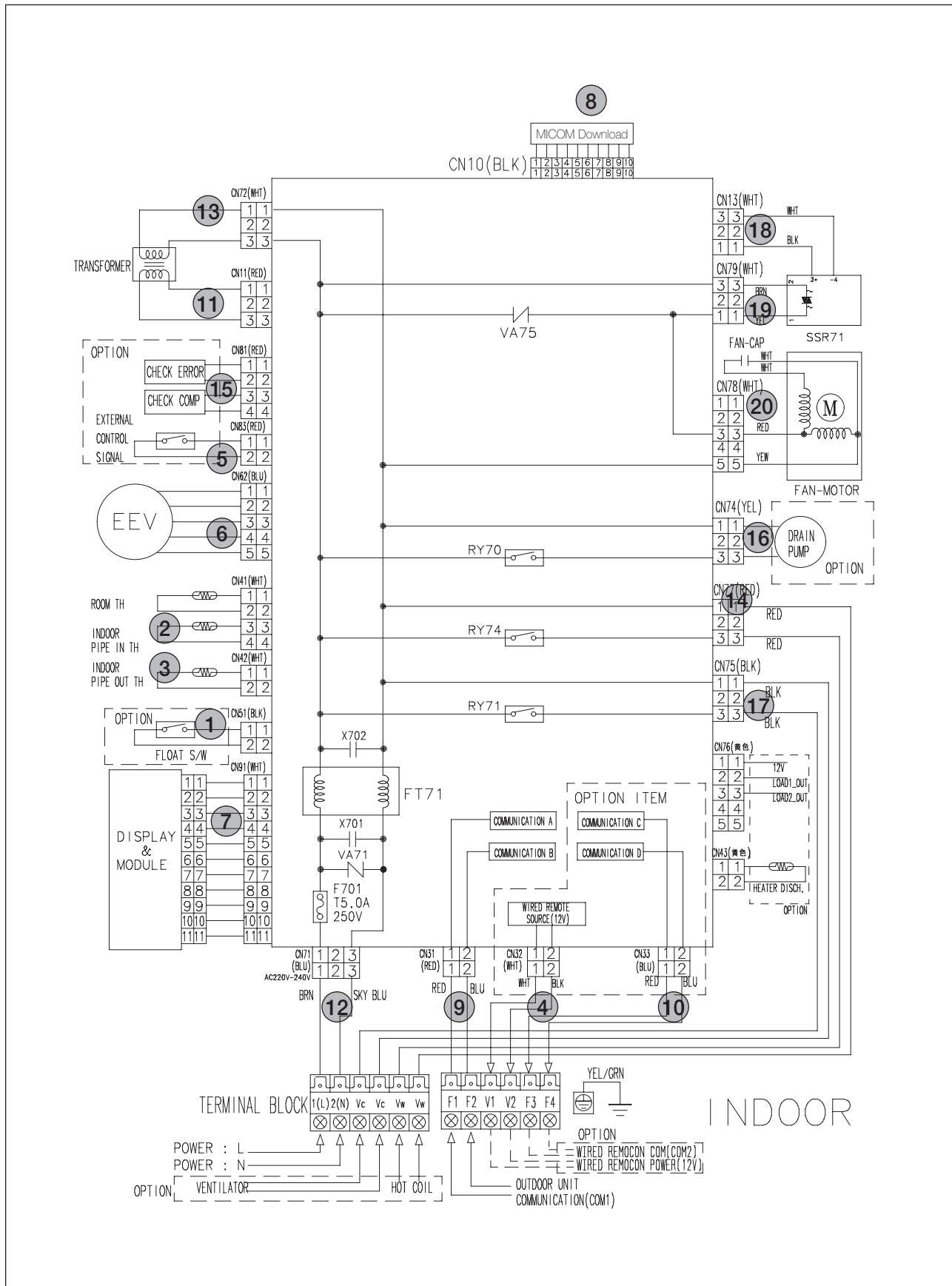

Indoor units

6-6. Sound pressure level

1) Operation sound level

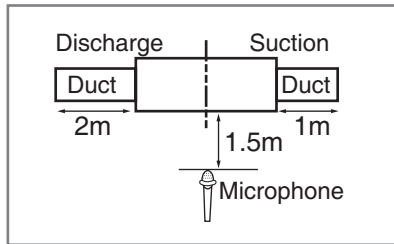

Unit : dB(A)

Model	High	Low
AVXDUH056E*	37	33
AVXDUH071E*	39	35
AVXDUH090E*	39	35
AVXDUH112E*	39	35
AVXDUH128E*	39	35
AVXDUH140E*	43	38

Note

- ◆ These operation values were obtained in a dead room. Sound pressure level will vary depending on a range of factors such as the construction of the particular room where the equipment is installed.
- ◆ Operation sound level may differ depending on operation and ambient conditions.

2) NC curves

(1) AVXDUH056E*

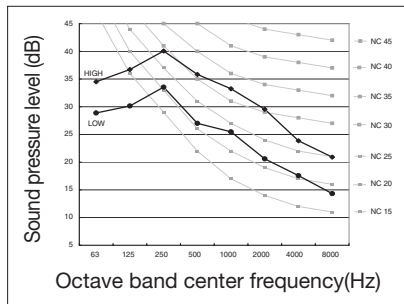

(2) AVXDUH071E*

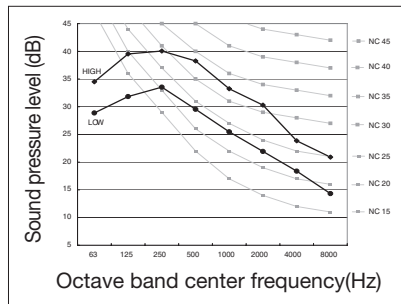

(3) AVXDUH090E*

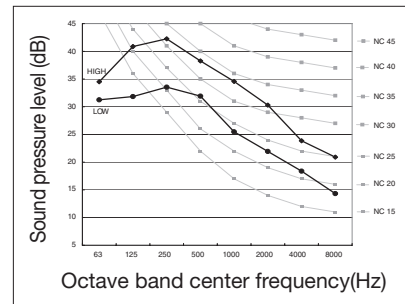

(4) AVXDUH112E*

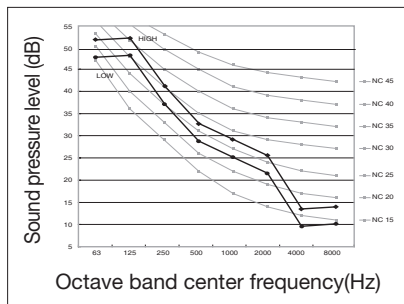

(5) AVXDUH128E*

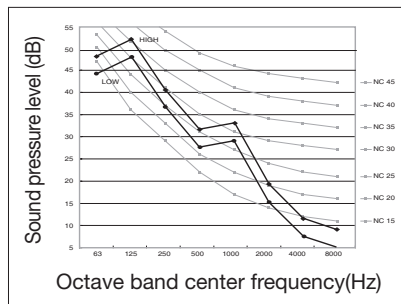

(6) AVXDUH140E*

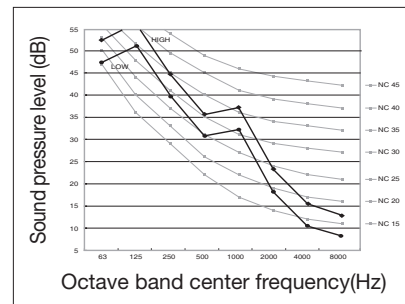

6-7. Recommended operation range

(1) AVXDUH056E*

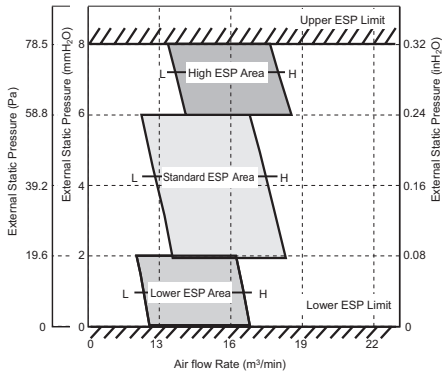

External Static pressure (mmAq)	Option code
0	0152211A0371-200000300000
4	0152211A03C5-200000300000
6	0152211A03F5-200000300000
8	0152231A0157-200000300000

(2) AVXDUH071E*

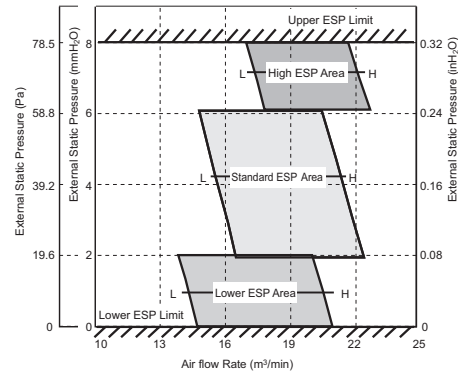

External Static pressure (mmAq)	Option code
0	0152231C0104-200000300000
4	0152231C0179-200000300000
6	0152231C03F9-200000300000
8	0152231C03FC-200000300000

(3) AVXDUH090E*

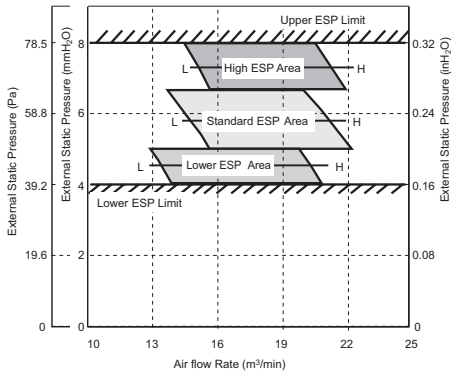

External Static pressure (mmAq)	Option code
4	0152231E0145-200000300000
6	0152231E0329-200000300000
8	0152231E03FD-200000300000

(4) AVXDUH112E*

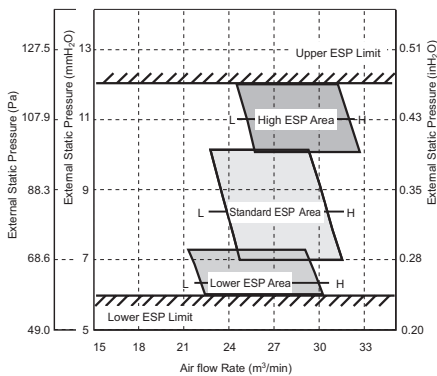

External Static pressure (mmAq)	Option code
6	012A24-100226-200000300000
8	012A241002BB-200000300000
10	012A241003F0-200000300000
12	012A241003F0-200000300000

(5) AVXDUH128E*

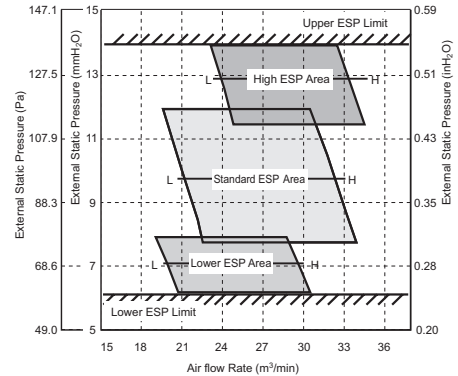

External Static pressure (mmAq)	Option code
6	012A23-12019E-200000300000
8	012A241200B0-200000300000
10	012A241200E2-200000300000
12	012A24120214-200000300000
14	012A24120236-200000300000

(6) AVXDUH140E*

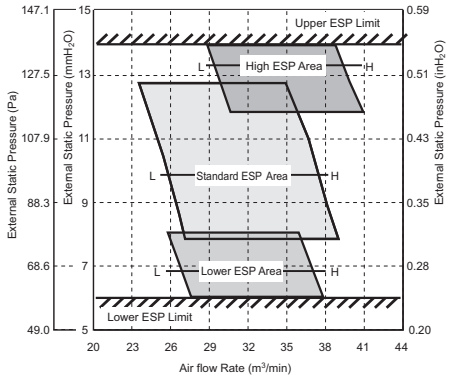

External Static pressure (mmAq)	Option code
6	012A24-1300F2-200000300000
8	012A24130224-200000300000
10	012A24130247-200000300000
12	012A241302AA-200000300000
14	012A241302FC-200000300000

Note

- ◆ ESP = External Static Pressure
- ◆ The graphs display the available external static pressure range of installed indoor units. Therefore, they do not reflect the actual change of external static pressure and airflow rate according to adjusted airflow (High-Mid-Low) of installed indoor units.



INDOOR UNIT



7 HSP(High static pressure) duct (ND***HHXE*)

7-1. Specifications.....	94
7-2. Capacity tables	95
7-3. Dimensional drawing.....	97
7-4. PCB connector lay-out.....	99
7-5. Electrical wiring diagram	101
7-6. Sound pressure level	103
7-7. Recommended operation range	104

Optional Accessories

Individual Controllers



MWR-WE10



MWR-WH00



MWR-SH00



MR-DH00



MRK-A00



MRW-10A

Drain Pump



MDP-M076SGU2
MDPN047SNC1

7-1. Specifications

1) Technical specifications

Model				ND112HHXEB	ND128HHXEB	ND140HHXEB	ND220HHXEA	ND280HHXEA	
Power Supply			Ø, #, V, Hz	1, 2, 220~240, 50	1, 2, 220~240, 50	1, 2, 220~240, 50	1, 2, 220~240, 50	1, 2, 220~240, 50	
Mode ^{*1)}				HP / HR	HP / HR	HP / HR	HP / HR	HP / HR	
Capacity (Nominal)	Cooling ^{*2)}	kW		11.2	12.8	14.0	22.4	28.0	
		Btu/h		38,200	43,700	47,800	76,400	95,500	
	Heating ^{*3)}	kW		12.5	13.8	16.0	25	31.5	
		Btu/h		42,700	47,100	54,600	85,300	107,500	
Power	Power Input (Nominal)	Cooling ^{*2)}	W		510	560	625	0.53	0.79
			Heating ^{*3)}		510	560	625	0.53	0.79
	Current Input (Nominal)	Cooling ^{*2)}	A		3.60	3.75	3.90	3.8	5.9
			Heating ^{*3)}		3.60	3.75	3.90	3.8	5.9
Fan	Motor	Type	-	Sirocco Fan / AC	Sirocco Fan / AC	Sirocco Fan / AC	BLDC	BLDC	
		Output	W	-	-	-	-	-	
		Number of unit	EA	2	2	2	1	1	
	Air Flow Rate	H/M/L (UL)	CMM		32 / 27 / 23	35 / 31 / 26	39 / 33 / 28	58 / 52 / 47	72 / 65 / 58
			CFM		-	-	-	-	-
	External Pressure	Min / Std / Max	mmAq		5 / 10 / 20	5 / 10 / 20	5 / 10 / 20	5 / 15 / 25	5 / 15 / 28
			Pa		49 / 98.1 / 196.1	49 / 98.1 / 196.1	49 / 98.1 / 196.1	49/147.1/246.1	49/147.1/274.2
			WG		-	-	-	-	-
Option Code			-	015A23-10013A-200000-300000	015A23-12017C-200000-300000	015A23-1301CF-200000-300000	015A17-1600E8-200000-300000	015A17-17025B-200000-300000	
Piping Connections	Liquid Pipe	Ø, mm		9.52	9.52	9.52	9.52	9.52	
		Ø, inch		3/8	3/8	3/8	3/8	3/8	
		Ø, mm		15.88	15.88	15.88	19.05	22.22	
	Gas Pipe	Ø, inch		5/8	5/8	5/8	3/4	7/8	
		Ø, mm		ID25 Hose (OD 32, ID 25)	ID25 Hose (OD 32, ID 25)	ID25 Hose (OD 32, ID 25)	ID25 Hose (OD32, ID25)	ID25 Hose (OD32, ID25)	
	Field Wiring	Power Source Wire	Below 20m / over 20m	mm ²	1.5 / 2.5	1.5 / 2.5	1.5 / 2.5	1.5 ~ 2.5	1.5 ~ 2.5
Transmission Cable			mm ²	0.75 / 1.5	0.75 / 1.5	0.75 / 1.5	0.75 ~ 1.5	0.75 ~ 1.5	
Refrigerant	Type	-		R410A	R410A	R410A	R410A	R410A	
	Control Method	-		EEV	EEV	EEV	EEV	EEV	
Sound	Sound Pressure	High / Low ^{*4)}	dBA	43 / 39	44 / 40	45 / 41	47 / 44	48 / 45	
Dimensions	Net Weight		kg	62	62	62	95	95	
	Shipping Weight		kg	70	70	70	105	105	
	Net Dimensions (W×H×D)		mm	1,200 x 360 x 650	1,200 x 360 x 650	1,200 x 360 x 650	1,240 x 470 x 1,040	1,240 x 470 x 1,040	
	Shipping Dimensions (W×H×D)		mm	1,447 x 425 x 769	1,447 x 425 x 769	1,447 x 425 x 769	1,507 x 558 x 1,155	1,507 x 558 x 1,155	
Panel Size	Panel model		-	-	-	-	-	-	
	Panel Net Weight		kg	-	-	-	-	-	
	Shipping Weight		kg	-	-	-	-	-	
	Net Dimensions (W×H×D)		mm	-	-	-	-	-	
	Shipping Dimensions (W×H×D)		mm	-	-	-	-	-	
Additional Accessories	Drain pump	Drain pump	- / Model	Optional / MDP-M075SGU2	Optional / MDP-M075SGU2	Optional / MDP-M075SGU2	Optional / MDP-N047SNC1	Optional / MDP-N047SNC1	
		Max. lifting Height / Displacement	mm/liter/h	750 / 24	750 / 24	750 / 24	470 / 24	470 / 24	
	Air Filter		-		Long life filter	Long life filter	Long life filter	Long life filter	Long life filter

* Specifications may be subject to change without prior notice for product improvement.

*1) Mode

- HP : Heat Pump, HR : Heat Recovery

*2) Nominal cooling capacities are based on;

- Indoor temperature : 27°C DB, 19°C WB

- Outdoor temperature : 35°C DB, 24°C WB, Equivalent refrigerant piping : 7.5m, Level differences : 0m

*3) Nominal heating capacities are based on;

- Indoor temperature : 20°C DB, 15°C WB

- Outdoor temperature : 7°C DB, 6°C WB, Equivalent refrigerant piping : 7.5m, Level differences : 0m

*4) Sound pressure was acquired in a dead room. Thus actual noise level may be different depending on the installation conditions.

7-2. Capacity tables

1) Cooling

TC : Total Capacity(kW), SHC : Sensible Heat Capacity(kW)

Model	Outdoor temperature (°C, DB)	Indoor temperature (°C, WB)														
		20 (°C, DB)		23 (°C, DB)		26 (°C, DB)		27 (°C, DB)		28(°C, DB)		30 (°C, DB)		32 (°C, DB)		
		14 (°C, WB)		16 (°C, WB)		18 (°C, WB)		19 (°C, WB)		20 (°C, WB)		22 (°C, WB)		24 (°C, WB)		
		TC	SHC	TC	SHC	TC	SHC	TC	SHC	TC	SHC	TC	SHC	TC	SHC	
112	10	8.5	7.0	9.3	7.5	10.7	8.3	11.2	8.5	11.7	8.6	12.5	8.3	13.6	8.4	
	12	8.5	7.0	9.3	7.5	10.7	8.3	11.2	8.5	11.7	8.6	12.5	8.3	13.6	8.4	
	14	8.5	7.0	9.3	7.5	10.7	8.3	11.2	8.5	11.7	8.6	12.5	8.3	13.5	8.3	
	16	8.5	7.0	9.3	7.5	10.7	8.3	11.2	8.5	11.7	8.6	12.5	8.3	13.5	8.3	
	18	8.5	7.0	9.3	7.5	10.7	8.3	11.2	8.5	11.7	8.6	12.4	8.2	13.4	8.3	
	20	8.5	7.0	9.3	7.5	10.7	8.3	11.2	8.5	11.7	8.6	12.4	8.2	13.4	8.3	
	21	8.5	7.0	9.3	7.5	10.7	8.3	11.2	8.5	11.7	8.6	12.4	8.2	13.4	8.3	
	23	8.5	7.0	9.3	7.5	10.7	8.3	11.2	8.5	11.7	8.6	12.4	8.2	13.4	8.3	
	25	8.5	7.0	9.3	7.5	10.7	8.3	11.2	8.5	11.7	8.6	12.4	8.2	13.4	8.3	
	27	8.5	7.0	9.3	7.5	10.7	8.3	11.2	8.5	11.7	8.6	12.4	8.2	13.4	8.3	
	29	8.5	7.0	9.3	7.5	10.7	8.3	11.2	8.5	11.7	8.6	12.4	8.2	13.4	8.3	
	31	8.5	7.0	9.3	7.5	10.7	8.3	11.2	8.5	11.7	8.6	12.4	8.2	13.4	8.3	
	33	8.5	7.0	9.3	7.5	10.7	8.3	11.2	8.5	11.7	8.6	12.4	8.2	13.4	8.3	
	35	8.5	7.0	9.3	7.5	10.7	8.3	11.2	8.5	11.7	8.6	12.4	8.2	13.4	8.3	
	37	8.5	7.0	9.3	7.5	10.7	8.3	11.2	8.5	11.7	8.6	12.3	8.2	13.2	8.2	
	39	8.5	7.0	9.3	7.5	10.7	8.3	11.2	8.5	11.6	8.5	12.1	8.0	13.0	8.0	
	42	8.5	7.0	9.3	7.5	10.7	8.3	10.9	8.3	11.3	8.3	11.6	7.7	12.6	7.8	
	44	8.5	7.0	9.3	7.5	10.7	8.3	10.9	8.3	11.3	8.3	11.6	7.7	12.4	7.7	
	128	10	9.7	8.0	10.4	8.3	12.0	8.9	12.8	10.0	13.3	10.0	14.3	9.8	15.4	9.8
		12	9.7	8.0	10.4	8.3	12.0	8.9	12.8	10.0	13.3	10.0	14.3	9.8	15.3	9.7
14		9.7	8.0	10.4	8.3	12.0	8.9	12.8	10.0	13.3	10.0	14.3	9.8	15.3	9.7	
16		9.7	8.2	10.4	8.3	12.0	8.9	12.8	10.0	13.3	10.0	14.2	9.7	15.2	9.6	
18		9.7	8.2	10.4	8.3	12.0	8.9	12.8	10.0	13.3	10.0	14.2	9.7	15.1	9.6	
20		9.7	8.2	10.4	8.3	12.0	8.9	12.8	10.0	13.3	10.0	14.2	9.7	15.1	9.6	
21		9.7	8.2	10.4	8.3	12.0	8.9	12.8	10.0	13.3	10.0	14.2	9.7	15.1	9.6	
23		9.7	8.2	10.4	8.3	12.0	8.9	12.8	10.0	13.3	10.0	14.2	9.7	15.1	9.6	
25		9.7	8.2	10.4	8.3	12.0	8.9	12.8	10.0	13.3	10.0	14.2	9.7	15.1	9.6	
27		9.7	8.2	10.4	8.3	12.0	8.9	12.8	10.0	13.3	10.0	14.2	9.7	15.1	9.6	
29		9.7	8.2	10.4	8.3	12.0	8.9	12.8	10.0	13.3	10.0	14.2	9.7	15.1	9.6	
31		9.7	8.2	10.4	8.3	12.0	8.9	12.8	10.0	13.3	10.0	14.2	9.7	15.1	9.6	
33		9.7	8.2	10.4	8.3	12.0	8.9	12.8	10.0	13.3	10.0	14.2	9.7	15.1	9.6	
35		9.7	8.2	10.4	8.3	12.0	8.9	12.8	10.0	13.3	10.0	14.2	9.7	15.1	9.6	
37		9.7	8.2	10.4	8.3	12.0	8.9	12.8	10.0	13.2	9.9	14.0	9.6	14.9	9.4	
39		9.7	8.2	10.4	8.3	12.0	8.9	12.8	10.0	13.1	9.8	13.8	9.4	14.5	9.2	
42		9.7	8.2	10.4	8.3	12.0	8.9	12.4	9.7	12.7	9.5	13.2	9.0	13.7	8.7	
44		9.7	8.2	10.4	8.3	12.0	8.9	12.4	9.7	12.7	9.5	13.2	9.0	13.7	8.7	
140		10	10.5	9.1	11.6	9.9	13.3	10.9	14.0	11.2	14.7	11.3	15.7	11.0	16.8	10.9
		12	10.5	9.1	11.6	9.9	13.3	10.9	14.0	11.2	14.6	11.2	15.6	10.9	16.7	10.9
	14	10.5	9.1	11.6	9.9	13.3	10.9	14.0	11.2	14.6	11.2	15.6	10.9	16.7	10.9	
	16	10.5	9.1	11.6	9.9	13.3	10.9	14.0	11.2	14.6	11.2	15.6	10.9	16.6	10.8	
	18	10.5	9.1	11.6	9.9	13.3	10.9	14.0	11.2	14.6	11.2	15.5	10.9	16.6	10.8	
	20	10.5	9.1	11.6	9.9	13.3	10.9	14.0	11.2	14.6	11.2	15.5	10.9	16.5	10.7	
	21	10.5	9.1	11.6	9.9	13.3	10.9	14.0	11.2	14.6	11.2	15.5	10.9	16.5	10.7	
	23	10.5	9.1	11.6	9.9	13.3	10.9	14.0	11.2	14.6	11.2	15.5	10.9	16.5	10.7	
	25	10.5	9.1	11.6	9.9	13.3	10.9	14.0	11.2	14.6	11.2	15.5	10.9	16.5	10.7	
	27	10.5	9.1	11.6	9.9	13.3	10.9	14.0	11.2	14.6	11.2	15.5	10.9	16.5	10.7	
	29	10.5	9.1	11.6	9.9	13.3	10.9	14.0	11.2	14.6	11.2	15.5	10.9	16.5	10.7	
	31	10.5	9.1	11.6	9.9	13.3	10.9	14.0	11.2	14.6	11.2	15.5	10.9	16.5	10.7	
	33	10.5	9.1	11.6	9.9	13.3	10.9	14.0	11.2	14.6	11.2	15.5	10.9	16.5	10.7	
	35	10.5	9.1	11.6	9.9	13.3	10.9	14.0	11.2	14.6	11.2	15.5	10.9	16.5	10.7	
	37	10.5	9.1	11.6	9.9	13.3	10.9	14.0	11.2	14.6	11.2	15.4	10.8	16.3	10.6	
	39	10.5	9.1	11.6	9.9	13.3	10.9	14.0	11.2	14.5	11.2	15.1	10.6	15.9	10.3	
	42	10.5	9.1	11.6	9.9	13.3	10.9	13.6	10.9	14.1	10.9	14.4	10.1	15.0	9.8	
	44	10.5	9.1	11.6	9.9	13.3	10.9	13.6	10.9	14.1	10.9	14.4	10.1	15.0	9.8	
	220	10	15.8	13.8	18.7	15.4	21.2	16.6	22.4	17.1	23.9	17.7	26.4	18.1	27.9	18.3
		12	15.8	13.8	18.7	15.4	21.2	16.6	22.4	17.1	23.9	17.8	26.4	18.2	27.9	18.4
14		15.8	13.8	18.7	15.4	21.2	16.6	22.4	17.1	23.9	17.8	26.4	18.2	27.9	18.1	
16		15.8	13.8	18.7	15.4	21.2	16.6	22.4	17.1	23.9	17.8	26.4	18.2	27.9	18.3	
18		15.8	13.8	18.7	15.4	21.2	16.6	22.4	17.1	23.9	17.8	26.4	18.2	27.8	18.1	
20		15.8	13.8	18.7	15.4	21.2	16.6	22.4	17.1	23.9	17.8	26.4	18.2	27.4	18.0	
21		15.8	13.8	18.7	15.4	21.2	16.6	22.4	17.1	23.9	17.8	26.4	18.2	27.5	18.0	
23		15.8	13.8	18.7	15.4	21.2	16.6	22.4	17.1	23.9	17.8	26.4	18.3	27.1	17.7	
25		15.8	13.8	18.7	15.4	21.2	16.6	22.4	17.1	23.9	17.8	26.4	18.2	27.0	17.8	
27		15.8	13.8	18.7	15.4	21.2	16.6	22.4	17.1	23.9	17.8	26.4	18.2	27.0	17.8	
29		15.8	13.8	18.7	15.4	21.2	16.6	22.4	17.1	23.9	17.8	26.4	18.2	27.0	17.8	
31		15.8	13.8	18.7	15.4	21.2	16.6	22.4	17.1	23.9	17.8	26.4	18.3	27.0	17.8	
33		15.8	13.8	18.7	15.4	21.2	16.6	22.4	17.1	23.9	17.8	26.4	18.5	27.0	17.8	
35		15.8	13.8	18.7	15.4	21.2	16.6	22.4	17.1	23.9	17.7	26.4	18.5	27.0	18.0	
37		15.5	13.6	18.4	15.2	21.1	16.5	22.4	17.1	23.7	17.7	26.0	18.2	26.6	17.6	
39		15.3	13.5	18.1	15.0	21.1	16.5	22.3	17.0	23.7	17.7	25.7	18.4	26.2	17.5	
42		15.0	13.2	17.8	14.7	20.7	16.2	21.9	16.7	23.3	17.5	25.2	18.1	25.7	17.3	
44		14.8	13.0	17.5	14.5	20.4	15.9	21.6	16.4	22.9	17.3	24.8	17.9	25.3	17.0	
46		14.5	12.7	17.2	14.2	20.0	15.6	21.2	16.1	22.5	16.9	24.4	17.5	24.8	16.6	
280		10	19.7	17.6	23.3	19.6	26.5	21.2	28.0	21.8	29.9	22.6	32.7	23.0	34.7	23.2
	12	19.7	17.6	23.3	19.6	26.5	21.2	28.0	21.8	29.9	22.8	32.7	23.1	34.7	23.4	
	14	19.7	17.6	23.3	19.6	26.5	21.2	28.0	21.8	29.9	22.8	32.7	23.1	34.7	23.0	
	16	19.7	17.6	23.3	19.6	26.5	21.2	28.0	21.8	29.9	22.8	32.7	23.1	34.7	23.3	
	18	19.7	17.6	23.3	19.6	26.5	21.2	28.0	21.8	29.9	22.8	32.7	23.0	34.7	23.1	
	20	19.7	17.6	23.3	19.6	26.5	21.2	28.0	21.8	29.9	22.8	32.7	23.0	34.3	23.0	
	21	19.7	17.6	23.3	19.6	26.5	21.2	28.0	21.8	29.9	22.8	32.7	23.0	34.3	22.9	
	23	19.7	17.6	23.3	19.6	26.5	21.2	28.0	21.8	29.9	22.8	32.7	23.2	33.7	22.6	
	25	19.7	17.6	23.3	19.6	26.5	21.2	28.0	21.8	29.9	22.8	32.7	23.0	33.7	22.8	
	27	19.7	17.6	23.3	19.6	26.5	21.2	28.0	21.8	29.9	22.8	32.7	23.0	33.7	22.8	
	29	19.7	17.6	23.3	19.6	26.5	21.2	28.0	21.8	29.9	22.8	32.7	23.0	33.7	22.8	
	31	19.7	17.6	23.3	19.6	26.5	21.2	28.0	21.8	29.9	22.8	32.7	23.2	33.7	22.8	
	33	19.7	17.6	23.3	19.6	26.5	21.2	28.0	21.8	29.9	22.8	32.7	23.5	33.7	22.8	
	35	19.7	17.6	23.3	19.6	26.5	21.2	28.0	21.8	29.9	22.6	32.7	23.5	33.7	23.0	
	37	19.4	17.3	23.0	19.3	26.3										

7

HSP(High static pressure) duct

7-2. Capacity tables

2) Heating

TC: Total Capacity(kW)

Model	Outdoor temperature (°C, DB)		Indoor temperature (°C, DB)				
			16.0	18.0	20.0	22.0	24.0
	DB	WB	TC	TC	TC	TC	TC
112	-20	-21	7.2	6.9	6.6	6.5	6.5
	-17	-18	8.0	7.6	7.4	7.3	7.3
	-15	-16	8.4	8.1	7.9	7.7	7.5
	-12	-13	8.8	8.6	8.4	8.2	8.1
	-10	-11	9.2	9.0	8.9	8.8	8.7
	-7	-8	9.7	9.6	9.4	9.2	9.0
	-5	-6	10.2	10.1	9.9	9.6	9.3
	-3	-4	10.7	10.6	10.5	10.1	9.7
	0	-1	11.3	11.1	11.1	10.5	10.0
	3	2.2	11.8	11.6	11.5	11.0	10.6
	5	4.1	12.3	12.2	12.0	11.3	10.6
	7	6	12.9	12.7	12.5	11.5	10.6
	9	7.9	13.3	12.9	12.5	11.5	10.6
	11	9.8	13.7	13.1	12.5	11.5	10.6
	13	12	14.0	13.3	12.5	11.5	10.6
	15	14	14.4	13.5	12.5	11.5	10.6
128	-20	-21	7.9	7.7	7.3	7.2	7.2
	-17	-18	8.8	8.5	8.1	8.0	8.0
	-15	-16	9.2	9.0	8.7	8.5	8.2
	-12	-13	9.7	9.5	9.3	9.1	8.9
	-10	-11	10.1	10.0	9.9	9.7	9.6
	-7	-8	10.7	10.6	10.4	10.2	10.0
	-5	-6	11.3	11.1	11.0	10.7	10.3
	-3	-4	11.9	11.7	11.5	11.1	10.7
	0	-1	12.4	12.3	12.1	11.6	11.0
	3	2.2	13.0	12.9	12.7	12.2	11.7
	5	4.1	13.6	13.4	13.2	12.4	11.7
	7	6	14.2	14.0	13.8	12.7	11.7
	9	7.9	14.6	14.2	13.8	12.7	11.7
	11	9.8	15.1	14.4	13.8	12.7	11.7
	13	12	15.5	14.7	13.8	12.7	11.7
	15	14	15.9	14.9	13.8	12.7	11.7
140	-20	-21	9.2	8.9	8.5	8.4	8.4
	-17	-18	10.2	9.8	9.4	9.3	9.3
	-15	-16	10.7	10.4	10.1	9.8	9.5
	-12	-13	11.2	11.0	10.8	10.6	10.3
	-10	-11	11.7	11.6	11.4	11.3	11.1
	-7	-8	12.4	12.2	12.1	11.8	11.5
	-5	-6	13.1	12.9	12.7	12.3	12.0
	-3	-4	13.8	13.6	13.4	12.9	12.4
	0	-1	14.4	14.2	14.0	13.4	12.8
	3	2.2	15.1	14.9	14.7	14.1	13.5
	5	4.1	15.8	15.6	15.3	14.4	13.5
	7	6	16.5	16.2	16.0	14.8	13.5
	9	7.9	17.0	16.5	16.0	14.8	13.5
	11	9.8	17.5	16.7	16.0	14.8	13.5
	13	12	18.0	17.0	16.0	14.8	13.5
	15	14	18.5	17.2	16.0	14.8	13.5
220	-20	-21	20.3	19.5	18.4	17.5	16.8
	-17	-18	20.8	20.0	18.9	18.4	18.2
	-15	-16	21.6	20.7	19.6	19.1	18.8
	-12	-13	23.0	22.1	20.9	20.2	20.0
	-10	-11	24.7	23.7	22.4	21.4	21.1
	-7	-8	25.4	24.4	23.0	22.3	22.0
	-5	-6	26.2	25.2	23.7	23.2	22.6
	-3	-4	26.8	25.8	24.3	24.1	23.1
	0	-1	27.4	26.5	24.9	24.3	23.7
	3	2	28.0	27.0	25.0	24.4	23.6
	5	4	28.3	27.0	25.0	24.4	23.6
	7	6	28.8	27.0	25.0	24.4	23.6
	9	8	28.8	27.0	25.0	24.4	23.6
	11	10	28.8	27.0	25.0	24.4	23.6
	13	12	28.8	27.0	25.0	24.4	23.6
	15	14	28.8	27.0	25.0	24.4	23.6
280	-20	-21	25.4	24.4	23.0	21.9	21.0
	-17	-18	26.0	25.0	23.6	22.9	22.5
	-15	-16	27.0	25.9	24.5	23.8	23.3
	-12	-13	28.8	27.7	26.1	25.2	24.8
	-10	-11	30.9	29.7	28.0	26.8	26.4
	-7	-8	31.8	30.5	28.8	27.9	27.3
	-5	-6	32.7	31.5	29.7	29.0	28.1
	-3	-4	33.5	32.2	30.4	29.8	28.7
	0	-1	34.3	33.1	31.1	30.4	29.3
	3	2	35.0	33.7	31.5	30.4	29.5
	5	4	35.3	33.7	31.5	30.4	29.5
	7	6	35.7	33.7	31.5	30.4	29.5
	9	8	35.7	33.7	31.5	30.4	29.5
	11	10	35.7	33.7	31.5	30.4	29.5
	13	12	35.7	33.7	31.5	30.4	29.5
	15	14	35.7	33.7	31.5	30.4	29.5

7-3. Dimensional drawing

1) ND112/128/140HH*

Unit:mm

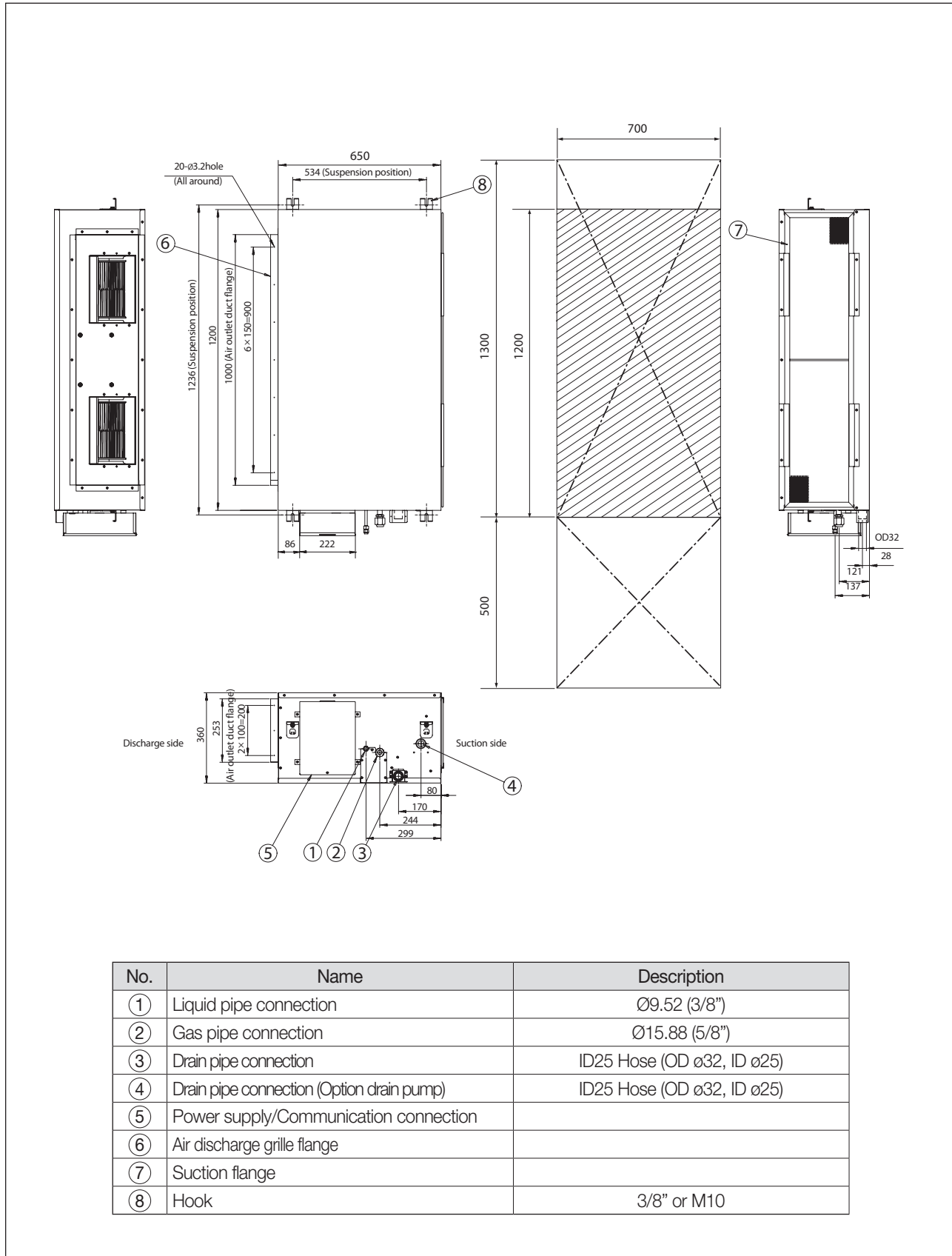

Indoor units

7 HSP(High static pressure) duct

7-3. Dimensional drawing

2) ND220/280HHXEA

Unit:mm

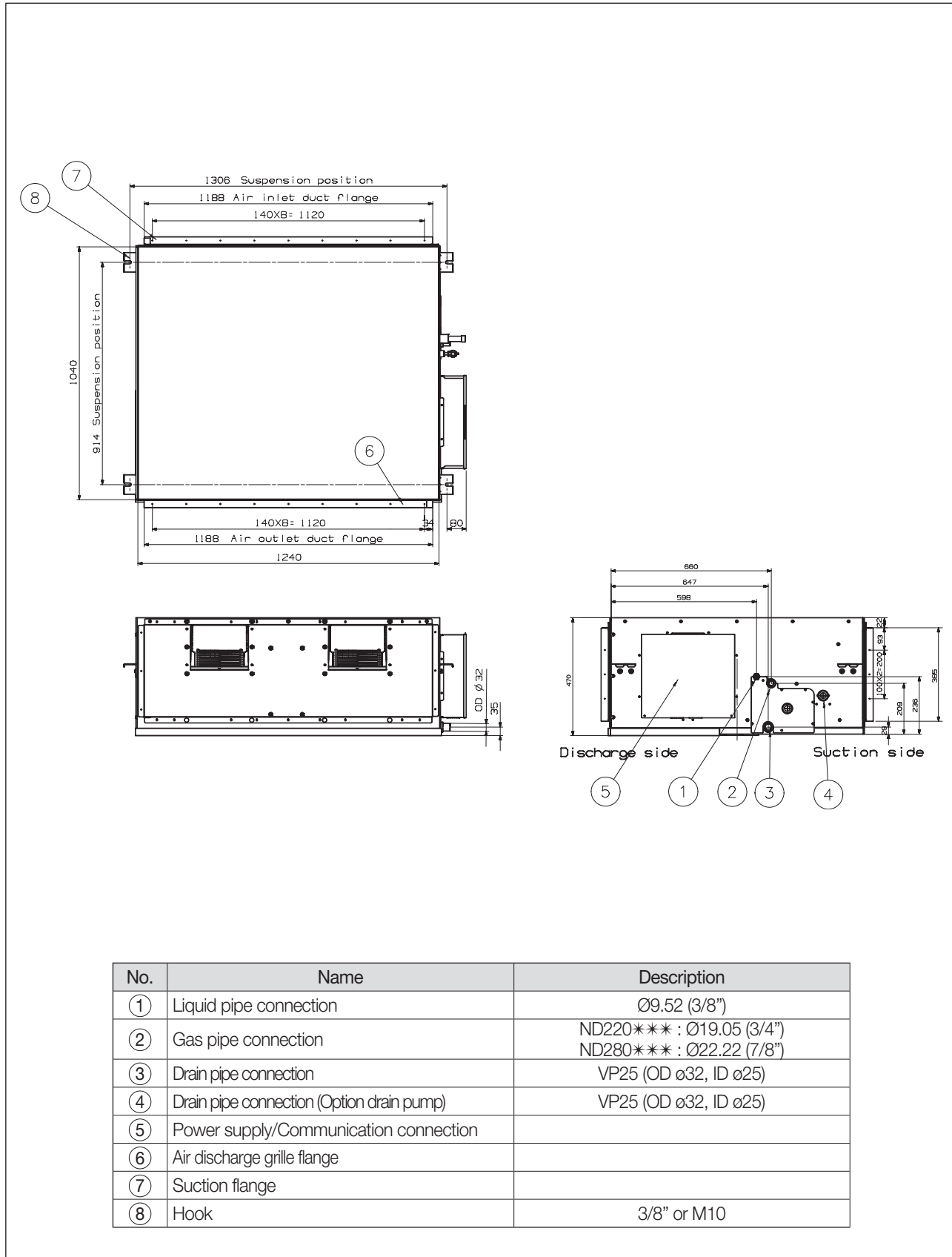

7-4. PCB connector lay-out

1) ND112/128/140HH*

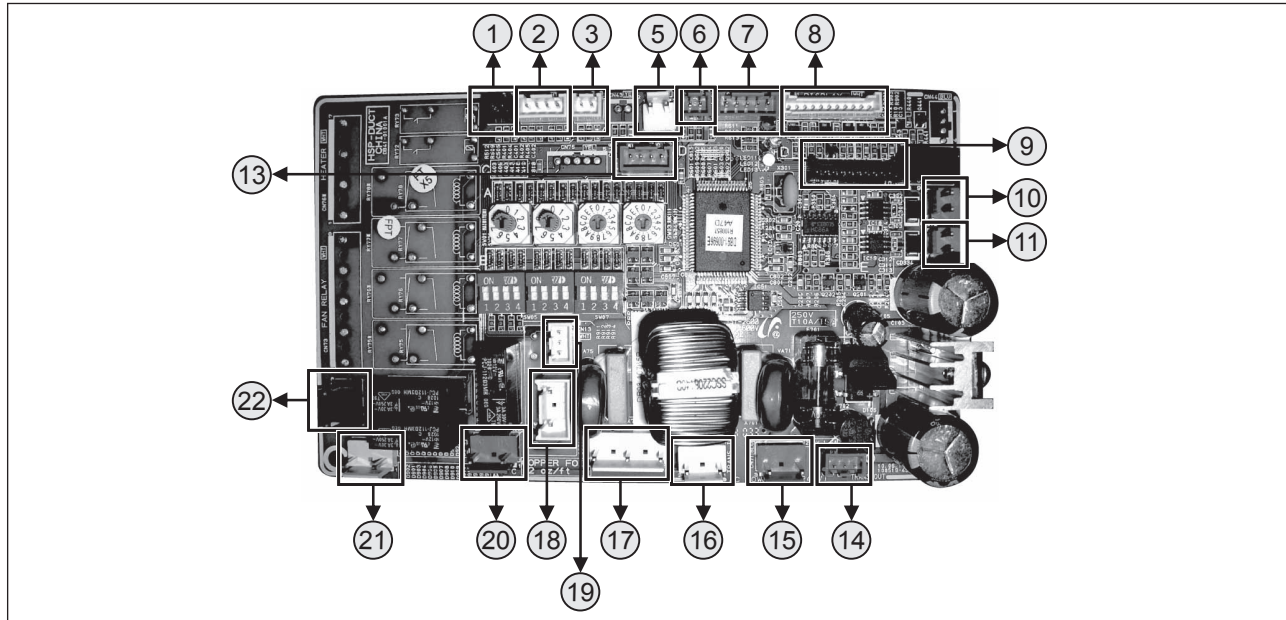

No.	CN #	COLOR	FUNCTION
①	CN51	Black	Float Switch
②	CN41	White	Room Sensor, Eva-In Sensor
③	CN42	White	EVA OUT Temp. Sensor
④			
⑤	CN32	White	DC12V for Wired Remote Controller
⑥	CN83	Red	External Control signal point input
⑦	CN62	Blue	EEV
⑧	CN91	White	Display
⑨	CN10	Black	MICOM Download
⑩	CN31	Red	Communication with Outdoor Units (COM1)
⑪	CN33	Blue	Communication with Wired Remote Controller (COM2)
⑫			
⑬	CN81	Red	Error Check, Indoor unit Operation
⑭	CN11	Red	Trans-Out (AC 17V)
⑮	CN71	Blue	AC 230V Input
⑯	CN72	White	Trans-In (AC 230V)
⑰	CN78	White	Fan Motor
⑱	CN79	White	Error Check, Indoor unit Operation
⑲	CN13	White	Drain Pump
⑳	CN77	Red	Hot Water Coil
㉑	CN74	Yellow	Drain Pump
㉒	CN75	Black	Ventilator

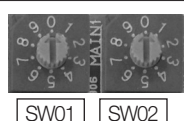
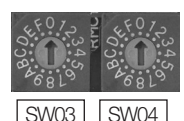
No.	S/W	FUNCTION
A	 SW01 SW02	Main Address Setting (00~63)
B	 SW03 SW04	SW03: Address of Interface Module Channel 0~2 SW04: Group Address (RMC) for Centralized Control 0~F

No.	S/W	FUNCTION	ON	OFF
C	K1	-	-	-
	K2	Centralized Controller	Not use	Use
	K3	RPM Up	N/A	N/A
	K4	Optional Drain Pump	Not use	Use
	K5	Heating Thermo-off	+2°C	+5°C
	K6	Filter Signal Display	1,000hrs	2,000hrs
	K7	Hot Water Coil	Not use	Use
	K8	Electrical Heater	N/A	N/A
	K9	Min. EEV Step at Heating	Fixed 80 step	0 or 80 step
	K10	Priority of Indoor unit Display on Wired Remote Controlle	Slave (Default)	Master
	K11	External Contact Control	Not use	Use
	K12	-	-	-

7 HSP(High static pressure) duct

7-4. PCB connector lay-out

2) ND220/280HHXEA

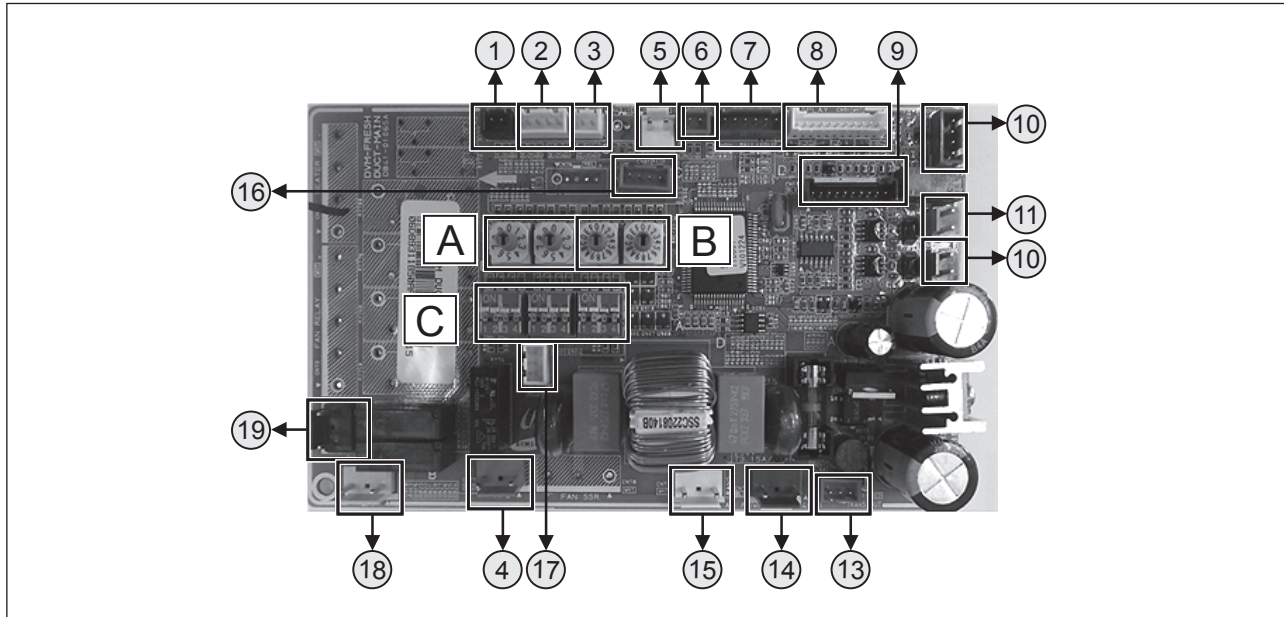

No.	CN #	COLOR	FUNCTION
①	CN51	Black	Floating Switch
②	CN41	White	Room/Eva In Temp. Sensor
③	CN42	White	Eva Out Temp. Sensor
④	CN43	Red	Hot Coil
⑤	CN32	White	Wired remote controller Power
⑥	CN83	Red	External Control
⑦	CN62	Blue	EEV
⑧	CN91	White	Display
⑨	CN10	Black	Micom Download
⑩	CN44	Blue	Motor Feedback
⑪	CN31	Red	Communication with outdoor units
⑫	CN33	Blue	Communication with wired remote controller
⑬	CN11	Red	Trans Out
⑭	CN71	Blue	AC Power
⑮	CN72	White	Trans In
⑯	CN81	Red	External CHECK
⑰	CN13	White	BLDC PCB Connector
⑱	CN74	Yellow	Drain Pump
⑲	CN75	Black	Ventilator

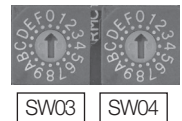
No.	S/W	FUNCTION
A		Main Address Setting (00~63)
B		SW03: Address of Interface Module Channel 0~2 SW04: Group Address (RMC) for Centralized Control 0~F

No.	S/W	FUNCTION	ON	OFF
C	K1	-	-	-
	K2	Centralized Controller	Not use	Use
	K3	RPM Up	N/A	N/A
	K4	Optional Drain Pump	Not use	Use
	K5	Heating Thermo-off	+2°C	+5°C
	K6	Filter Signal Display	1,000hrs	2,000hrs
	K7	Hot Water Coil	Not use	Use
	K8	Electrical Heater	N/A	N/A
	K9	Min. EEV Step at Heating	Fixed 80 step	0 or 80 step
	K10	Priority of Indoor unit Display on Wired Remote Control	Slave (Default)	Master
	K11	External Contact Control	Not use	Use
	K12	-	-	-

7-5. Electrical wiring diagram

1) ND112/128/140HH*

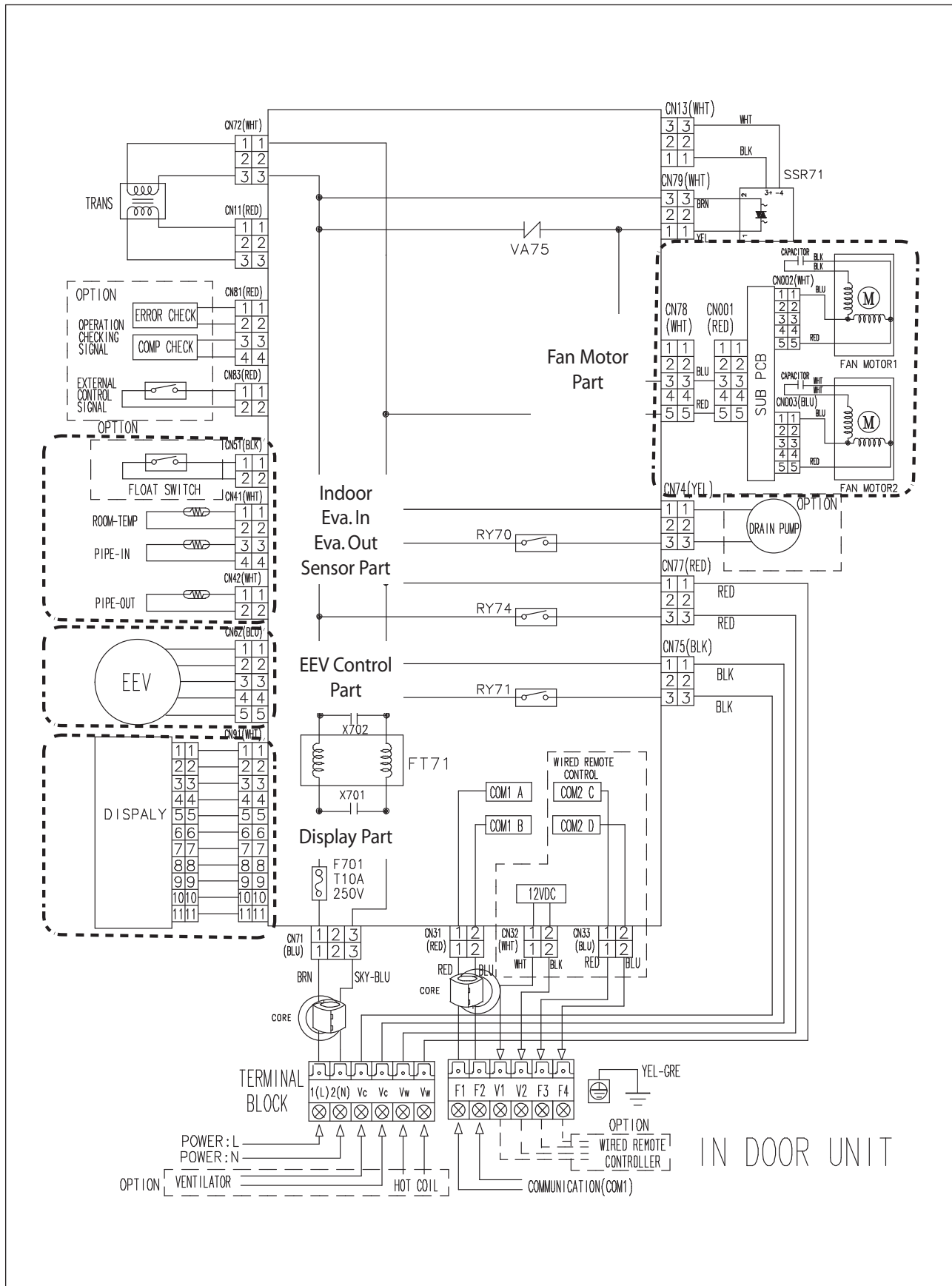

Indoor units

IN DOOR UNIT

7 HSP(High static pressure) duct

7-5. Electrical wiring diagram

2) ND220/280HHXEA

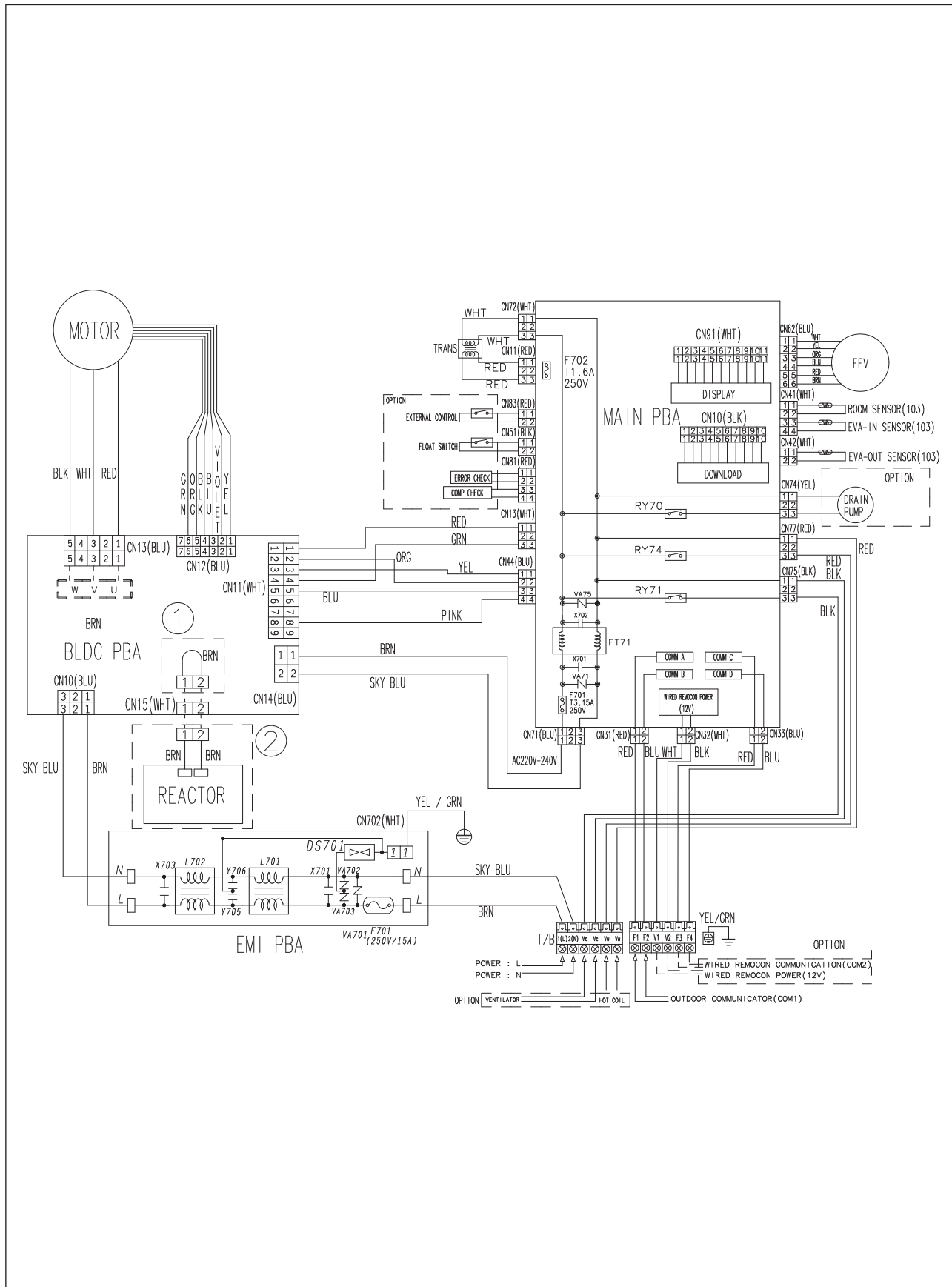

7-6. Sound pressure level

1) Operation sound level

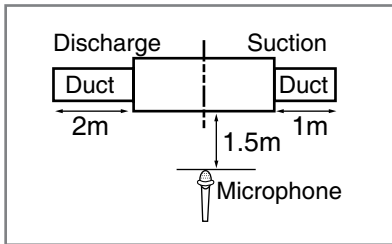

Unit : dB(A)

Model	High	Low
ND112HHXEB	43	39
ND128HHXEB	44	40
ND140HHXEB	45	41
ND220HHXEA	47	44
ND280HHXEA	48	45

Note

- ◆ These operation values were obtained in a dead room. Sound pressure level will vary depending on a range of factors such as the construction of the particular room where the equipment is installed.
- ◆ Operation sound level may differ depending on operation and ambient conditions.

2) NC curves

(1) ND112HHXEB

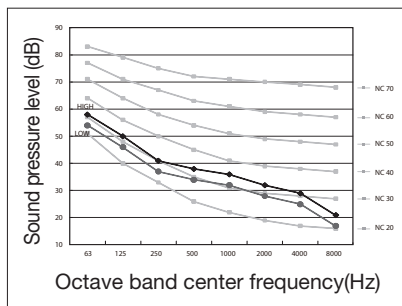

(2) ND128HHXEB

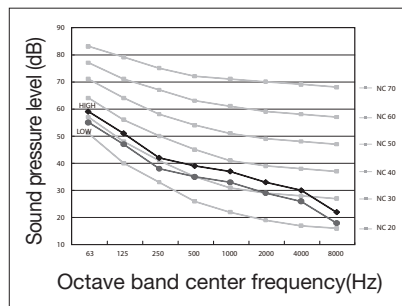

(3) ND140HHXEB

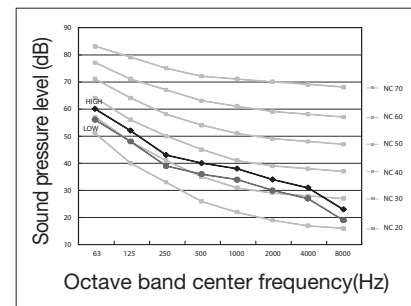

(4) ND220HHXEA

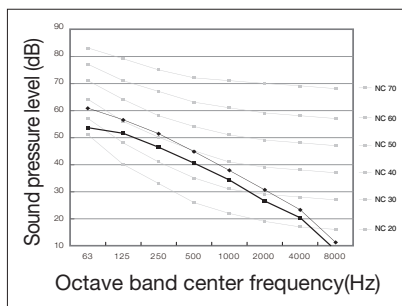

(5) ND280HHXEA

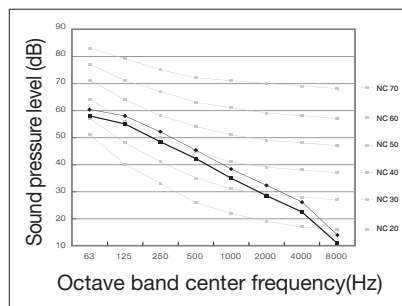

7

HSP(High static pressure) duct

7-7. Recommended operation range

(1) ND140HHXEB

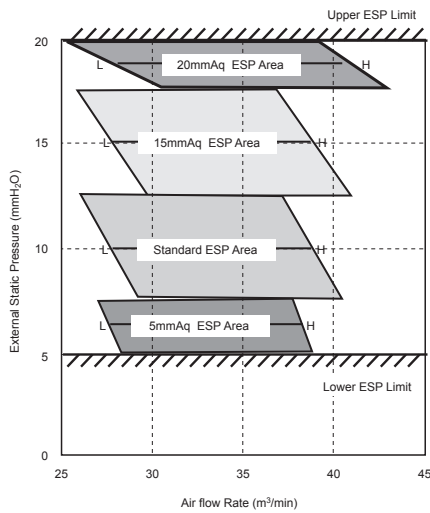

External Static pressure (mmAq)	Option code
5	015A2313019D-200000300000
10	015A231301CF-200000300000
15	015A24130223-200000300000
20	015A241302FF-200000300000

(2) ND128HHXEB

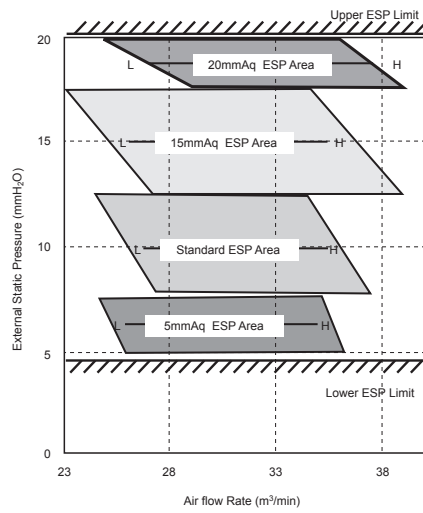

External Static pressure (mmAq)	Option code
5	015A23120159-200000300000
10	015A2312017C-200000300000
15	015A231201DF-200000300000
20	015A241202A6-200000300000

(3) ND112HHXEB

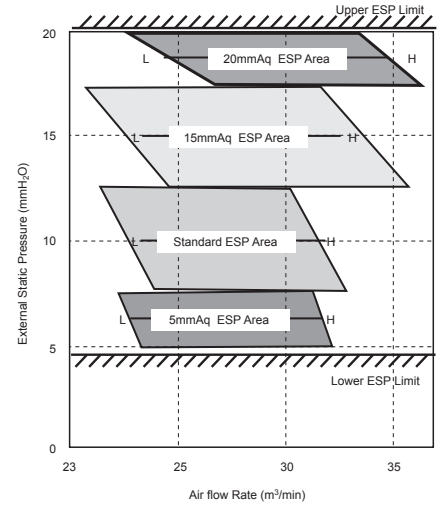

External Static pressure (mmAq)	Option code
5	015A23100117-200000300000
10	015A2310013A-200000300000
15	015A2310019D-200000300000
20	015A24100273-200000300000

(4) ND220HHXEA

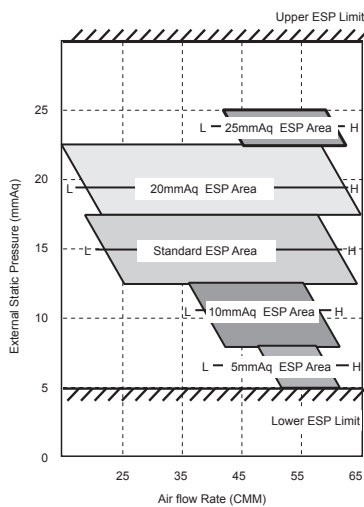

ESP (mmAq)	Option code
5	015A17160097-200000300000
10	015A171600C7-200000300000
15	015A171600E8-200000300000
20	015A1716024D-200000300000
25	015A1716029F-200000300000

(5) ND280HHXEA

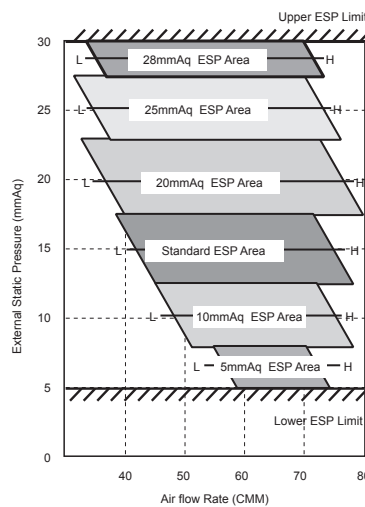

ESP (mmAq)	Option code
5	015A17170207-200000300000
10	015A17170229-200000300000
15	015A1717025B-200000300000
20	015A1717029E-200000300000
25	015A171703D1-200000300000
28	015A171703F3-200000300000

Note

- ◆ ESP = External Static Pressure
- ◆ The graphs display the available external static pressure range of installed indoor units. Therefore, they do not reflect the actual change of external static pressure and airflow rate according to adjusted airflow (High-Mid-Low) of installed indoor units.



Indoor units

8 Console (AVXTJH***E*)

8-1. Specifications.....	106
8-2. Capacity tables	107
8-3. Dimensional drawing	109
8-4. PCB connector lay-out.....	111
8-5. Electrical wiring diagram	113
8-6. Sound pressure level	114
8-7. Temperature and air flow distribution.....	115

Optional Accessories

Individual Controllers



MWR-WE10



MWR-WH00



MWR-SH00



MR-DH00

Standard Accessories

Wireless Remote Controller



8 Console

8-1. Specifications

1) Technical specifications

Model			AVXTJH028E*	AVXTJH036E*	AVXTJH056E*	
Power Supply			Ø, #, V, Hz	1, 2, 220~240, 50	1, 2, 220~240, 50	
Mode*1)			-	HP / HR	HP / HR	
Capacity (Nominal)	Cooling*2)	kW	2.8	3.6	5.6	
		Btu/h	9,600	12,300	19,100	
	Heating*3)	kW	3.2	4.0	6.3	
		Btu/h	10,900	13,600	21,500	
Power	Power Input (Nominal)	Cooling*2)	W	30	35	
		Heating*3)	W	30	35	
	Current Input (Nominal)	Cooling*2)	A	0.25	0.29	
		Heating*3)	A	0.25	0.29	
Fan	Motor	Type	-	Turbo Fan / BLDC	Turbo Fan / BLDC	
		Output	W	37	37	
		Number of unit	EA	1	1	
	Air Flow Rate	H/M/L (UL)	CMM	7 / 6 / 5	8.5 / 7.5 / 6.5	13 / 11.5 / 10
			CFM	250 / 210 / 180	300 / 260 / 230	460 / 410 / 350
	External Pressure	Min / Std / Max	mmAq	-	-	-
			Pa	-	-	-
			WG	-	-	-
Option Code			-	085617-1300C8-200000-300000	085617-1500E8-200000-300000	
Piping Connections	Liquid Pipe	Ø, mm	6.35	6.35	6.35	
		Ø, inch	1/4	1/4	1/4	
	Gas Pipe	Ø, mm	12.7	12.7	12.7	
		Ø, inch	1/2	1/2	1/2	
	Drain Pipe	Ø, mm	ID18 Hose (OD, ID)	ID18 Hose (OD, ID)	ID18 Hose (OD, ID)	
Field Wiring	Power Source Wire	Below 20m / over 20m	mm ²	1.5 / 2.5	1.5 / 2.5	
	Transmission Cable		mm ²	0.75 / 1.5	0.75 / 1.5	
Refrigerant	Type	-	R410A	R410A	R410A	
	Control Method	-	EEV	EEV	EEV	
Sound	Sound Pressure	High / Low*4)	dBA	38 / 23	39 / 24	
Dimensions	Net Weight		kg	15	15	
	Shipping Weight		kg	20	20	
	Net Dimensions (W×H×D)		mm	720 x 620 x 199	720 x 620 x 199	
	Shipping Dimensions (W×H×D)		mm	810 x 710 x 295	810 x 710 x 295	
Panel Size	Panel model		-	-	-	
	Panel Net Weight		kg	-	-	
	Shipping Weight		kg	-	-	
	Net Dimensions (W×H×D)		mm	-	-	
	Shipping Dimensions (W×H×D)		mm	-	-	
Additional Accessories	Drain pump	Drain pump	- / Model	-	-	
		Max. lifting Height / Displacement	mm/liter/h	-	-	
	Air Filter		-	Long life filter	Long life filter	

* Specifications may be subject to change without prior notice for product improvement.

*1) Mode

- HP : Heat Pump, HR : Heat Recovery

*2) Nominal cooling capacities are based on;

- Indoor temperature : 27°C DB, 19°C WB

- Outdoor temperature : 35°C DB, 24°C WB, Equivalent refrigerant piping : 7.5m, Level differences : 0m

*3) Nominal heating capacities are based on;

- Indoor temperature : 20°C DB, 15°C WB

- Outdoor temperature : 7°C DB, 6°C WB, Equivalent refrigerant piping : 7.5m, Level differences : 0m

*4) Sound pressure was acquired in a dead room. Thus actual noise level may be different depending on the installation conditions.

8-2. Capacity tables

1) Cooling

TC : Total Capacity(kW), SHC : Sensible Heat Capacity(kW)

Model	Outdoor temperature (°C, DB)	Indoor temperature (°C, WB)													
		20 (°C, DB) 14 (°C, WB)		23 (°C, DB) 16 (°C, WB)		26 (°C, DB) 18 (°C, WB)		27 (°C, DB) 19 (°C, WB)		28 (°C, DB) 20 (°C, WB)		30 (°C, DB) 22 (°C, WB)		32 (°C, DB) 24 (°C, WB)	
		TC	SHC	TC	SHC	TC	SHC	TC	SHC	TC	SHC	TC	SHC	TC	SHC
028	10	1.9	1.7	2.3	2.0	2.6	2.0	2.8	2.2	2.9	2.2	3.1	2.2	3.4	2.1
	12	1.9	1.7	2.3	2.0	2.6	2.0	2.8	2.2	2.9	2.2	3.1	2.2	3.3	2.0
	14	1.9	1.7	2.3	2.0	2.6	2.0	2.8	2.2	2.9	2.2	3.1	2.2	3.3	2.0
	16	1.9	1.7	2.3	2.0	2.6	2.0	2.8	2.2	2.9	2.2	3.1	2.2	3.3	2.0
	18	1.9	1.7	2.3	2.0	2.6	2.0	2.8	2.2	2.9	2.2	3.1	2.2	3.3	2.0
	20	1.9	1.7	2.3	2.0	2.6	2.0	2.8	2.2	2.9	2.2	3.1	2.2	3.3	2.0
	21	1.9	1.7	2.3	2.0	2.6	2.0	2.8	2.2	2.9	2.2	3.1	2.2	3.3	2.0
	23	1.9	1.7	2.3	2.0	2.6	2.0	2.8	2.2	2.9	2.2	3.1	2.2	3.3	2.0
	25	1.9	1.7	2.3	2.0	2.6	2.0	2.8	2.2	2.9	2.2	3.1	2.2	3.3	2.0
	27	1.9	1.7	2.3	2.0	2.6	2.0	2.8	2.2	2.9	2.2	3.1	2.2	3.3	2.0
	29	1.9	1.7	2.3	2.0	2.6	2.0	2.8	2.2	2.9	2.2	3.1	2.2	3.3	2.0
	31	1.9	1.7	2.3	2.0	2.6	2.0	2.8	2.2	2.9	2.2	3.1	2.2	3.3	2.0
	33	1.9	1.7	2.3	2.0	2.6	2.0	2.8	2.2	2.9	2.2	3.1	2.2	3.3	2.0
	35	1.9	1.7	2.3	2.0	2.6	2.0	2.8	2.2	2.9	2.2	3.1	2.2	3.3	2.0
	37	1.9	1.7	2.3	2.0	2.6	2.0	2.8	2.2	2.9	2.2	3.1	2.2	3.3	2.0
39	1.9	1.7	2.3	2.0	2.6	2.0	2.8	2.2	2.9	2.2	3.0	2.1	3.2	1.9	
42	1.9	1.7	2.3	2.0	2.6	2.0	2.7	2.1	2.8	2.1	2.9	2.0	3.0	1.8	
44	1.9	1.7	2.3	2.0	2.5	1.9	2.7	2.1	2.7	2.0	2.7	1.9	2.8	1.7	
036	10	2.5	2.0	2.9	2.3	3.4	2.4	3.6	2.5	3.7	2.5	4.0	2.5	4.3	2.4
	12	2.5	2.0	2.9	2.3	3.4	2.4	3.6	2.5	3.7	2.5	4.0	2.5	4.3	2.4
	14	2.5	2.0	2.9	2.3	3.4	2.4	3.6	2.5	3.7	2.5	4.0	2.5	4.3	2.4
	16	2.5	2.0	2.9	2.3	3.4	2.4	3.6	2.5	3.7	2.5	4.0	2.5	4.3	2.4
	18	2.5	2.0	2.9	2.3	3.4	2.4	3.6	2.5	3.7	2.5	4.0	2.5	4.3	2.4
	20	2.5	2.0	2.9	2.3	3.4	2.4	3.6	2.5	3.7	2.5	4.0	2.5	4.2	2.3
	21	2.5	2.0	2.9	2.3	3.4	2.4	3.6	2.5	3.7	2.5	4.0	2.5	4.2	2.3
	23	2.5	2.0	2.9	2.3	3.4	2.4	3.6	2.5	3.7	2.5	4.0	2.5	4.2	2.3
	25	2.5	2.0	2.9	2.3	3.4	2.4	3.6	2.5	3.7	2.5	4.0	2.5	4.2	2.3
	27	2.5	2.0	2.9	2.3	3.4	2.4	3.6	2.5	3.7	2.5	4.0	2.5	4.2	2.3
	29	2.5	2.0	2.9	2.3	3.4	2.4	3.6	2.5	3.7	2.5	4.0	2.5	4.2	2.3
	31	2.5	2.0	2.9	2.3	3.4	2.4	3.6	2.5	3.7	2.5	4.0	2.5	4.2	2.3
	33	2.5	2.0	2.9	2.3	3.4	2.4	3.6	2.5	3.7	2.5	4.0	2.5	4.2	2.3
	35	2.5	2.0	2.9	2.3	3.4	2.4	3.6	2.5	3.7	2.5	4.0	2.5	4.2	2.3
	37	2.5	2.0	2.9	2.3	3.4	2.4	3.6	2.5	3.7	2.5	3.9	2.4	4.2	2.3
39	2.5	2.0	2.9	2.3	3.4	2.4	3.6	2.5	3.7	2.5	3.9	2.4	4.1	2.2	
42	2.5	2.0	2.9	2.3	3.4	2.4	3.5	2.4	3.6	2.4	3.7	2.3	3.9	2.1	
44	2.5	2.0	2.9	2.3	3.2	2.3	3.4	2.3	3.5	2.3	3.5	2.2	3.7	2.0	
056	10	3.1	3.0	4.5	3.5	5.3	3.6	5.6	3.8	5.8	3.8	6.2	3.8	6.7	3.6
	12	3.1	3.0	4.5	3.5	5.3	3.6	5.6	3.8	5.8	3.8	6.2	3.8	6.7	3.6
	14	3.1	3.0	4.5	3.5	5.3	3.6	5.6	3.8	5.8	3.8	6.2	3.8	6.7	3.6
	16	3.1	3.0	4.5	3.5	5.3	3.6	5.6	3.8	5.8	3.8	6.2	3.8	6.7	3.6
	18	3.1	3.0	4.5	3.5	5.3	3.6	5.6	3.8	5.8	3.8	6.2	3.8	6.7	3.6
	20	3.1	3.0	4.5	3.5	5.3	3.6	5.6	3.8	5.8	3.8	6.2	3.8	6.5	3.5
	21	3.1	3.0	4.5	3.5	5.3	3.6	5.6	3.8	5.8	3.8	6.2	3.8	6.5	3.5
	23	3.1	3.0	4.5	3.5	5.3	3.6	5.6	3.8	5.8	3.8	6.2	3.8	6.5	3.5
	25	3.1	3.0	4.5	3.5	5.3	3.6	5.6	3.8	5.8	3.8	6.2	3.8	6.5	3.5
	27	3.1	3.0	4.5	3.5	5.3	3.6	5.6	3.8	5.8	3.8	6.2	3.8	6.5	3.5
	29	3.1	3.0	4.5	3.5	5.3	3.6	5.6	3.8	5.8	3.8	6.2	3.8	6.5	3.5
	31	3.1	3.0	4.5	3.5	5.3	3.6	5.6	3.8	5.8	3.8	6.2	3.8	6.5	3.5
	33	3.1	3.0	4.5	3.5	5.3	3.6	5.6	3.8	5.8	3.8	6.2	3.8	6.5	3.5
	35	3.1	3.0	4.5	3.5	5.3	3.6	5.6	3.8	5.8	3.8	6.2	3.8	6.5	3.5
	37	3.1	3.0	4.5	3.5	5.3	3.6	5.6	3.8	5.8	3.8	6.1	3.6	6.5	3.5
39	3.1	3.0	4.5	3.5	5.3	3.6	5.6	3.8	5.8	3.8	6.1	3.6	6.4	3.3	
42	3.1	3.0	4.5	3.5	5.3	3.6	5.4	3.6	5.6	3.6	5.8	3.5	6.1	3.2	
44	3.1	3.0	4.5	3.5	5.0	3.5	5.3	3.5	5.4	3.5	5.4	3.3	5.8	3.0	

Indoor units

8 Console

8-2. Capacity tables

2) Heating

TC : Total Capacity(kW)

Model	Outdoor temperature (°C)		Indoor temperature (°C, DB)				
			16.0	18.0	20.0	22.0	24.0
	DB	WB	TC kW	TC kW	TC kW	TC kW	TC kW
028	-20	-21	1.9	1.9	1.9	1.9	1.9
	-17	-18	2.0	2.0	2.0	2.0	1.9
	-15	-16	2.1	2.1	2.0	2.0	1.9
	-12	-13	2.2	2.2	2.2	2.1	2.1
	-10	-11	2.3	2.3	2.3	2.3	2.2
	-7	-8	2.5	2.4	2.4	2.4	2.3
	-5	-6	2.6	2.6	2.5	2.5	2.4
	-3	-4	2.8	2.7	2.7	2.6	2.5
	0	-1	2.9	2.8	2.8	2.7	2.6
	3	2.2	3.0	3.0	2.9	2.8	2.7
	5	4.1	3.2	3.1	3.1	2.9	2.7
	7	6	3.3	3.2	3.2	3.0	2.7
	9	7.9	3.4	3.3	3.2	3.0	2.7
	11	9.8	3.5	3.3	3.2	3.0	2.7
	13	12	3.6	3.4	3.2	3.0	2.7
15	14	3.7	3.4	3.2	3.0	2.7	
036	-20	-21	2.4	2.4	2.3	2.3	2.3
	-17	-18	2.6	2.5	2.4	2.4	2.3
	-15	-16	2.7	2.6	2.5	2.5	2.4
	-12	-13	2.8	2.7	2.7	2.6	2.6
	-10	-11	2.9	2.9	2.9	2.8	2.8
	-7	-8	3.1	3.1	3.0	3.0	2.9
	-5	-6	3.3	3.2	3.2	3.1	3.0
	-3	-4	3.4	3.4	3.3	3.2	3.1
	0	-1	3.6	3.6	3.5	3.4	3.2
	3	2.2	3.8	3.7	3.7	3.5	3.4
	5	4.1	3.9	3.9	3.8	3.6	3.4
	7	6	4.1	4.1	4.0	3.7	3.4
	9	7.9	4.2	4.1	4.0	3.7	3.4
	11	9.8	4.4	4.2	4.0	3.7	3.4
	13	12	4.5	4.2	4.0	3.7	3.4
15	14	4.6	4.3	4.0	3.7	3.4	
056	-20	-21	3.8	3.8	3.6	3.6	3.6
	-17	-18	4.1	3.9	3.8	3.8	3.6
	-15	-16	4.3	4.1	3.9	3.9	3.8
	-12	-13	4.4	4.3	4.3	4.1	4.1
	-10	-11	4.6	4.6	4.6	4.4	4.4
	-7	-8	4.9	4.9	4.7	4.7	4.6
	-5	-6	5.2	5.0	5.0	4.9	4.7
	-3	-4	5.4	5.4	5.2	5.0	4.9
	0	-1	5.7	5.7	5.5	5.4	5.0
	3	2.2	6.0	5.8	5.8	5.5	5.4
	5	4.1	6.1	6.1	6.0	5.7	5.4
	7	6	6.5	6.5	6.3	5.8	5.4
	9	7.9	6.6	6.5	6.3	5.8	5.4
	11	9.8	6.9	6.6	6.3	5.8	5.4
	13	12	7.1	6.6	6.3	5.8	5.4
15	14	7.2	6.8	6.3	5.8	5.4	

8-3. Dimensional drawing

1) AVXTJH028/036E*

Unit:mm

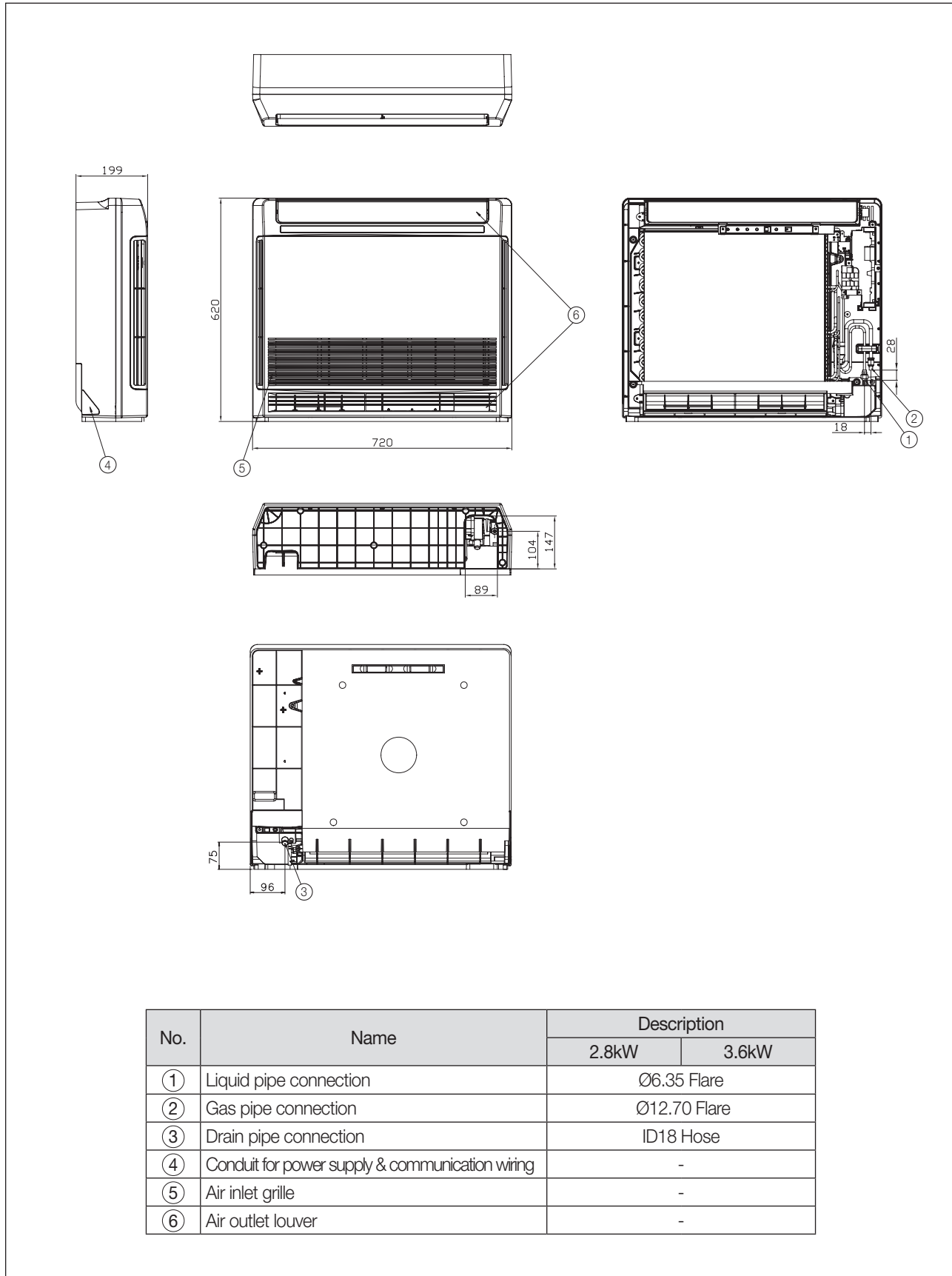

Indoor units

8 Console

8-3. Dimensional drawing

2) AVXTJH056E*

Unit:mm

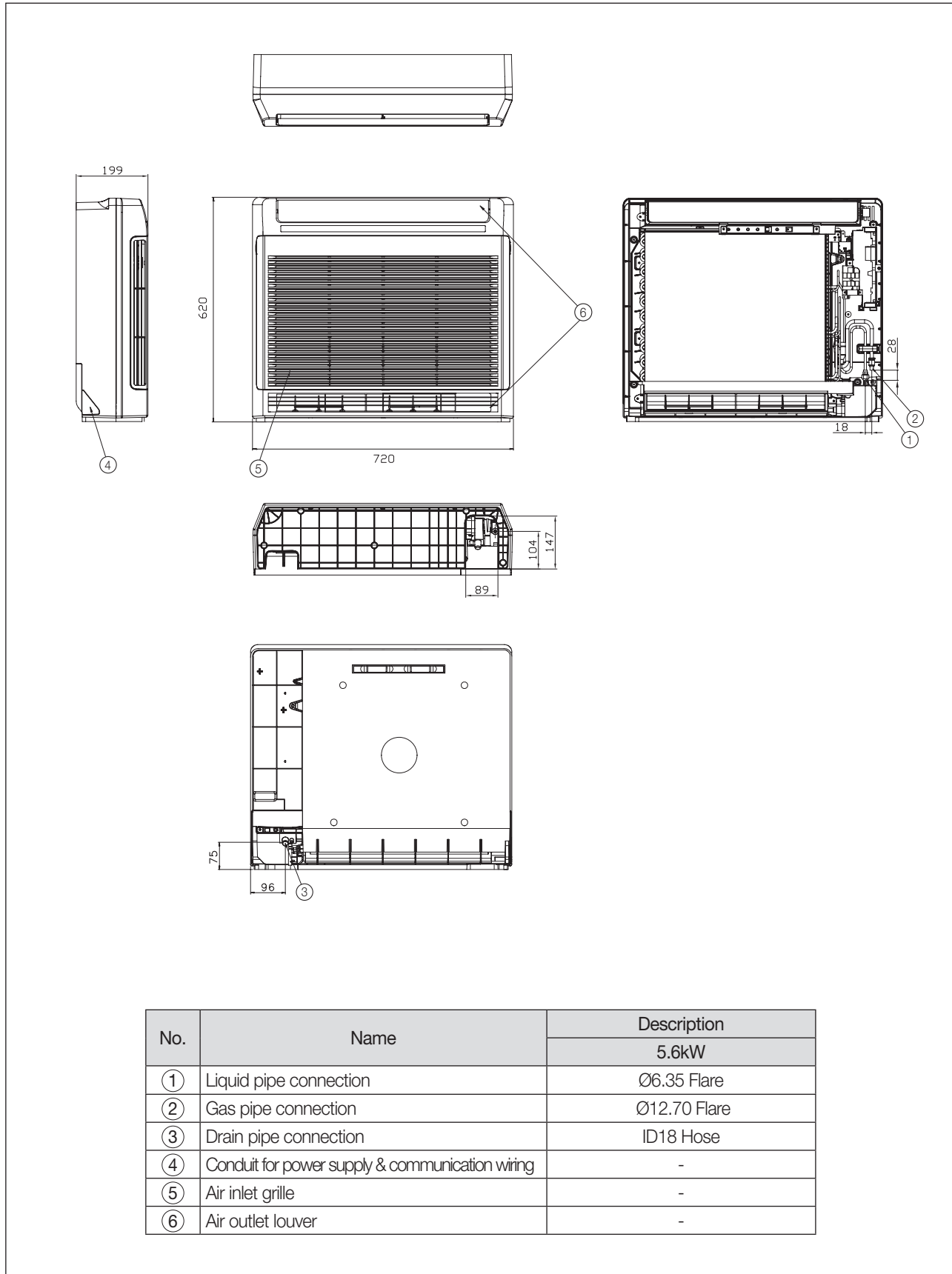

8-4. PCB connector lay-out

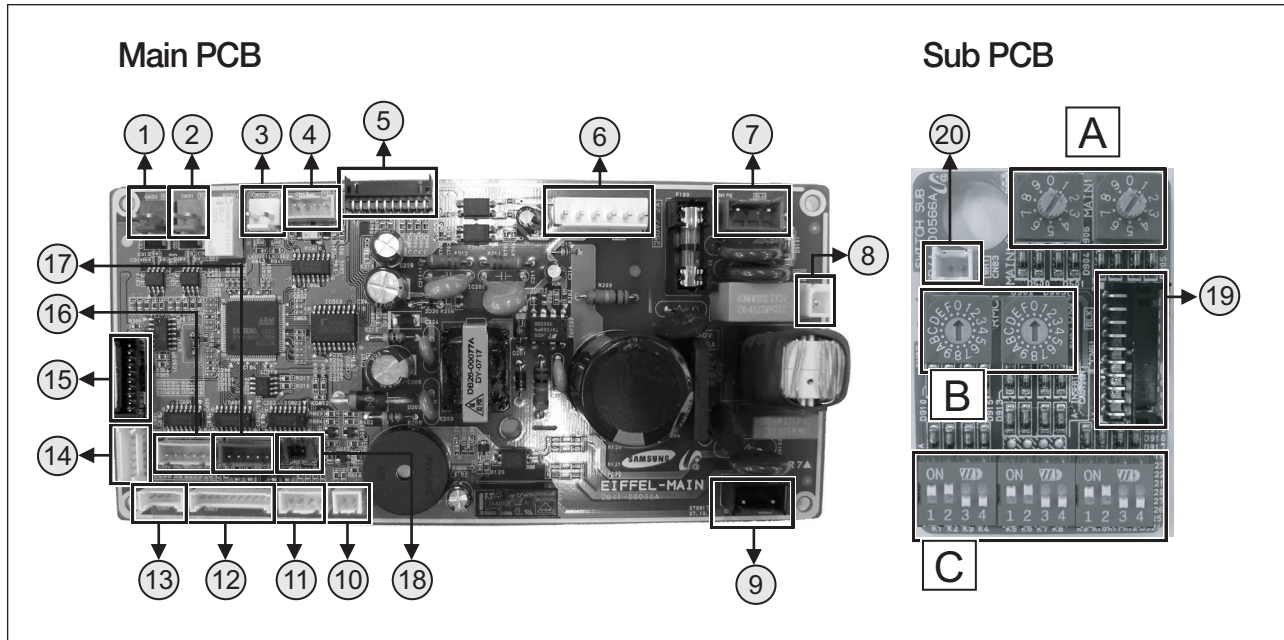

Indoor units

Main PCB			
No.	CN #	COLOR	FUNCTION
①	CN33	Blue	Communication with Wired Remote Controller (COM2)
②	CN31	Red	Communication with Outdoor Units (COM1)
③	CN32	White	DC12V for Wired Remote Controller
④	CN45	Yellow	MPI
⑤	CN86	Black	Main-Sub PCB connector
⑥	CN73	White	Fan Motor
⑦	CN100	Blue	AC 230V Input
⑧	CN70	White	Earth
⑨	CN75	Black	Ventilator
⑩	CN42	White	Eva-Out Sensor
⑪	CN41	White	Room Sensor, Eva-In Sensor
⑫	CN83	White	Main-Display PCB connector
⑬	CN81	White	Louver Motor
⑭	CN20	White	MICOM Download 2
⑮	CN10	Black	MICOM Download 1
⑯	CN82	Yellow	Damper Motor
⑰	CN85	Blue	EEV
⑱	CN87	Blue	Main-Damper PCB connector

Sub PCB			
No.	CN #	COLOR	FUNCTION
⑱	CN61	Black	Main-Sub PCB connector
⑳	CN83	White	External Contact Control

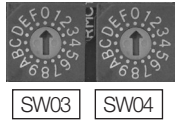
No.	S/W	FUNCTION	
A		Main Address (00-63)	
B		SW03	SW04
		Address of Interface Module Channel 0-2	Group Address (RMC) for Centralized Control 0-F

No.	S/W	FUNCTION	ON	OFF
	K1	-	-	-
	K2	Centralized Controller	Not use	Use
	K3	RPM Up	N/A	N/A
	K4	Optional Drain Pump	N/A	N/A
	K5	Heating Thermo-off	+2°C	+5°C
	K6	Filter Signal Display	1,000hrs	2,000hrs
	K7	Hot Water Coil	N/A	N/A
	K8	Electrical Heater	N/A	N/A
	K9	Min. EEV Step at Heating	Fixed 80 step	0 or 80 step
	K10	Priority of Indoor unit Display on Wired Remote Controlle	Slave (Default)	Master
	K11	External Contact Control	Not use	Use
	K12	-	-	-

8 Console

8-4. PCB connector lay-out



Damper PCB			
No.	CN #	COLOR	FUNCTION
21	CN01	White	Damper Switch

Display PCB			
No.	CN #	COLOR	FUNCTION
22	CN01	White	Panel Display

8-5. Electrical wiring diagram

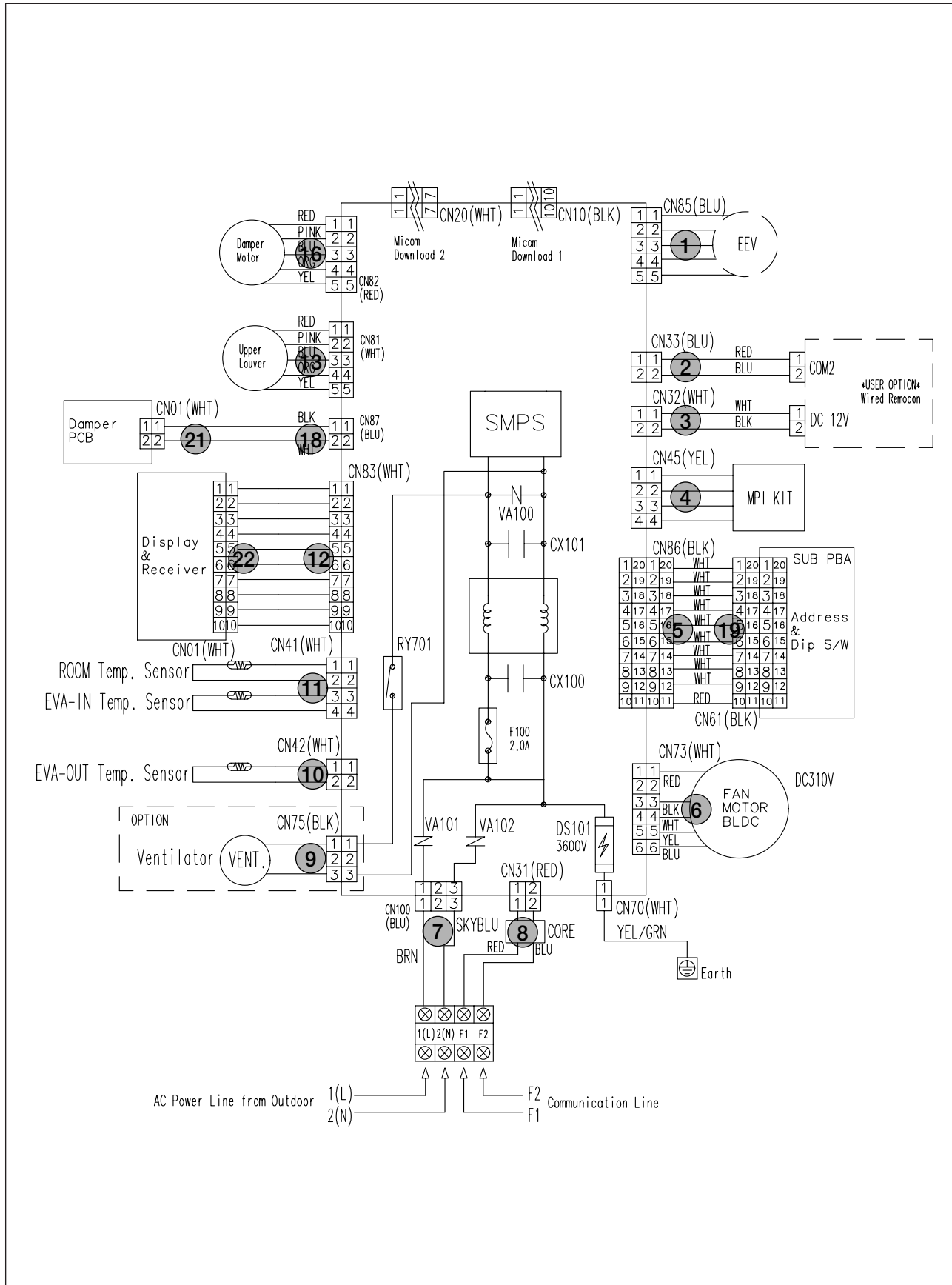

Indoor units

8 Console

8-6. Sound pressure level

1) Operation sound level

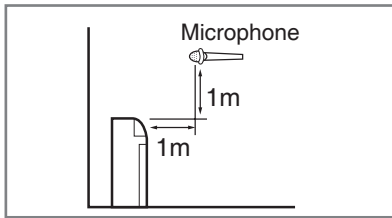

Unit : dB(A)

Model	High	Low
AVXTJH028E*	38	23
AVXTJH036E*	38	23
AVXTJH056E*	44	25

Note

- ◆ These operation values were obtained in a dead room. Sound pressure level will vary depending on a range of factors such as the construction of the particular room where the equipment is installed.
- ◆ Operation sound level may differ depending on operation and ambient conditions.

2) NC curves

(1) AVXTJH028E*

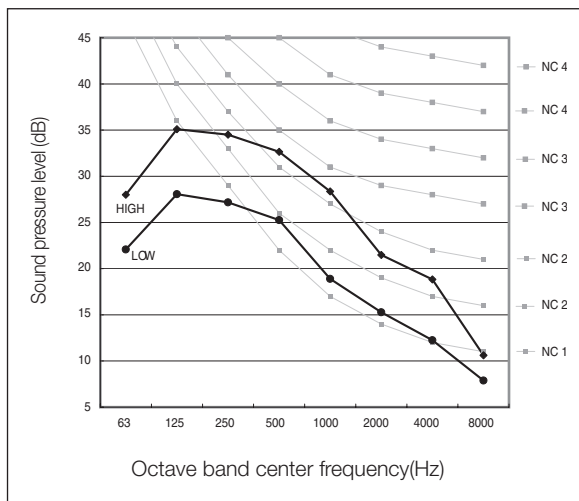

(2) AVXTJH056E*

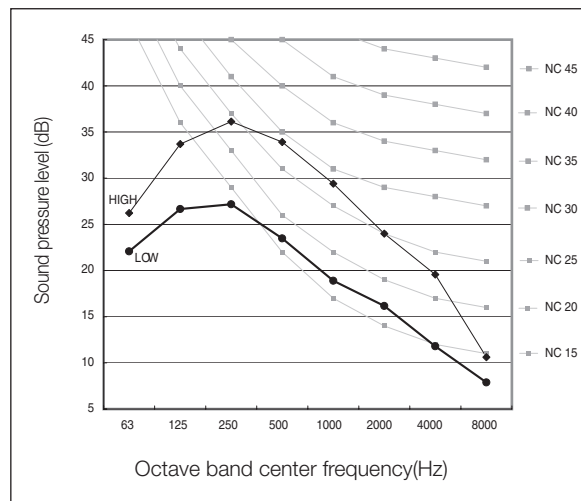

8-7. Temperature and air flow distribution

1) AVXTJH036E*

(1) Cooling air velocity distribution

◆ Discharge angle : 36°

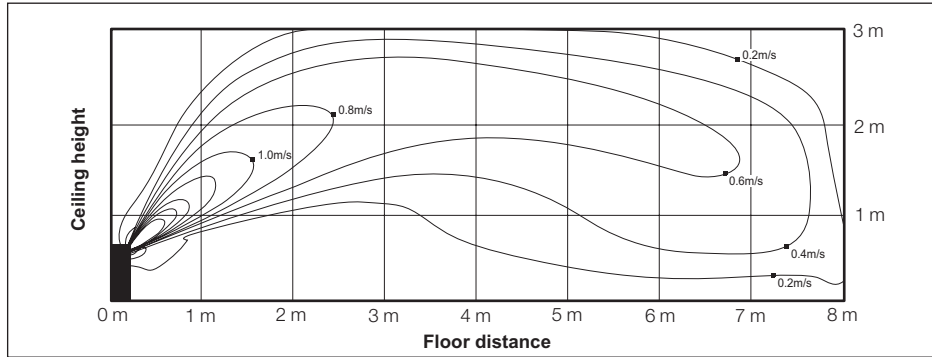

(2) Cooling temperature distribution

◆ Discharge angle : 36°

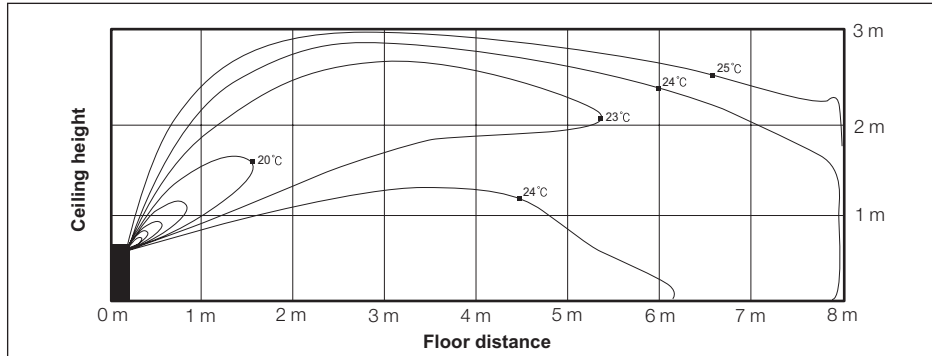

(3) Heating air velocity distribution

◆ Discharge angle : 54°

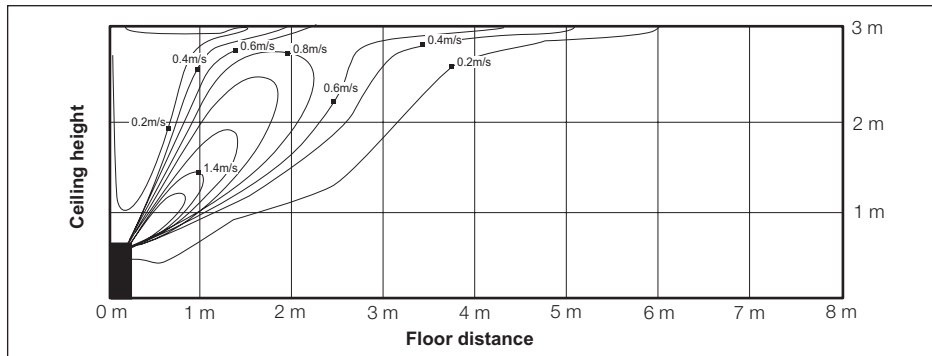

(4) Heating temperature distribution

◆ Discharge angle : 54°

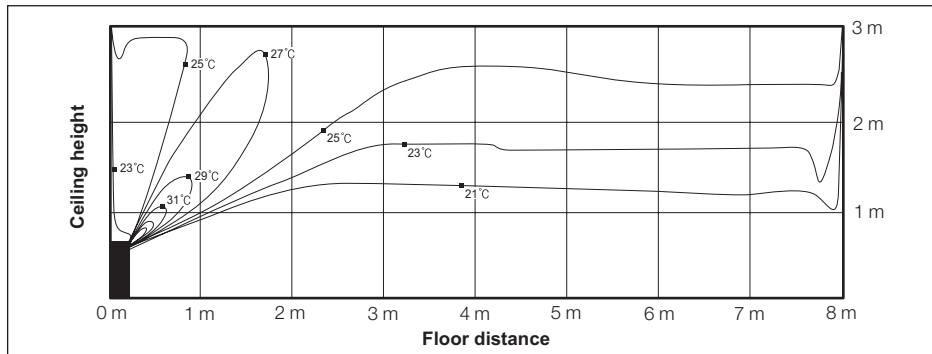



INDOOR UNIT

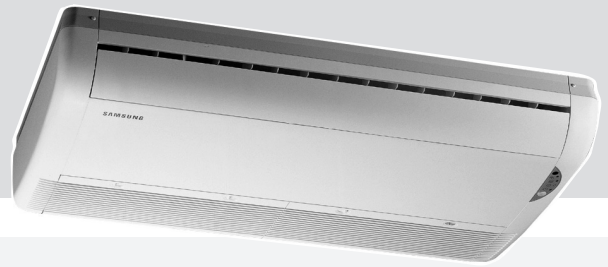

9 Ceiling (AVXTFH***E*)

9-1. Specifications.....	118
9-2. Capacity tables	119
9-3. Dimensional drawing	120
9-4. PCB connector lay-out.....	121
9-5. Electrical wiring diagram	122
9-6. Sound pressure level	123
9-7. Temperature and air flow distribution.....	124

Optional Accessories

Individual Controllers



MWR-WE10



MWR-WH00



MWR-SH00



MR-DH00

Standard Accessories

Wireless Remote Controller



9 Ceiling

9-1. Specifications

1) Technical specifications

Model				AVXTFH056E*	AVXTFH071E*	
Power Supply			Ø, #, V, Hz	1, 2, 220~240, 50	1, 2, 220~240, 50	
Mode*1)			-	HP / HR	HP / HR	
Capacity (Nominal)	Cooling*2)		kW	5.6	7.1	
			Btu/h	19,100	24,200	
	Heating*3)		kW	6.3	8.0	
			Btu/h	21,500	27,300	
Power	Power Input (Nominal)	Cooling*2)	W	72	80	
		Heating*3)	W	72	80	
	Current Input (Nominal)	Cooling*2)	A	0.33	0.35	
		Heating*3)	A	0.33	0.35	
Fan	Motor	Type	-	Sirocco Fan / AC	Sirocco Fan / AC	
		Output	W	47	47	
		Number of unit	EA	1	1	
	Air Flow Rate	H/M/L (UL)	CMM		14 / 13 / 12	18 / 16.5 / 15
			CFM		490 / 460 / 420	640 / 580 / 530
	External Pressure	Min / Std / Max	mmAq		-	-
			Pa		-	-
			WG		-	-
Option Code			-	035200-194000-200000-300000	035200-1D4000-200000-300000	
Piping Connections	Liquid Pipe	Ø, mm		6.35	9.52	
		Ø, inch		1/4	3/8	
	Gas Pipe	Ø, mm		12.7	15.88	
		Ø, inch		1/2	5/8	
	Drain Pipe	Ø, mm		ID18 Hose (OD, ID)	ID18 Hose (OD, ID)	
Field Wiring	Power Source Wire	Below 20m / over 20m	mm ²	1.5 / 2.5	1.5 / 2.5	
	Transmission Cable		mm ²	0.75 / 1.5	0.75 / 1.5	
Refrigerant	Type		-	R410A	R410A	
	Control Method		-	EEV (External)	EEV (External)	
Sound	Sound Pressure	High / Low*4)	dBA	38 / 32	41 / 36	
Dimensions	Net Weight		kg	22	22	
	Shipping Weight		kg	26	26	
	Net Dimensions (W×H×D)		mm	1,000 x 650 x 200	1,000 x 650 x 200	
	Shipping Dimensions (W×H×D)		mm	1,074 x 726 x 294	1,074 x 726 x 294	
Panel Size	Panel model		-	-	-	
	Panel Net Weight		kg	-	-	
	Shipping Weight		kg	-	-	
	Net Dimensions (W×H×D)		mm	-	-	
	Shipping Dimensions (W×H×D)		mm	-	-	
Additional Accessories	Drain pump	Drain pump	- / Model	-	-	
		Max. lifting Height / Displacement	mm/liter/h	-	-	
	Air Filter		-		Long life filter	Long life filter

* Specifications may be subject to change without prior notice for product improvement.

*1) Mode

- HP : Heat Pump, HR : Heat Recovery

*2) Nominal cooling capacities are based on;

- Indoor temperature : 27°C DB, 19°C WB

- Outdoor temperature : 35°C DB, 24°C WB, Equivalent refrigerant piping : 7.5m, Level differences : 0m

*3) Nominal heating capacities are based on;

- Indoor temperature : 20°C DB, 15°C WB

- Outdoor temperature : 7°C DB, 6°C WB, Equivalent refrigerant piping : 7.5m, Level differences : 0m

*4) Sound pressure was acquired in a dead room. Thus actual noise level may be different depending on the installation conditions.

9-2. Capacity tables

1) Cooling

TC : Total Capacity(kW), SHC : Sensible Heat Capacity(kW)

Model	Outdoor temperature (°C, DB)	Indoor temperature (°C, WB)													
		20 (°C, DB) 14 (°C, WB)		23 (°C, DB) 16 (°C, WB)		26 (°C, DB) 18 (°C, WB)		27 (°C, DB) 19 (°C, WB)		28 (°C, DB) 20 (°C, WB)		30 (°C, DB) 22 (°C, WB)		32 (°C, DB) 24 (°C, WB)	
		TC	SHC	TC	SHC	TC	SHC	TC	SHC	TC	SHC	TC	SHC	TC	SHC
056	10	3.9	3.2	4.6	3.5	5.3	3.7	5.6	3.8	5.8	3.8	6.3	3.8	6.7	3.7
	12	3.9	3.2	4.6	3.5	5.3	3.7	5.6	3.8	5.8	3.8	6.3	3.8	6.7	3.7
	14	3.9	3.2	4.6	3.5	5.3	3.7	5.6	3.8	5.8	3.8	6.2	3.8	6.7	3.7
	16	3.9	3.2	4.6	3.5	5.3	3.7	5.6	3.8	5.8	3.8	6.2	3.8	6.6	3.6
	18	3.9	3.2	4.6	3.5	5.3	3.7	5.6	3.8	5.8	3.8	6.2	3.8	6.6	3.6
	20	3.9	3.2	4.6	3.5	5.3	3.7	5.6	3.8	5.8	3.8	6.2	3.8	6.6	3.6
	21	3.9	3.2	4.6	3.5	5.3	3.7	5.6	3.8	5.8	3.8	6.2	3.8	6.6	3.6
	23	3.9	3.2	4.6	3.5	5.3	3.7	5.6	3.8	5.8	3.8	6.2	3.8	6.6	3.6
	25	3.9	3.2	4.6	3.5	5.3	3.7	5.6	3.8	5.8	3.8	6.2	3.8	6.6	3.6
	27	3.9	3.2	4.6	3.5	5.3	3.7	5.6	3.8	5.8	3.8	6.2	3.8	6.6	3.6
	29	3.9	3.2	4.6	3.5	5.3	3.7	5.6	3.8	5.8	3.8	6.2	3.8	6.6	3.6
	31	3.9	3.2	4.6	3.5	5.3	3.7	5.6	3.8	5.8	3.8	6.2	3.8	6.6	3.6
	33	3.9	3.2	4.6	3.5	5.3	3.7	5.6	3.8	5.8	3.8	6.2	3.8	6.6	3.6
	35	3.9	3.2	4.6	3.5	5.3	3.7	5.6	3.8	5.8	3.8	6.2	3.8	6.6	3.6
	37	3.9	3.2	4.6	3.5	5.3	3.7	5.6	3.8	5.8	3.8	6.1	3.7	6.5	3.5
	39	3.9	3.2	4.6	3.5	5.3	3.7	5.6	3.8	5.8	3.8	6.1	3.7	6.4	3.4
42	3.9	3.2	4.6	3.5	5.3	3.7	5.4	3.7	5.6	3.7	5.8	3.6	6.0	3.2	
44	3.9	3.2	4.6	3.5	5.0	3.6	5.3	3.6	5.4	3.6	5.5	3.5	5.6	3.0	
071	10	4.9	4.0	5.8	4.4	6.7	4.8	7.1	4.9	7.4	4.9	8.0	4.9	8.5	4.7
	12	4.9	4.0	5.8	4.4	6.7	4.8	7.1	4.9	7.4	4.9	7.9	4.8	8.5	4.7
	14	4.9	4.0	5.8	4.4	6.7	4.8	7.1	4.9	7.4	4.9	7.9	4.8	8.5	4.7
	16	4.9	4.0	5.8	4.4	6.7	4.8	7.1	4.9	7.4	4.9	7.9	4.8	8.4	4.6
	18	4.9	4.0	5.8	4.4	6.7	4.8	7.1	4.9	7.4	4.9	7.9	4.8	8.4	4.6
	20	4.9	4.0	5.8	4.4	6.7	4.8	7.1	4.9	7.4	4.9	7.9	4.8	8.4	4.6
	21	4.9	4.0	5.8	4.4	6.7	4.8	7.1	4.9	7.4	4.9	7.9	4.8	8.4	4.6
	23	4.9	4.0	5.8	4.4	6.7	4.8	7.1	4.9	7.4	4.9	7.9	4.8	8.4	4.6
	25	4.9	4.0	5.8	4.4	6.7	4.8	7.1	4.9	7.4	4.9	7.9	4.8	8.4	4.6
	27	4.9	4.0	5.8	4.4	6.7	4.8	7.1	4.9	7.4	4.9	7.9	4.8	8.4	4.6
	29	4.9	4.0	5.8	4.4	6.7	4.8	7.1	4.9	7.4	4.9	7.9	4.8	8.4	4.6
	31	4.9	4.0	5.8	4.4	6.7	4.8	7.1	4.9	7.4	4.9	7.9	4.8	8.4	4.6
	33	4.9	4.0	5.8	4.4	6.7	4.8	7.1	4.9	7.4	4.9	7.9	4.8	8.4	4.6
	35	4.9	4.0	5.8	4.4	6.7	4.8	7.1	4.9	7.4	4.9	7.9	4.8	8.4	4.6
	37	4.9	4.0	5.8	4.4	6.7	4.8	7.1	4.9	7.3	4.8	7.8	4.7	8.2	4.5
	39	4.9	4.0	5.8	4.4	6.7	4.8	7.1	4.9	7.3	4.8	7.7	4.6	8.1	4.4
42	4.9	4.0	5.8	4.4	6.7	4.8	6.9	4.8	7.0	4.6	7.3	4.4	7.6	4.2	
44	4.9	4.0	5.8	4.4	6.3	4.7	6.7	4.7	6.8	4.5	7.0	4.3	7.1	4.0	

Indoor units

2) Heating

TC : Total Capacity(kW)

Model	Outdoor temperature (°C)		Indoor temperature (°C, DB)									
			16.0		18.0		20.0		22.0		24.0	
			TC	kW	TC	kW	TC	kW	TC	kW	TC	kW
056	-20	-21	3.9		3.8		3.8		3.7		3.7	
	-17	-18	4.0		4.0		3.9		3.8		3.8	
	-15	-16	4.2		4.1		4.0		3.9		3.8	
	-12	-13	4.4		4.3		4.2		4.2		4.1	
	-10	-11	4.6		4.6		4.5		4.4		4.4	
	-7	-8	4.9		4.8		4.8		4.7		4.5	
	-5	-6	5.2		5.1		5.0		4.9		4.7	
	-3	-4	5.4		5.3		5.3		5.1		4.9	
	0	-1	5.7		5.6		5.5		5.3		5.0	
	3	2.2	5.9		5.9		5.8		5.6		5.3	
	5	4.1	6.2		6.1		6.0		5.7		5.3	
	7	6	6.5		6.4		6.3		5.8		5.3	
	9	7.9	6.7		6.5		6.3		5.8		5.3	
	11	9.8	6.9		6.6		6.3		5.8		5.3	
	13	12	7.1		6.7		6.3		5.8		5.3	
	15	14	7.3		6.8		6.3		5.8		5.3	
071	-20	-21	4.9		4.9		4.8		4.7		4.7	
	-17	-18	5.1		5.0		4.9		4.8		4.8	
	-15	-16	5.3		5.2		5.1		4.9		4.8	
	-12	-13	5.6		5.5		5.4		5.3		5.2	
	-10	-11	5.9		5.8		5.7		5.6		5.6	
	-7	-8	6.2		6.1		6.0		5.9		5.8	
	-5	-6	6.5		6.5		6.4		6.2		6.0	
	-3	-4	6.9		6.8		6.7		6.4		6.2	
	0	-1	7.2		7.1		7.0		6.7		6.4	
	3	2.2	7.6		7.5		7.3		7.1		6.8	
	5	4.1	7.9		7.8		7.7		7.2		6.8	
	7	6	8.2		8.1		8.0		7.4		6.8	
	9	7.9	8.5		8.2		8.0		7.4		6.8	
	11	9.8	8.7		8.4		8.0		7.4		6.8	
	13	12	9.0		8.5		8.0		7.4		6.8	
	15	14	9.2		8.6		8.0		7.4		6.8	

9 Ceiling

9-3. Dimensional drawing

Unit:mm

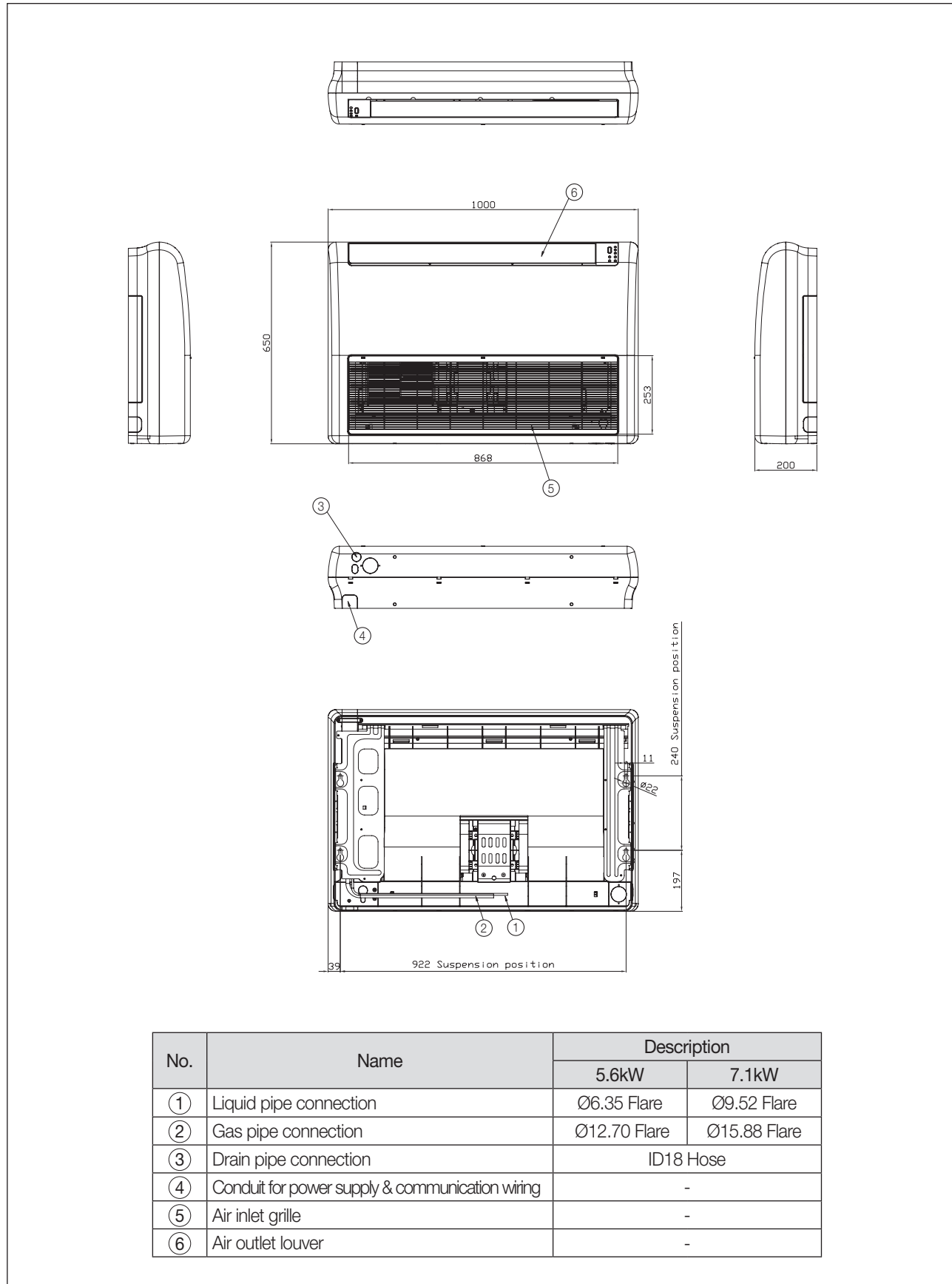

9-4. PCB connector lay-out

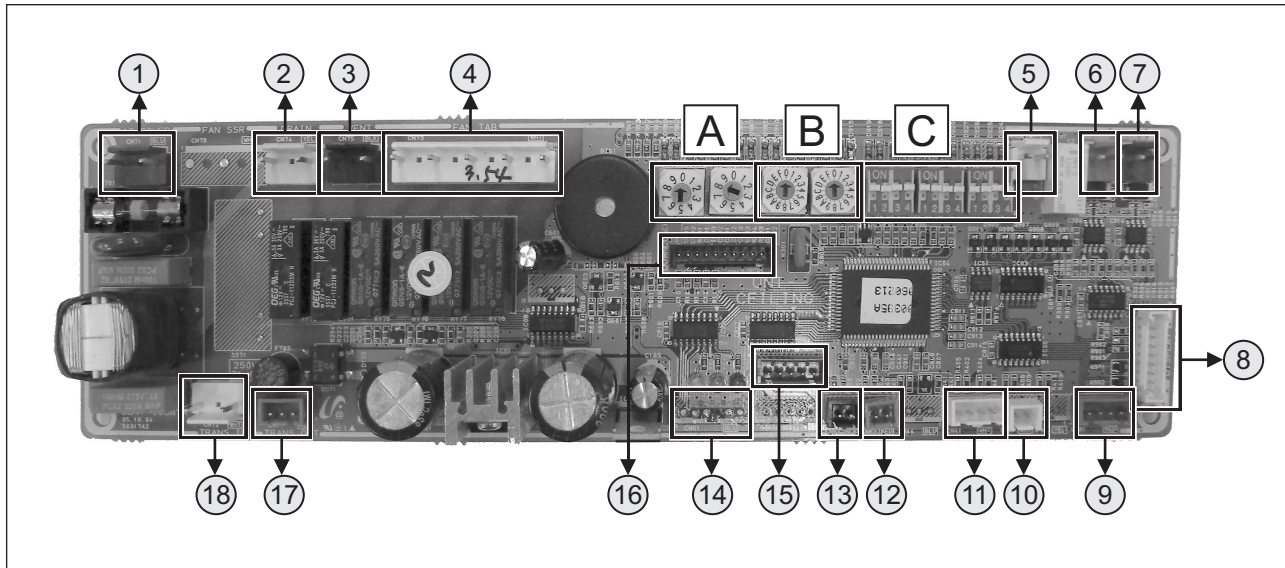

Indoor units

No.	CN #	COLOR	FUNCTION
①	CN71	Blue	AC 230V Input
②	CN74	Yellow	Drain Pump
③	CN75	Black	Ventilator
④	CN73	White	Fan Motor
⑤	CN32	White	DC12V for Wired Remote Controller
⑥	CN31	Red	Communication with Outdoor Units (COM1)
⑦	CN33	Blue	Communication with Wired Remote Controller (COM2)
⑧	CN91	White	Display
⑨	CN81	Red	Error Check, Indoor unit Operation
⑩	CN42	White	Eva-Out Sensor
⑪	CN41	White	Room Sensor, Eva-In Sensor
⑫	CN83	Red	External Contact Control
⑬	CN51	Black	Float Switch
⑭	CN61	Blue	Louver
⑮	CN62	Blue	EEV
⑯	CN10	Black	MICOM Download
⑰	CN11	Red	Trans-Out (AC 17V)
⑱	CN72	White	Trans-In (AC 230V)

No.	S/W	FUNCTION	
A	 SW01 SW02	Main Address Setting (00~63)	
		SW03	SW04
B	 SW03 SW04	Address of Interface Module Channel 0~2	Group Address (RMC) for Centralized Control 0~F

No.	S/W	FUNCTION	ON	OFF
C	K1	-	-	-
	K2	Centralized Controller	Not use	Use
	K3	RPM Up	Normal	Up
	K4	Optional Drain Pump	N/A	N/A
	K5	Heating Thermo-off	+2°C	+5°C
	K6	Filter Signal Display	1,000hrs	2,000hrs
	K7	Hot Water Coil	N/A	N/A
	K8	Electrical Heater	N/A	N/A
	K9	Min. EEV Step at Heating	Fixed 80 step	0 or 80 step
	K10	Priority of Indoor unit Display on Wired Remote Control	Slave (Default)	Master
	K11	External Contact Control	Not use	Use
	K12	-	-	-

9 Ceiling

9-5. Electrical wiring diagram

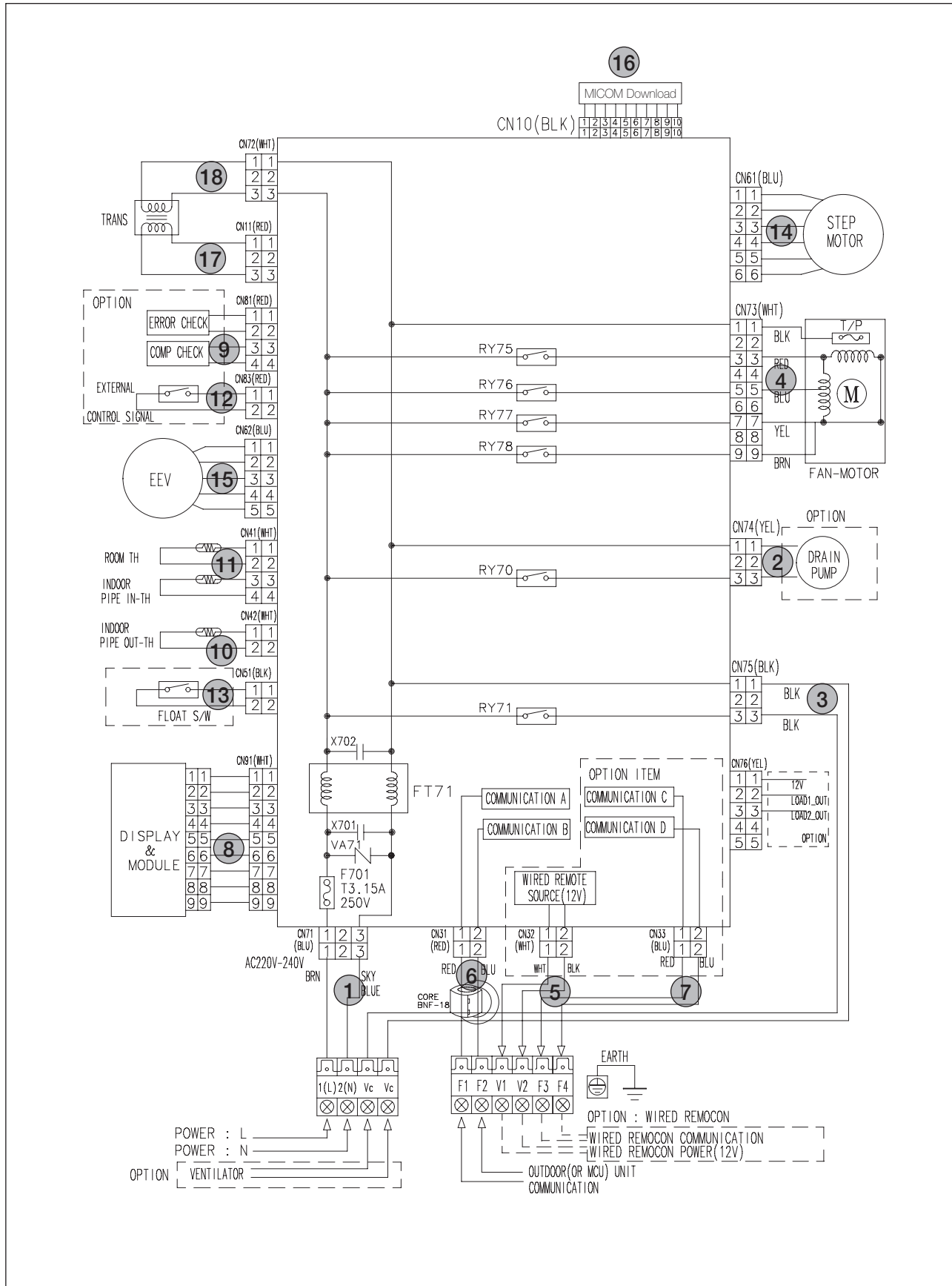

9-6. Sound pressure level

1) Operation sound level

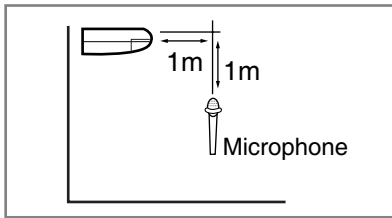

Unit : dB(A)

Model	High	Low
AVXTFH056E*	38	32
AVXTFH071E*	41	36

Note

- ◆ These operation values were obtained in a dead room. Sound pressure level will vary depending on a range of factors such as the construction of the particular room where the equipment is installed.
- ◆ Operation sound level may differ depending on operation and ambient conditions.

2) NC curves

(1) AVXTFH056E*

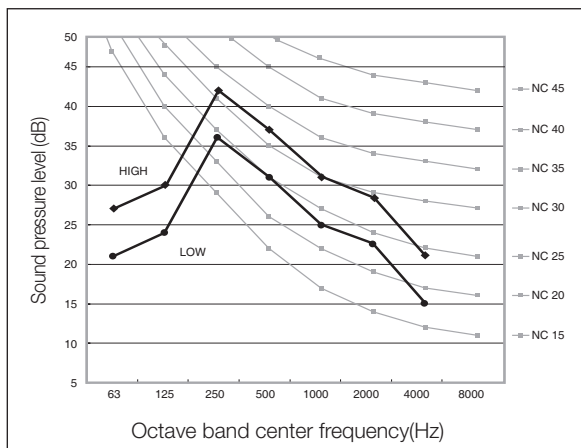

(2) AVXTFH071E*

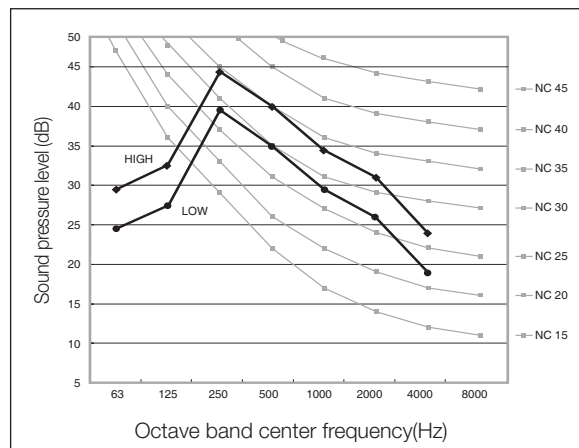

9-7. Temperature and air flow distribution

1) AVXTFH071E* (Floor installation)

(1) Cooling air velocity distribution

◆ Discharge angle : 36°

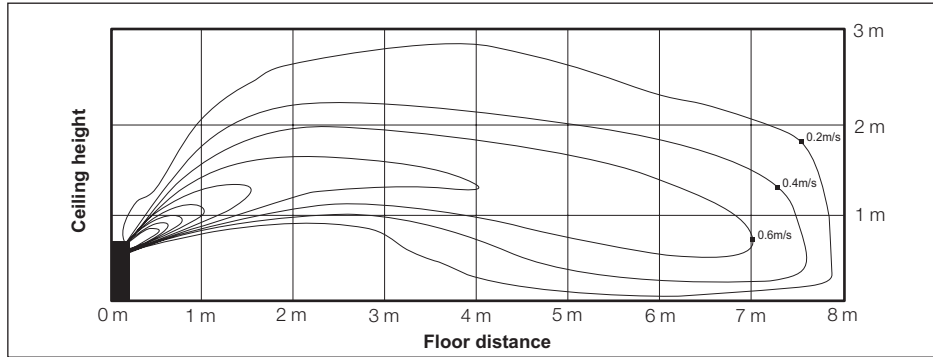

(2) Cooling temperature distribution

◆ Discharge angle : 36°

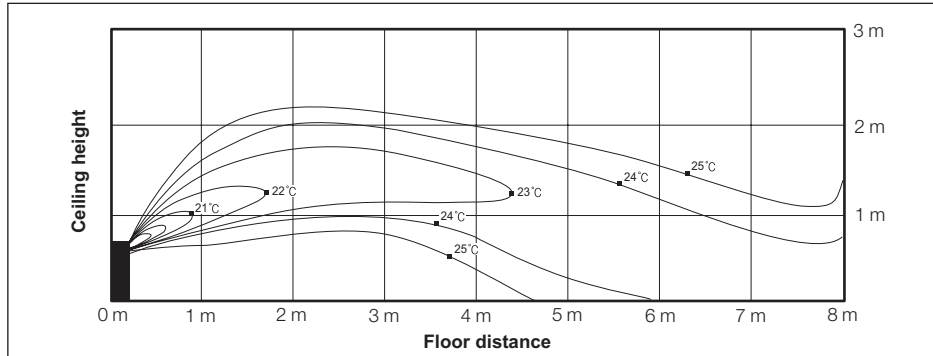

(3) Heating air velocity distribution

◆ Discharge angle : 54°

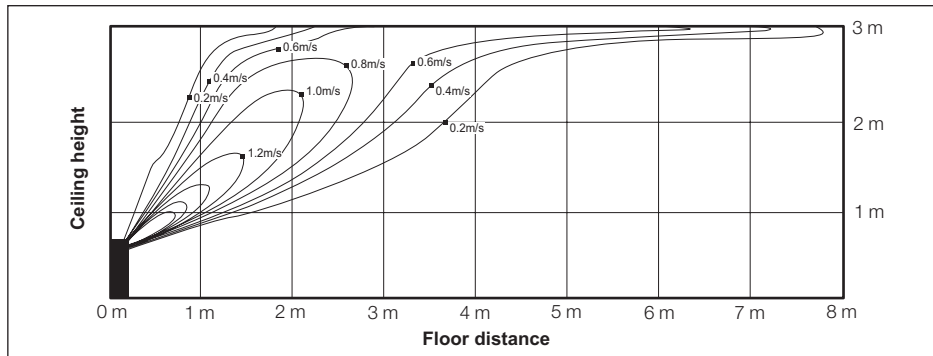

(4) Heating temperature distribution

◆ Discharge angle : 54°

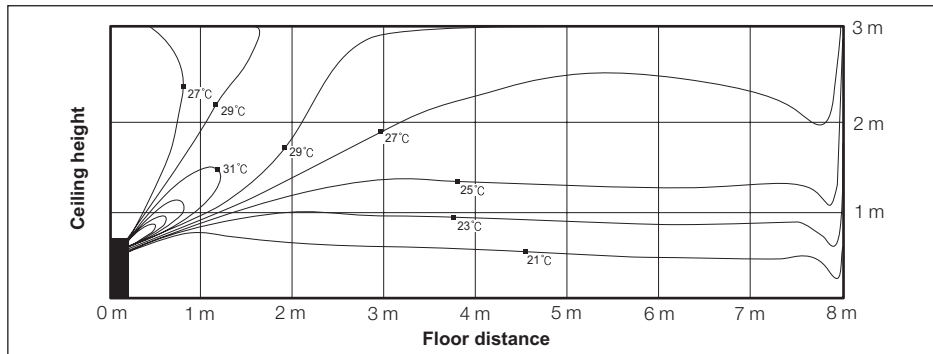

2) AVXTFH071E* (Ceiling installation)

(1) Cooling air velocity distribution

◆ Discharge angle : 36°

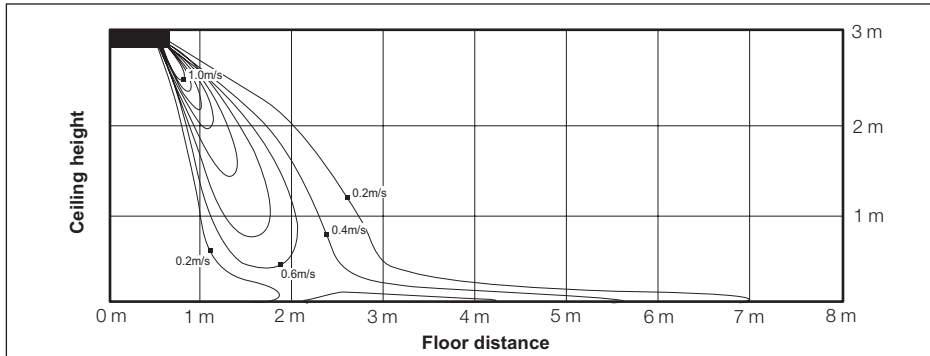

(2) Cooling temperature distribution

◆ Discharge angle : 36°

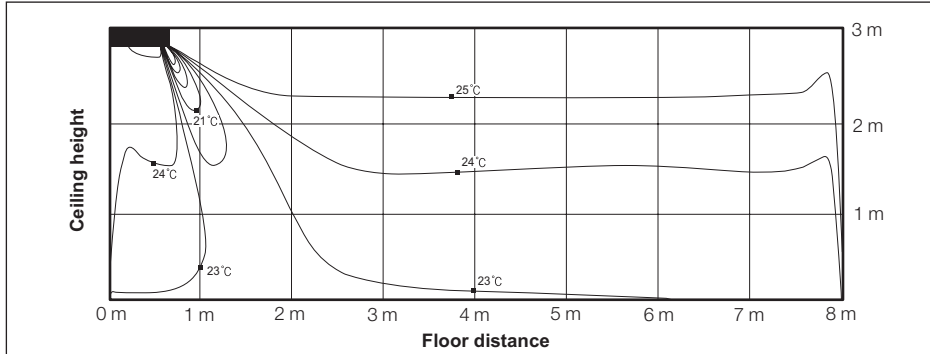

(3) Heating air velocity distribution

◆ Discharge angle : 54°

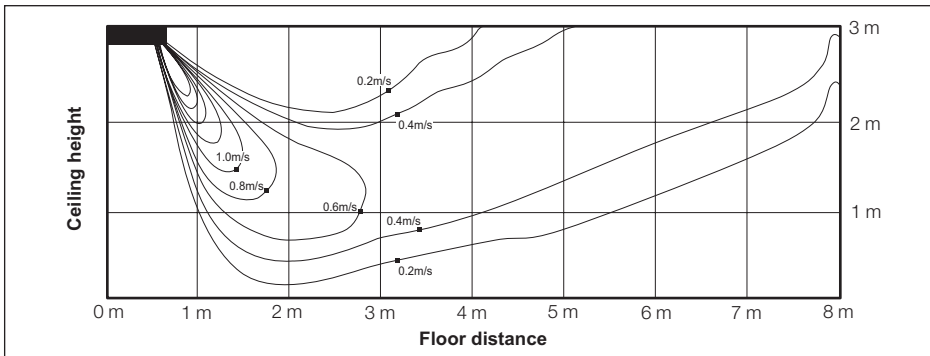

(4) Heating temperature distribution

◆ Discharge angle : 54°

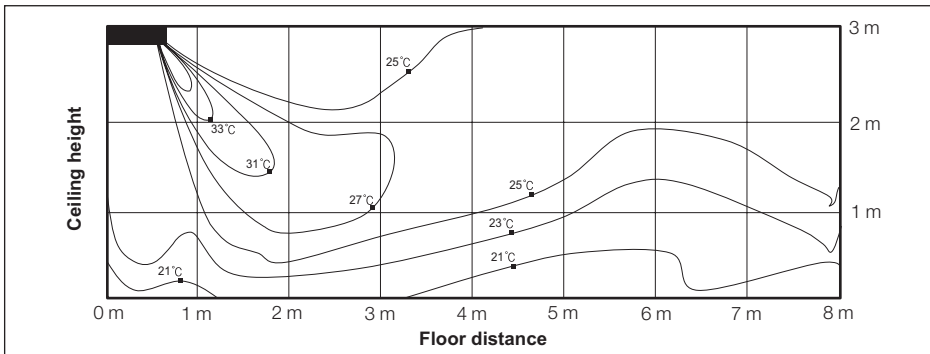



INDOOR UNIT



10 Neo Forte & Neo-Forte E (AVXWNH***E*/ND***QHXE*)

10-1. Features.....	128
10-2. Specifications	129
10-3. Capacity tables	130
10-4. Dimensional drawing.....	132
10-5. PCB connector lay-out.....	134
10-6. Electrical wiring diagram	136
10-7. Sound pressure level	138
10-8. Temperature and air flow distribution.....	140

Optional Accessories

Individual Controllers



MWR-WE10



MWR-WH00



MWR-SH00



MR-DH00

Standard Accessories

Wireless Remote Controller



10 Neo Forte & Neo-Forte E

10-1. Features



Multi Filter System

Multi Filter System is composed of Deodorizing filter to keep your air clean and fresh.

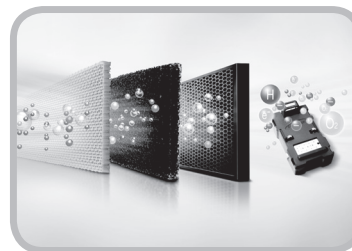

Internal EEV (Neo Forte-E)

EEV (Electronic Expansion Valve) equipped inside

- ▶ Easy installation and maintenance



Clean-Cut
Front Panel



Silver
Accent Line



Bottom
Opening
Front Panel

10-2. Specifications

1) Technical specifications

Model			AVXWNH022E*, ND022QHXE*	AVXWNH028E*, ND028QHXE*	AVXWNH036E*, ND036QHXE*	ND045QHXE*	AVXWNH056E*, ND056QHXE*	AVXWNH071E*, ND071QHXE*	
Power Supply			Ø, #, V, Hz	1, 2, 220~240, 50	1, 2, 220~240, 50	1, 2, 220~240, 50	1, 2, 220~240, 50	1, 2, 220~240, 50	
Mode ^{*1)}			-	HP / HR	HP / HR	HP / HR	HP / HR	HP / HR	
Capacity (Nominal)	Cooling ^{*2)}	kW	2.2	2.8	3.6	4.5	5.6	6.8	
		Btu/h	7,500	9,600	12,300	15,300	19,100	23,200	
	Heating ^{*3)}	kW	2.5	3.2	4.0	5.0	6.3	7.0	
		Btu/h	8,500	10,900	13,600	17,000	21,500	23,900	
Power	Power Input (Nominal)	Cooling ^{*2)}	W	25	25	30	40	45	50
		Heating ^{*3)}	W	25	25	30	40	45	50
	Current Input (Nominal)	Cooling ^{*2)}	A	0.16	0.16	0.18	0.18	0.27	0.30
		Heating ^{*3)}	A	0.16	0.16	0.18	0.18	0.27	0.30
Fan	Motor	Type	-	Crossflow Fan / SSR	Crossflow Fan / SSR	Crossflow Fan / SSR	Crossflow Fan / SSR	Crossflow Fan / SSR	
		Output	W	23	23	23	40	40	40
		Number of unit	EA	1	1	1	1	1	1
	Air Flow Rate	H/M/L (UL)	CMM	7.8 / 6.8 / 5.8	8.2 / 7.2 / 6.2	9.3 / 8.3 / 7.3	11.7 / 10.2 / 8.7	12 / 10.5 / 9	14 / 12.5 / 11
			CFM	280 / 240 / 200	290 / 250 / 220	330 / 290 / 260	410 / 360 / 310	420 / 370 / 320	490 / 440 / 390
	External Pressure	Min / Std / Max	mmAq	-	-	-	-	-	-
Pa			-	-	-	-	-	-	
Option Code			-	027602-1120FA- 200000-300000	027602-1320FA- 200000-300000	027602-15224d- 200000-300000	026602-18223F- 200000-300000	026602-1A226F- 200000-300000	026602-1C228F- 200000-300000
Piping Connections	Liquid Pipe	Ø, mm	6.35	6.35	6.35	6.35	6.35	9.52	
		Ø, inch	1/4	1/4	1/4	1/4	1/4	3/8	
	Gas Pipe	Ø, mm	12.7	12.7	12.7	12.7	12.7	15.88	
		Ø, inch	1/2	1/2	1/2	1/2	1/2	5/8	
Drain Pipe			Ø, mm	ID18 Hose (OD, ID)	ID18 Hose (OD, ID)	ID18 Hose (OD, ID)	ID18 Hose (OD, ID)	ID18 Hose (OD, ID)	
Field Wiring	Power Source Wire	Below 20m / over 20m	mm ²	1.5 / 2.5	1.5 / 2.5	1.5 / 2.5	1.5 / 2.5	1.5 / 2.5	
	Transmission Cable		mm ²	0.75 / 1.5	0.75 / 1.5	0.75 / 1.5	0.75 / 1.5	0.75 / 1.5	
Refrigerant	Type		-	R410A	R410A	R410A	R410A	R410A	
	Control Method		-	EEV (External) EEV (Internal)	EEV (External) EEV (Internal)	EEV (External) EEV (Internal)	EEV (Internal)	EEV (External) EEV (Internal)	EEV (External) EEV (Internal)
Sound	Sound Pressure	High / Low ^{*4)}	dBA	32 / 23, 35 / 26	32 / 23, 35 / 26	36 / 23, 39 / 26	39 / 33	40 / 30, 42 / 33	41 / 30, 44 / 33
			Net Weight	kg	8	8	8	13	13
Dimensions	Shipping Weight		kg	9	9	9	16	16	16
	Net Dimensions (W×H×D)		mm	825 x 285 x 189	825 x 285 x 189	825 x 285 x 189	1,065 x 298 x 218	1,065 x 298 x 218	1,065 x 298 x 218
	Shipping Dimensions (W×H×D)		mm	900 x 349 x 252	900 x 349 x 252	900 x 349 x 252	1,137 x 377 x 299	1,137 x 377 x 299	1,137 x 377 x 299
	Net Dimensions (W×H×D)		mm	-	-	-	-	-	-
Panel Size	Shipping Dimensions (W×H×D)		mm	-	-	-	-	-	-
	Panel model		-	-	-	-	-	-	-
	Panel Net Weight		kg	-	-	-	-	-	-
	Shipping Weight		kg	-	-	-	-	-	-
Additional Accessories	Drain pump	Drain pump	- / Model	-	-	-	-	-	
		Max. lifting Height / Displacement	mm/liter/h	-	-	-	-	-	
Air Filter			-	Full HD Filter	Full HD Filter	Full HD Filter	Full HD Filter	Full HD Filter	

* Neo-Forte E apply for new MCU kit (MCU-Y4NEE/MCU-Y6NEE)

* Specifications may be subject to change without prior notice for product improvement.

*1) Mode

- HP : Heat Pump, HR : Heat Recovery

*2) Nominal cooling capacities are based on;

- Indoor temperature : 27°C DB, 19°C WB

- Outdoor temperature : 35°C DB, 24°C WB, Equivalent refrigerant piping : 7.5m, Level differences : 0m

*3) Nominal heating capacities are based on;

- Indoor temperature : 20°C DB, 15°C WB

- Outdoor temperature : 7°C DB, 6°C WB, Equivalent refrigerant piping : 7.5m, Level differences : 0m

*4) Sound pressure was acquired in a dead room. Thus actual noise level may be different depending on the installation conditions.

10 Neo Forte & Neo-Forte E

10-3. Capacity tables

1) Cooling

TC : Total Capacity(kW), SHC : Sensible Heat Capacity(kW)

Model	Outdoor temperature (°C, DB)	Indoor temperature (°C, WB)													
		20 (°C, DB) 14 (°C, WB)		23 (°C, DB) 16 (°C, WB)		26 (°C, DB) 18 (°C, WB)		27 (°C, DB) 19 (°C, WB)		28 (°C, DB) 20 (°C, WB)		30 (°C, DB) 22 (°C, WB)		32 (°C, DB) 24 (°C, WB)	
		TC	SHC	TC	SHC	TC	SHC	TC	SHC	TC	SHC	TC	SHC	TC	SHC
022	10	1.5	1.3	1.8	1.5	2.1	1.5	2.2	1.5	2.3	1.5	2.5	1.6	2.6	1.4
	12	1.5	1.3	1.8	1.5	2.1	1.5	2.2	1.5	2.3	1.5	2.5	1.6	2.6	1.4
	14	1.5	1.3	1.8	1.5	2.1	1.5	2.2	1.5	2.3	1.5	2.5	1.6	2.6	1.4
	16	1.5	1.3	1.8	1.5	2.1	1.5	2.2	1.5	2.3	1.5	2.4	1.5	2.6	1.4
	18	1.5	1.3	1.8	1.5	2.1	1.5	2.2	1.5	2.3	1.5	2.4	1.5	2.6	1.4
	20	1.5	1.3	1.8	1.5	2.1	1.5	2.2	1.5	2.3	1.5	2.4	1.5	2.6	1.4
	21	1.5	1.3	1.8	1.5	2.1	1.5	2.2	1.5	2.3	1.5	2.4	1.5	2.6	1.4
	23	1.5	1.3	1.8	1.5	2.1	1.5	2.2	1.5	2.3	1.5	2.4	1.5	2.6	1.4
	25	1.5	1.3	1.8	1.5	2.1	1.5	2.2	1.5	2.3	1.5	2.4	1.5	2.6	1.4
	27	1.5	1.3	1.8	1.5	2.1	1.5	2.2	1.5	2.3	1.5	2.4	1.5	2.6	1.4
	29	1.5	1.3	1.8	1.5	2.1	1.5	2.2	1.5	2.3	1.5	2.4	1.5	2.6	1.4
	31	1.5	1.3	1.8	1.5	2.1	1.5	2.2	1.5	2.3	1.5	2.4	1.5	2.6	1.4
	33	1.5	1.3	1.8	1.5	2.1	1.5	2.2	1.5	2.3	1.5	2.4	1.5	2.6	1.4
	35	1.5	1.3	1.8	1.5	2.1	1.5	2.2	1.5	2.3	1.5	2.4	1.5	2.6	1.4
	37	1.5	1.3	1.8	1.5	2.1	1.5	2.2	1.5	2.3	1.5	2.4	1.5	2.6	1.4
39	1.5	1.3	1.8	1.5	2.1	1.5	2.2	1.5	2.3	1.5	2.4	1.5	2.5	1.3	
42	1.5	1.3	1.8	1.5	2.1	1.5	2.1	1.4	2.2	1.7	2.3	1.4	2.4	1.2	
44	1.5	1.3	1.8	1.5	2.0	1.4	2.1	1.4	2.1	1.6	2.2	1.3	2.2	1.1	
028	10	1.9	1.6	2.3	1.8	2.6	2.0	2.8	1.9	2.9	1.9	3.1	1.9	3.4	1.9
	12	1.9	1.6	2.3	1.8	2.6	2.0	2.8	1.9	2.9	1.9	3.1	1.9	3.3	1.8
	14	1.9	1.6	2.3	1.8	2.6	2.0	2.8	1.9	2.9	1.9	3.1	1.9	3.3	1.8
	16	1.9	1.6	2.3	1.8	2.6	2.0	2.8	1.9	2.9	1.9	3.1	1.9	3.3	1.8
	18	1.9	1.6	2.3	1.8	2.6	2.0	2.8	1.9	2.9	1.9	3.1	1.9	3.3	1.8
	20	1.9	1.6	2.3	1.8	2.6	2.0	2.8	1.9	2.9	1.9	3.1	1.9	3.3	1.8
	21	1.9	1.6	2.3	1.8	2.6	2.0	2.8	1.9	2.9	1.9	3.1	1.9	3.3	1.8
	23	1.9	1.6	2.3	1.8	2.6	2.0	2.8	1.9	2.9	1.9	3.1	1.9	3.3	1.8
	25	1.9	1.6	2.3	1.8	2.6	2.0	2.8	1.9	2.9	1.9	3.1	1.9	3.3	1.8
	27	1.9	1.6	2.3	1.8	2.6	2.0	2.8	1.9	2.9	1.9	3.1	1.9	3.3	1.8
	29	1.9	1.6	2.3	1.8	2.6	2.0	2.8	1.9	2.9	1.9	3.1	1.9	3.3	1.8
	31	1.9	1.6	2.3	1.8	2.6	2.0	2.8	1.9	2.9	1.9	3.1	1.9	3.3	1.8
	33	1.9	1.6	2.3	1.8	2.6	2.0	2.8	1.9	2.9	1.9	3.1	1.9	3.3	1.8
	35	1.9	1.6	2.3	1.8	2.6	2.0	2.8	1.9	2.9	1.9	3.1	1.9	3.3	1.8
	37	1.9	1.6	2.3	1.8	2.6	2.0	2.8	1.9	2.9	1.9	3.1	1.9	3.3	1.8
39	1.9	1.6	2.3	1.8	2.6	2.0	2.8	1.9	2.9	1.9	3.0	1.8	3.2	1.7	
42	1.9	1.6	2.3	1.8	2.6	2.0	2.7	1.8	2.8	1.8	2.9	1.7	3.0	1.6	
44	1.9	1.6	2.3	1.8	2.5	1.9	2.7	1.8	2.7	1.7	2.7	1.6	2.8	1.5	
036	10	2.5	2.1	2.9	2.2	3.4	2.3	3.6	2.4	3.7	2.4	4.0	2.4	4.3	2.3
	12	2.5	2.1	2.9	2.2	3.4	2.3	3.6	2.4	3.7	2.4	4.0	2.4	4.3	2.3
	14	2.5	2.1	2.9	2.2	3.4	2.3	3.6	2.4	3.7	2.4	4.0	2.4	4.3	2.3
	16	2.5	2.1	2.9	2.2	3.4	2.3	3.6	2.4	3.7	2.4	4.0	2.4	4.3	2.3
	18	2.5	2.1	2.9	2.2	3.4	2.3	3.6	2.4	3.7	2.4	4.0	2.4	4.3	2.3
	20	2.5	2.1	2.9	2.2	3.4	2.3	3.6	2.4	3.7	2.4	4.0	2.4	4.2	2.3
	21	2.5	2.1	2.9	2.2	3.4	2.3	3.6	2.4	3.7	2.4	4.0	2.4	4.2	2.3
	23	2.5	2.1	2.9	2.2	3.4	2.3	3.6	2.4	3.7	2.4	4.0	2.4	4.2	2.3
	25	2.5	2.1	2.9	2.2	3.4	2.3	3.6	2.4	3.7	2.4	4.0	2.4	4.2	2.3
	27	2.5	2.1	2.9	2.2	3.4	2.3	3.6	2.4	3.7	2.4	4.0	2.4	4.2	2.3
	29	2.5	2.1	2.9	2.2	3.4	2.3	3.6	2.4	3.7	2.4	4.0	2.4	4.2	2.3
	31	2.5	2.1	2.9	2.2	3.4	2.3	3.6	2.4	3.7	2.4	4.0	2.4	4.2	2.3
	33	2.5	2.1	2.9	2.2	3.4	2.3	3.6	2.4	3.7	2.4	4.0	2.4	4.2	2.3
	35	2.5	2.1	2.9	2.2	3.4	2.3	3.6	2.4	3.7	2.4	4.0	2.4	4.2	2.3
	37	2.5	2.1	2.9	2.2	3.4	2.3	3.6	2.4	3.7	2.4	3.9	2.3	4.2	2.3
39	2.5	2.1	2.9	2.2	3.4	2.3	3.6	2.4	3.7	2.4	3.9	2.3	4.1	2.2	
42	2.5	2.1	2.9	2.2	3.4	2.3	3.5	2.3	3.6	2.3	3.7	2.2	3.9	2.1	
44	2.5	2.1	2.9	2.2	3.2	2.2	3.4	2.2	3.5	2.2	3.5	2.1	3.6	1.9	
056	10	3.9	3.0	4.6	3.4	5.3	3.7	5.6	3.8	5.8	3.8	6.3	3.9	6.7	3.6
	12	3.9	3.0	4.6	3.4	5.3	3.7	5.6	3.8	5.8	3.8	6.3	3.9	6.7	3.6
	14	3.9	3.0	4.6	3.4	5.3	3.7	5.6	3.8	5.8	3.8	6.2	3.8	6.7	3.6
	16	3.9	3.0	4.6	3.4	5.3	3.7	5.6	3.8	5.8	3.8	6.2	3.8	6.6	3.5
	18	3.9	3.0	4.6	3.4	5.3	3.7	5.6	3.8	5.8	3.8	6.2	3.8	6.6	3.5
	20	3.9	3.0	4.6	3.4	5.3	3.7	5.6	3.8	5.8	3.8	6.2	3.8	6.6	3.5
	21	3.9	3.0	4.6	3.4	5.3	3.7	5.6	3.8	5.8	3.8	6.2	3.8	6.6	3.5
	23	3.9	3.0	4.6	3.4	5.3	3.7	5.6	3.8	5.8	3.8	6.2	3.8	6.6	3.5
	25	3.9	3.0	4.6	3.4	5.3	3.7	5.6	3.8	5.8	3.8	6.2	3.8	6.6	3.5
	27	3.9	3.0	4.6	3.4	5.3	3.7	5.6	3.8	5.8	3.8	6.2	3.8	6.6	3.5
	29	3.9	3.0	4.6	3.4	5.3	3.7	5.6	3.8	5.8	3.8	6.2	3.8	6.6	3.5
	31	3.9	3.0	4.6	3.4	5.3	3.7	5.6	3.8	5.8	3.8	6.2	3.8	6.6	3.5
	33	3.9	3.0	4.6	3.4	5.3	3.7	5.6	3.8	5.8	3.8	6.2	3.8	6.6	3.5
	35	3.9	3.0	4.6	3.4	5.3	3.7	5.6	3.8	5.8	3.8	6.2	3.8	6.6	3.5
	37	3.9	3.0	4.6	3.4	5.3	3.7	5.6	3.8	5.8	3.8	6.1	3.7	6.5	3.4
39	3.9	3.0	4.6	3.4	5.3	3.7	5.6	3.8	5.8	3.8	6.1	3.7	6.4	3.3	
42	3.9	3.0	4.6	3.4	5.3	3.7	5.4	3.7	5.6	3.7	5.8	3.6	6.0	3.2	
44	3.9	3.0	4.6	3.4	5.0	3.6	5.3	3.6	5.4	3.6	5.5	3.5	5.6	3.0	
071	10	4.7	3.7	5.5	4.1	6.4	4.5	6.8	4.6	7.1	4.6	7.6	4.6	8.2	4.4
	12	4.7	3.7	5.5	4.1	6.4	4.5	6.8	4.6	7.1	4.6	7.6	4.6	8.1	4.3
	14	4.7	3.7	5.5	4.1	6.4	4.5	6.8	4.6	7.1	4.6	7.6	4.6	8.1	4.3
	16	4.7	3.7	5.5	4.1	6.4	4.5	6.8	4.6	7.1	4.6	7.6	4.6	8.1	4.3
	18	4.7	3.7	5.5	4.1	6.4	4.5	6.8	4.6	7.0	4.6	7.5	4.5	8.0	4.2
	20	4.7	3.7	5.5	4.1	6.4	4.5	6.8	4.6	7.0	4.6	7.5	4.5	8.0	4.2
	21	4.7	3.7	5.5	4.1	6.4	4.5	6.8	4.6	7.0	4.6	7.5	4.5	8.0	4.2
	23	4.7	3.7	5.5	4.1	6.4	4.5	6.8	4.6	7.0	4.6	7.5	4.5	8.0	4.2
	25	4.7	3.7	5.5	4.1	6.4	4.5	6.8	4.6	7.0	4.6	7.5	4.5	8.0	4.2
	27	4.7	3.7	5.5	4.1	6.4	4.5	6.8	4.6	7.0	4.6	7.5	4.5	8.0	4.2
	29	4.7	3.7	5.5	4.1	6.4	4.5	6.8	4.6	7.0	4.6	7.5	4.5	8.0	4.2
	31	4.7	3.7	5.5	4.1	6.4	4.5	6.8	4.6	7.0	4.6	7.5	4.5	8.0	4.2
	33	4.7	3.7	5.5	4.1	6.4	4.5	6.8	4.6	7.0	4.6	7.5	4.5	8.0	4.2
	35	4.7	3.7	5.5	4.1	6.4	4.5	6.8	4.6	7.0	4.6	7.5	4.5	8.0	4.2
	37	4.7	3.7	5.5	4.1	6.4	4.5	6.8	4.6	7.0	4.6	7.5	4.5	7.9	4.1
39	4.7	3.7	5.5	4.1	6.4	4.5	6.8	4.6	7.0	4.6	7.4	4.4	7.7	4.0	
42	4.7	3.7	5.5	4.1	6.4	4.5	6.6	4.5	6.7	4.4	7.0	4.2	7.3	3.8	
44	4.7	3.7	5.5	4.1	6.1	4.4	6.5	4.4	6.5	4.3	6.7	4.1	6.8	3.6	

2) Heating

TC : Total Capacity(kW)

Model	Outdoor temperature (°C)		Indoor temperature (°C, DB)				
			16.0	18.0	20.0	22.0	24.0
	DB	WB	TC	TC	TC	TC	TC
022	-20	-21	1.5	1.5	1.5	1.5	1.5
	-17	-18	1.6	1.6	1.6	1.6	1.6
	-15	-16	1.7	1.6	1.6	1.6	1.6
	-12	-13	1.8	1.8	1.8	1.8	1.7
	-10	-11	2.0	2.0	1.9	1.9	1.9
	-7	-8	2.3	2.2	2.2	2.0	2.0
	-5	-6	2.4	2.3	2.3	2.2	2.2
	-3	-4	2.5	2.5	2.4	2.3	2.2
	0	-1	2.6	2.5	2.5	2.3	2.2
	3	2.2	2.7	2.6	2.5	2.3	2.2
	5	4.1	2.8	2.7	2.5	2.3	2.2
	7	6	2.8	2.7	2.5	2.3	2.2
	9	7.9	3.0	2.7	2.5	2.3	2.2
	11	9.8	3.0	2.7	2.5	2.3	2.2
	13	12	3.0	2.7	2.5	2.3	2.2
15	14	3.0	2.7	2.5	2.3	2.2	
028	-20	-21	1.9	1.9	1.9	1.9	1.9
	-17	-18	2.0	2.0	2.0	2.0	1.9
	-15	-16	2.1	2.1	2.0	2.0	1.9
	-12	-13	2.2	2.2	2.2	2.1	2.1
	-10	-11	2.3	2.3	2.3	2.3	2.2
	-7	-8	2.5	2.4	2.4	2.4	2.3
	-5	-6	2.6	2.6	2.5	2.5	2.4
	-3	-4	2.8	2.7	2.7	2.6	2.5
	0	-1	2.9	2.8	2.8	2.7	2.6
	3	2.2	3.0	3.0	2.9	2.8	2.7
	5	4.1	3.2	3.1	3.1	2.9	2.7
	7	6	3.3	3.2	3.2	3.0	2.7
	9	7.9	3.4	3.3	3.2	3.0	2.7
	11	9.8	3.5	3.3	3.2	3.0	2.7
	13	12	3.6	3.4	3.2	3.0	2.7
15	14	3.7	3.4	3.2	3.0	2.7	
036	-20	-21	2.4	2.4	2.3	2.3	2.3
	-17	-18	2.6	2.5	2.4	2.4	2.3
	-15	-16	2.7	2.6	2.5	2.5	2.4
	-12	-13	2.8	2.7	2.7	2.6	2.6
	-10	-11	2.9	2.9	2.9	2.8	2.8
	-7	-8	3.1	3.1	3.0	3.0	2.9
	-5	-6	3.3	3.2	3.2	3.1	3.0
	-3	-4	3.4	3.4	3.3	3.2	3.1
	0	-1	3.6	3.6	3.5	3.4	3.2
	3	2.2	3.8	3.7	3.7	3.5	3.4
	5	4.1	3.9	3.9	3.8	3.6	3.4
	7	6	4.1	4.1	4.0	3.7	3.4
	9	7.9	4.2	4.1	4.0	3.7	3.4
	11	9.8	4.4	4.2	4.0	3.7	3.4
	13	12	4.5	4.2	4.0	3.7	3.4
15	14	4.6	4.3	4.0	3.7	3.4	
056	-20	-21	3.9	3.8	3.8	3.7	3.7
	-17	-18	4.0	4.0	3.9	3.8	3.8
	-15	-16	4.2	4.1	4.0	3.9	3.8
	-12	-13	4.4	4.3	4.2	4.2	4.1
	-10	-11	4.6	4.6	4.5	4.4	4.4
	-7	-8	4.9	4.8	4.8	4.7	4.5
	-5	-6	5.2	5.1	5.0	4.9	4.7
	-3	-4	5.4	5.3	5.3	5.1	4.9
	0	-1	5.7	5.6	5.5	5.3	5.0
	3	2.2	5.9	5.9	5.8	5.6	5.3
	5	4.1	6.2	6.1	6.0	5.7	5.3
	7	6	6.5	6.4	6.3	5.8	5.3
	9	7.9	6.7	6.5	6.3	5.8	5.3
	11	9.8	6.9	6.6	6.3	5.8	5.3
	13	12	7.1	6.7	6.3	5.8	5.3
15	14	7.3	6.8	6.3	5.8	5.3	
071	-20	-21	4.4	4.3	4.2	4.2	4.2
	-17	-18	4.5	4.4	4.3	4.3	4.2
	-15	-16	4.7	4.6	4.4	4.3	4.2
	-12	-13	4.9	4.8	4.7	4.6	4.5
	-10	-11	5.1	5.1	5.0	4.9	4.9
	-7	-8	5.4	5.4	5.3	5.2	5.1
	-5	-6	5.7	5.6	5.6	5.4	5.2
	-3	-4	6.0	5.9	5.9	5.6	5.4
	0	-1	6.3	6.2	6.1	5.9	5.6
	3	2.2	6.6	6.5	6.4	6.2	5.9
	5	4.1	6.9	6.8	6.7	6.3	5.9
	7	6	7.2	7.1	7.0	6.5	5.9
	9	7.9	7.4	7.2	7.0	6.5	5.9
	11	9.8	7.6	7.3	7.0	6.5	5.9
	13	12	7.9	7.4	7.0	6.5	5.9
15	14	8.1	7.5	7.0	6.5	5.9	

Indoor units

10 Neo Forte & Neo-Forte E

10-4. Dimensional drawing

1) AVXWNH022/028/036E*, ND022/028/036QHxE*

Unit:mm

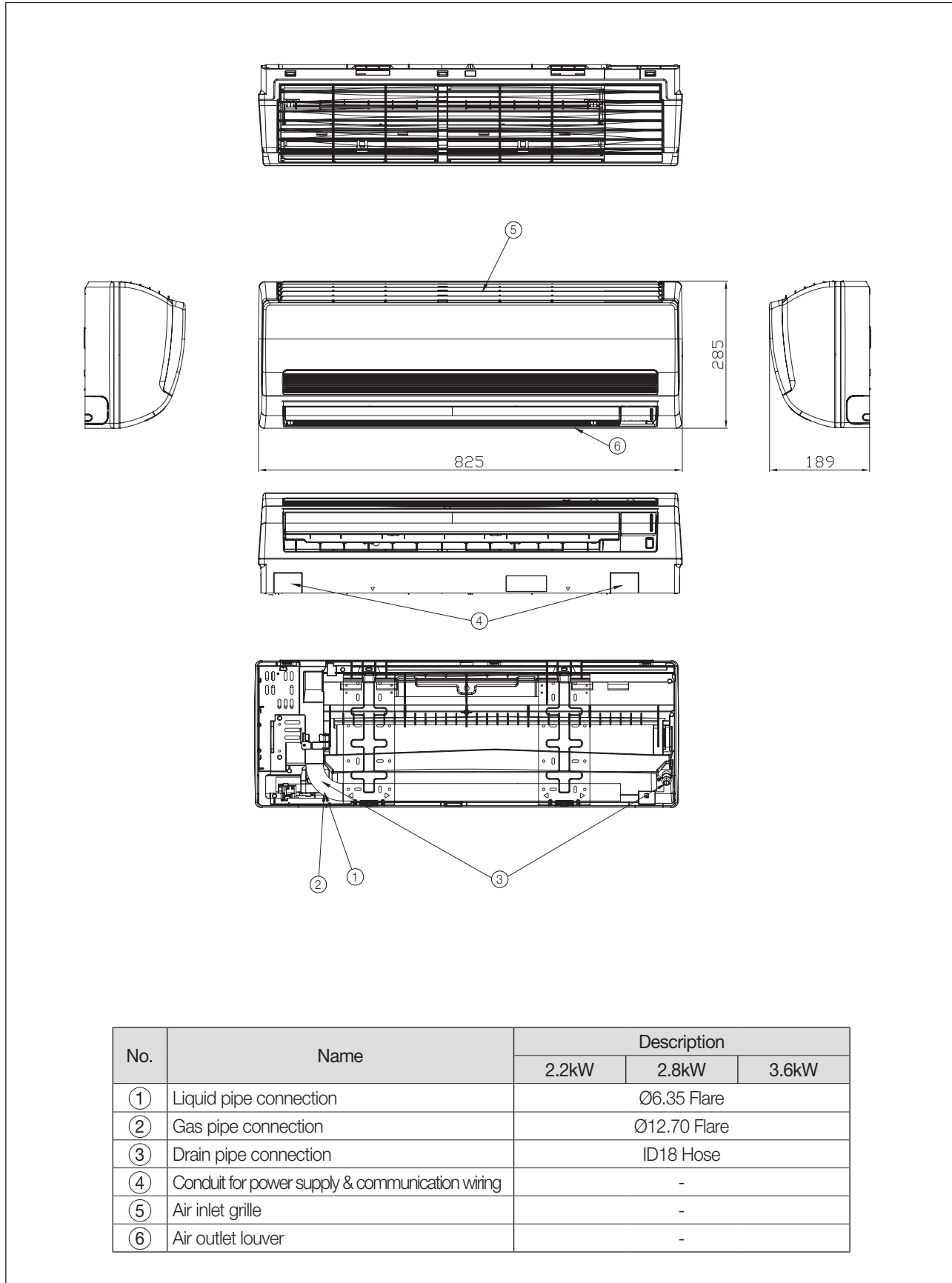

2) AVXWNH056/071E*, ND045/056/071QHxE*

Unit:mm

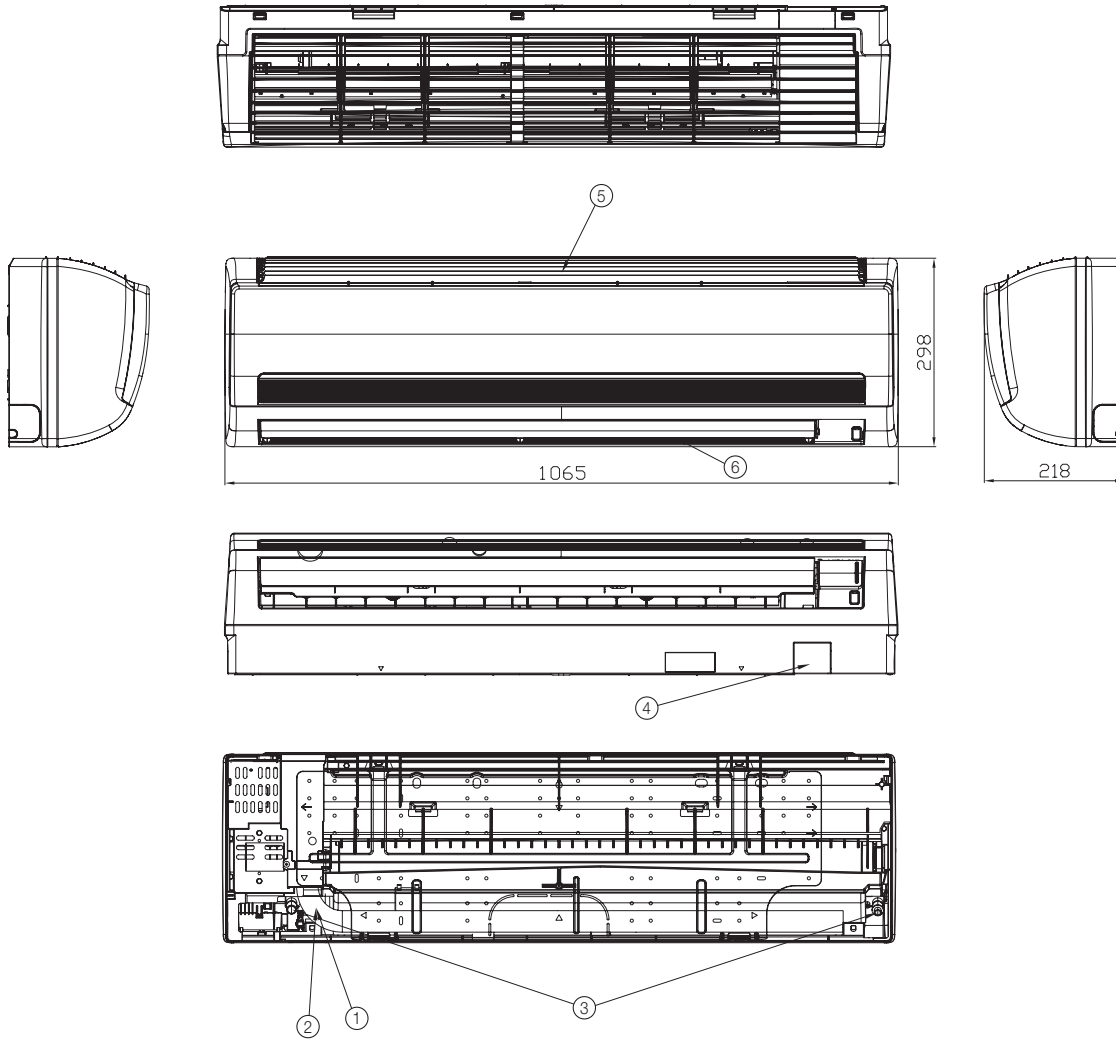

Indoor units

No.	Name	Description	
		4.5/5.6 kW	7.1kW
①	Liquid pipe connection	Ø6.35 Flare	Ø9.52 Flare
②	Gas pipe connection	Ø12.70 Flare	Ø15.88 Flare
③	Drain pipe connection	ID18 Hose	
④	Conduit for power supply & communication wiring	-	
⑤	Air inlet grille	-	
⑥	Air outlet louver	-	

10 Neo Forte & Neo-Forte E

10-5. PCB connector lay-out

1) Neo Forte (Non EEV)

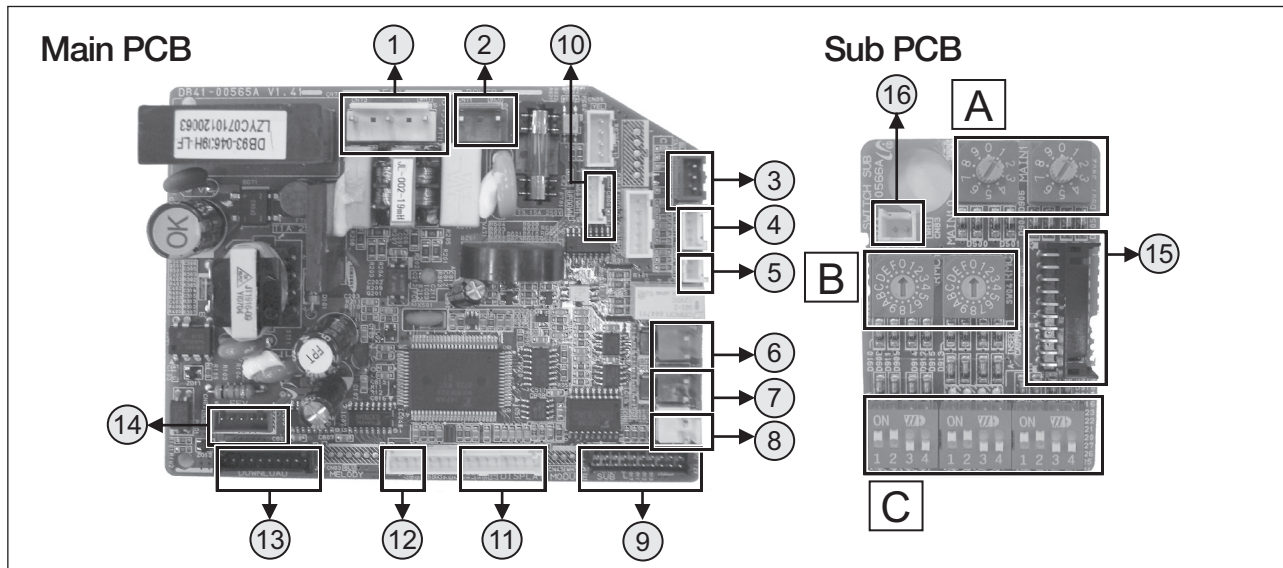

Main PCB

No.	CN #	COLOR	FUNCTION
①	CN73	White	Fan Motor
②	CN71	Blue	AC 230V Input
③	CN44	Blue	Hall IC
④	CN41	White	Eva-Out Sensor
⑤	CN42	White	Communication with Outdoor Units (COM1)
⑥	CN31	Red	Communication with Wired Remote Controller (COM2)
⑦	CN33	Blue	DC12V for Wired remote controller
⑧	CN32	White	Main-Sub PCB connector
⑨	CN61	Black	Main-Sub PCB connector
⑩	CN60	White	Up&Down Stepping Motor
⑪	CN92	White	Display
⑫	CN93	White	Display
⑬	CN10	Black	MICOM Download
⑭	CN62	Blue	EEV

Sub PCB

No.	CN #	COLOR	FUNCTION
⑮	CN61	Black	Main-Sub PCB Connector
⑯	CN83	White	External Contact Control

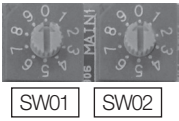
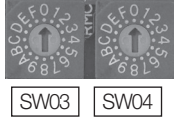
No.	S/W	FUNCTION	
A		Main Address Setting (00~63)	
B		SW03	SW04
		Address of Interface Module Channel 0~2	Group Address (RMC) for Centralized Control 0~F

No.	S/W	FUNCTION	ON	OFF
C	K1	-	-	-
	K2	Centralized Controller	Not use	Use
	K3	RPM Up	N/A	N/A
	K4	Optional Drain Pump	N/A	N/A
	K5	Heating Thermo-off	+2°C	+5°C
	K6	Filter Signal Display	1,000hrs	2,000hrs
	K7	Hot Water Coil	N/A	N/A
	K8	Electrical Heater	N/A	N/A
	K9	Min. EEV Step at Heating	Fixed 80 step	0 or 80 step
	K10	Priority of Indoor unit Display on Wired Remote Controlle	Slave (Default)	Master
	K11	External Contact Control	Not use	Use
	K12	-	-	-

2) Neo Forte E (EEV Internal)

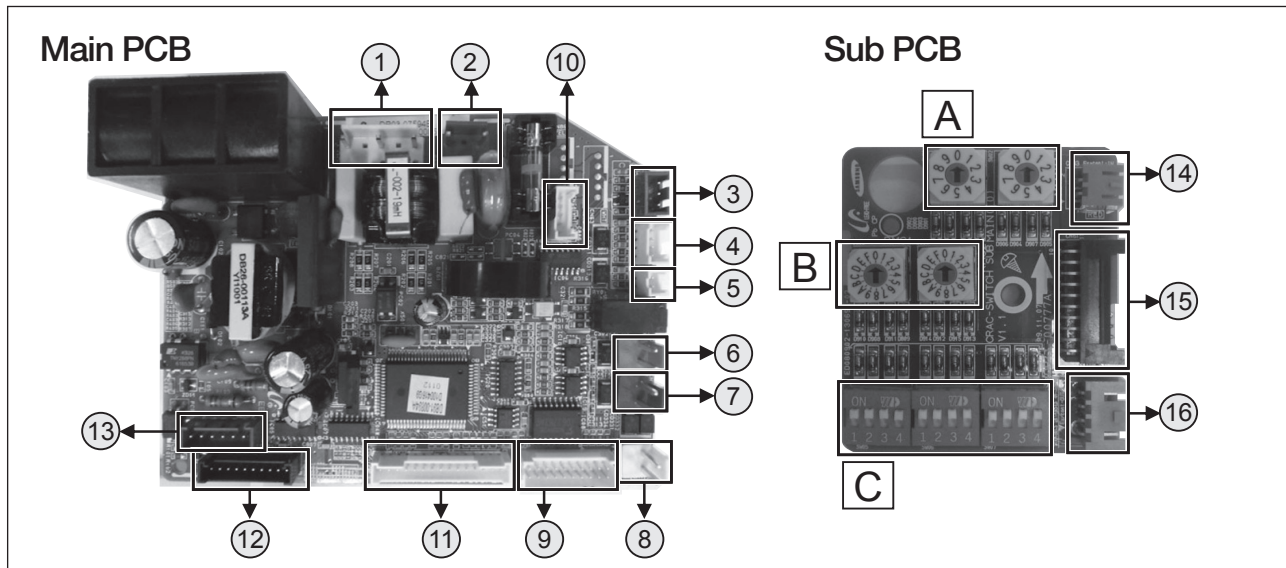

Indoor units

Main PCB

No.	CN #	COLOR	FUNCTION
①	CN73	White	Fan Motor
②	CN71	Blue	AC 230V Input
③	CN44	Blue	Hall IC
④	CN41	White	Room Sensor, Eva-In Sensor
⑤	CN42	White	Eva-Out Sensor
⑥	CN31	Red	Communication with Outdoor Units (COM1)
⑦	CN33	Blue	Communication with Wired Remote Controller (COM2)
⑧	CN32	White	DC12V for Wired remote controller
⑨	CN61	Black	Main-Sub PCB connector
⑩	CN60	White	Up&Down Stepping Motor
⑪	CN92	White	Display
⑫	CN10	Black	MICOM Download
⑬	CN62	Blue	EEV

Sub PCB

No.	CN #	COLOR	FUNCTION
⑭	CN83	Red	External Contact Control
⑮	CN61	Black	Main-Sub PCB Connector
⑯	CN42	Red	DC12V External Control

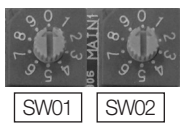
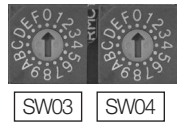
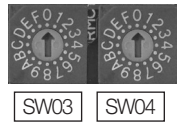
No.	S/W	FUNCTION	
A		Main Address Setting (00~63)	
B		SW03	SW04
		Address of Interface Module Channel 0~2	
C		Group Address (RMC) for Centralized Control 0~F	

No.	S/W	FUNCTION	ON	OFF
C	K1	-	-	-
	K2	Centralized Controller	Not use	Use
	K3	RPM Up	N/A	N/A
	K4	Optional Drain Pump	N/A	N/A
	K5	Heating Thermo-off	+2°C	+5°C
	K6	Filter Signal Display	1,000hrs	2,000hrs
	K7	Hot Water Coil	N/A	N/A
	K8	Electrical Heater	N/A	N/A
	K9	Min. EEV Step at Heating	Fixed 80 step	0 or 80 step
	K10	Priority of Indoor unit Display on Wired Remote Control	Slave (Default)	Master
	K11	External Contact Control	Not use	Use
	K12	-	-	-

10 Neo Forte & Neo-Forte E

10-6. Electrical wiring diagram

1) Neo Forte (Non EEV)

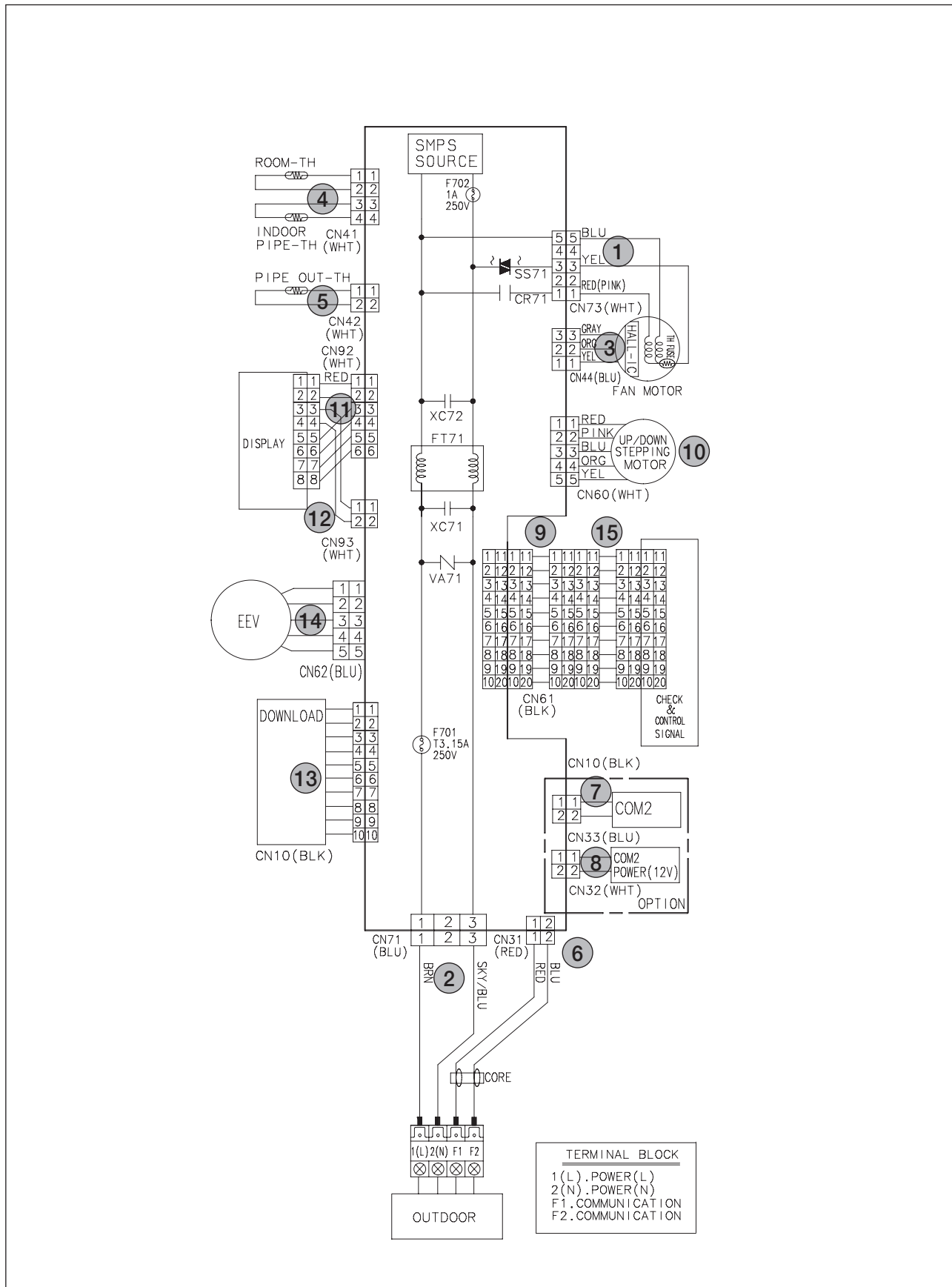

2) Neo Forte E (EEV Internal)

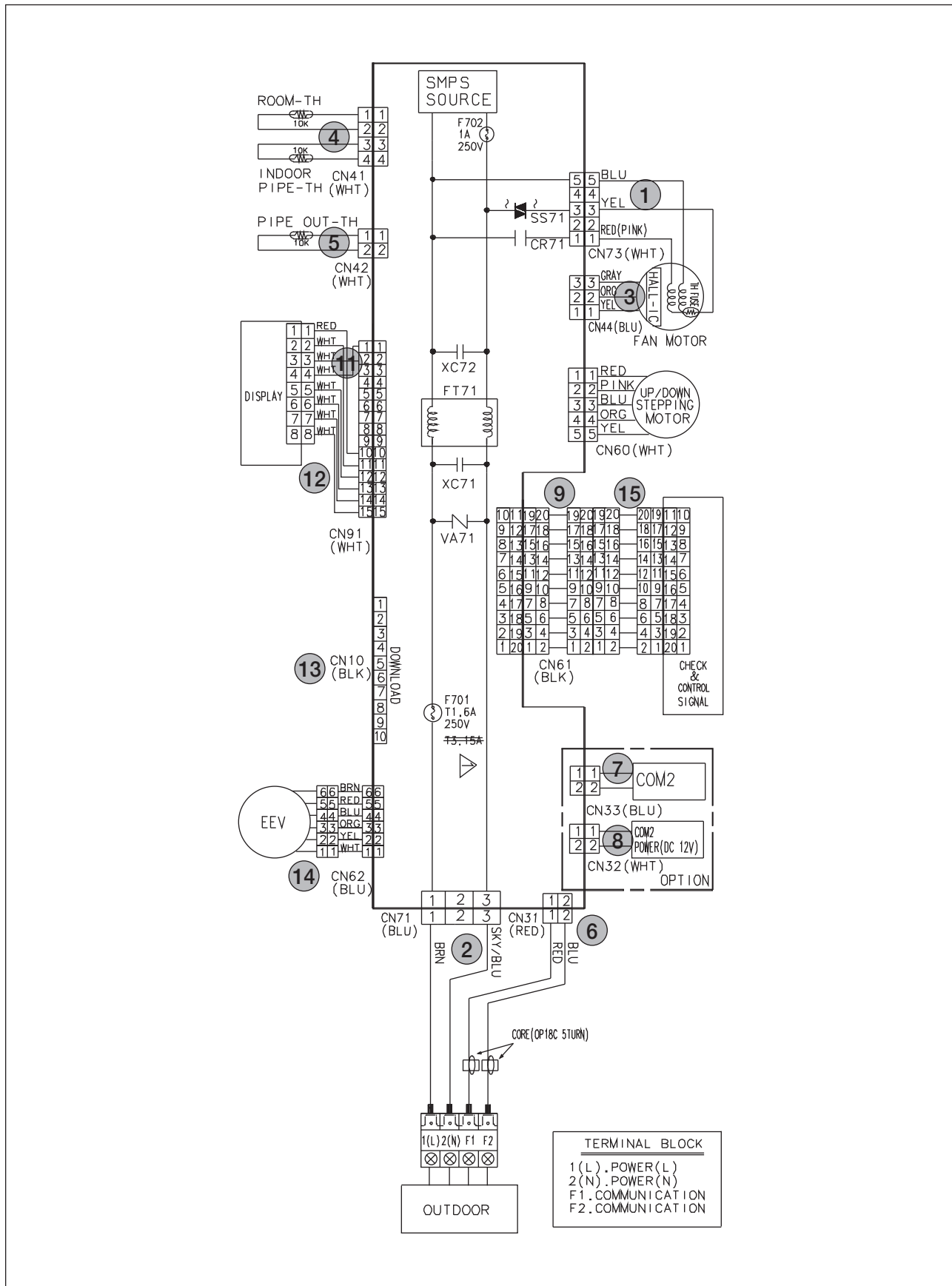

Indoor units

10 Neo Forte & Neo-Forte E

10-7. Sound pressure level

1) Operation sound level

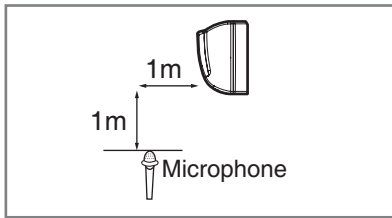

Model	High	Low
AVXWNH022E*	32	23
AVXWNH028E*	32	23
AVXWNH036E*	36	23
AVXWNH056E*	40	30
AVXWNH071E*	41	30

Unit : dB(A)

Model	High	Low
ND022QHXE*	35	26
ND028QHXE*	35	26
ND036QHXE*	39	26
ND045QHXE*	39	33
ND056QHXE*	42	33
ND071QHXE*	44	33

Note

- ◆ These operation values were obtained in a dead room. Sound pressure level will vary depending on a range of factors such as the construction of the particular room where the equipment is installed.
- ◆ Operation sound level may differ depending on operation and ambient conditions.

2) NC curves

(1) AVXWNH022E*

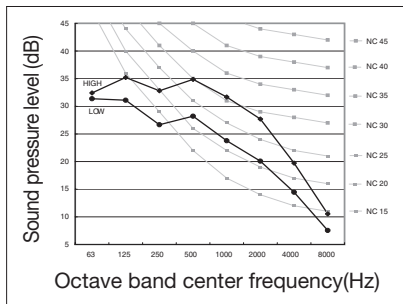

(2) AVXWNH028E*

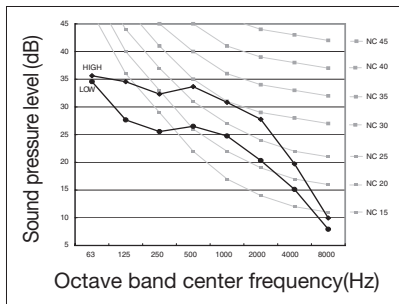

(3) AVXWNH036E*

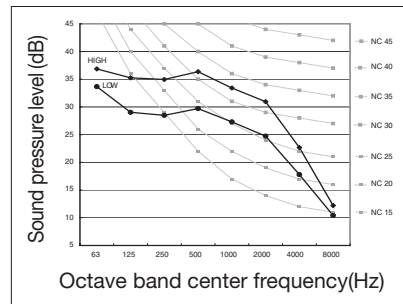

(4) AVXWNH056E*

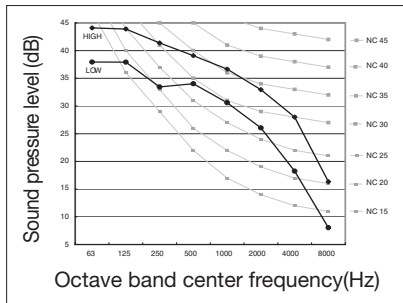

(5) AVXWNH071E*

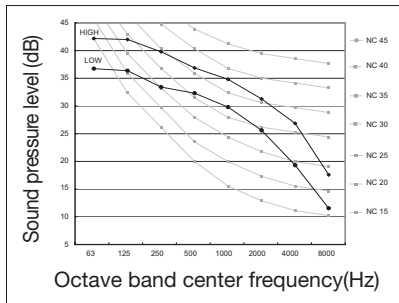

(6) ND022QHxEA

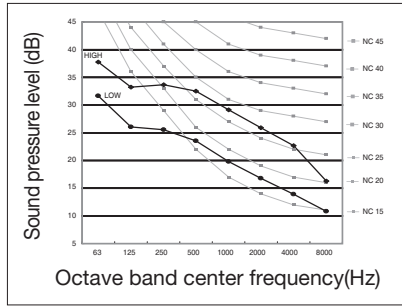

(7) ND028QHxEA

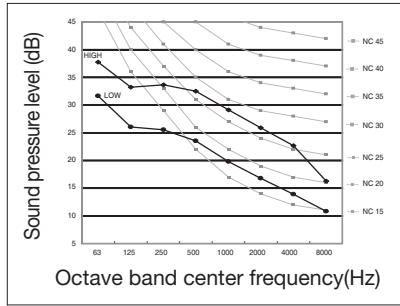

(8) ND036QHxEA

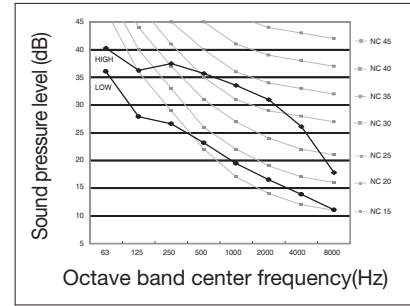

(9) ND045QHxEA

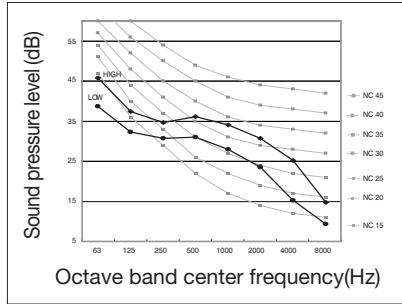

(10) ND056QHxEA

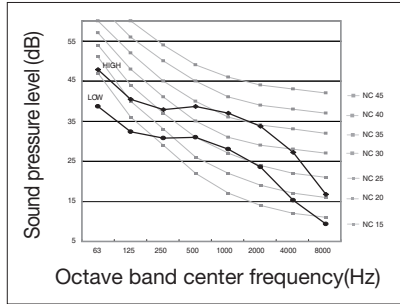

(11) ND071QHxEA

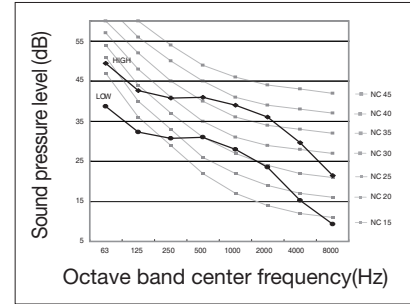

10 Neo Forte & Neo-Forte E

10-8. Temperature and air flow distribution

1) AVXWNH036E*, ND036QHXE*

(1) Cooling air velocity distribution

◆ Discharge angle : 60°

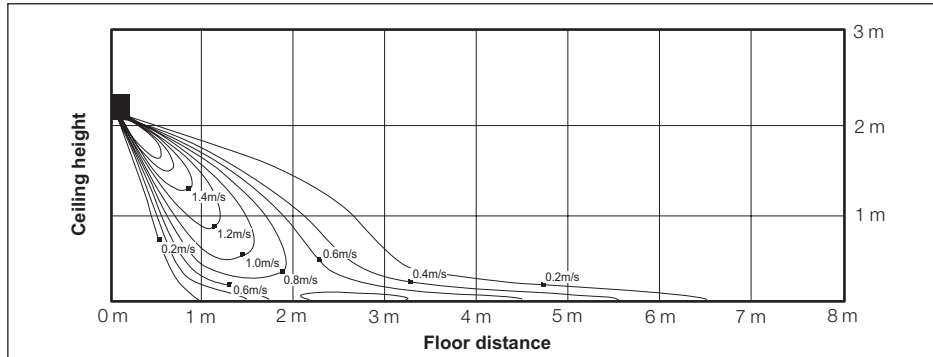

(2) Cooling temperature distribution

◆ Discharge angle : 60°

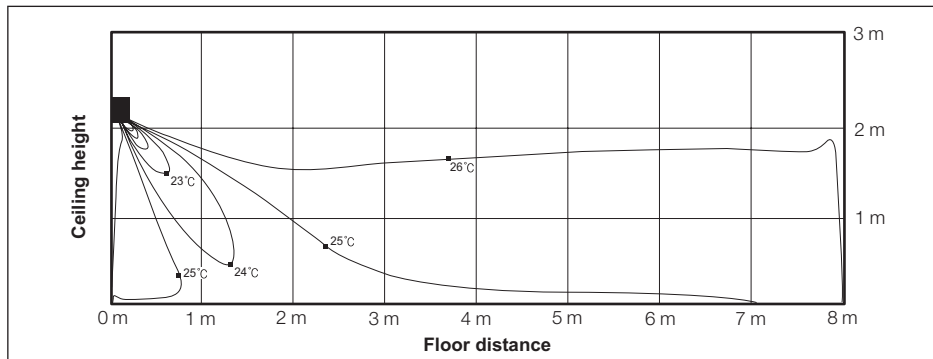

(3) Heating air velocity distribution

◆ Discharge angle : 60°

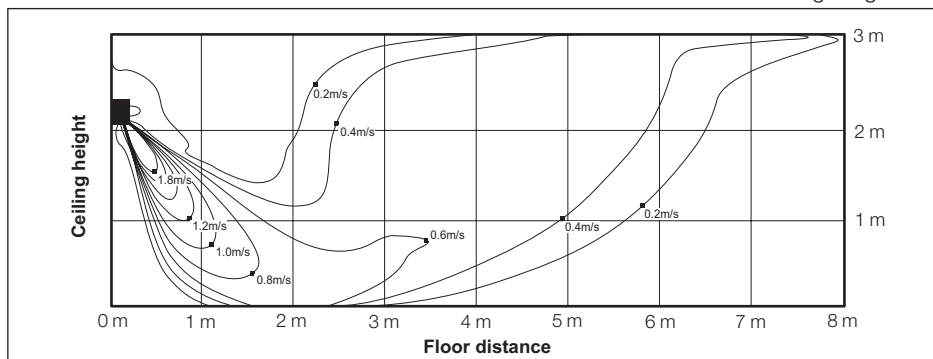

(4) Heating temperature distribution

◆ Discharge angle : 60°

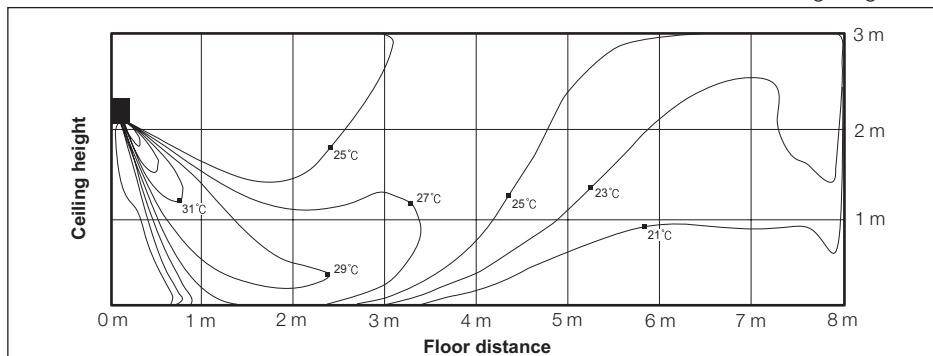

2) AVXWNH071E*, ND071QHXE*

(1) Cooling air velocity distribution

◆ Discharge angle : 60°

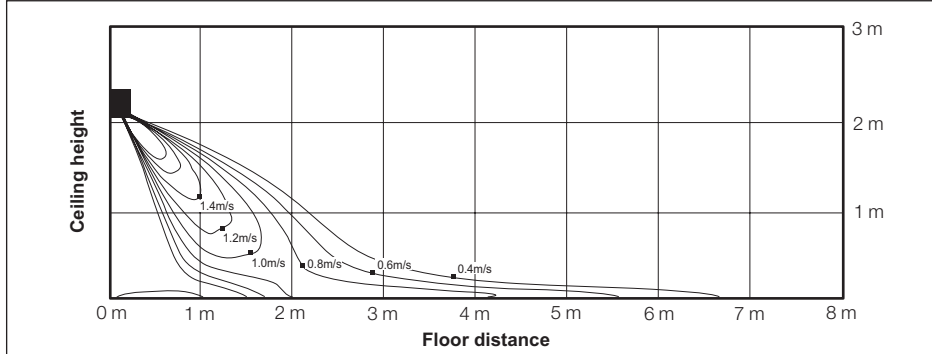

(2) Cooling temperature distribution

◆ Discharge angle : 60°

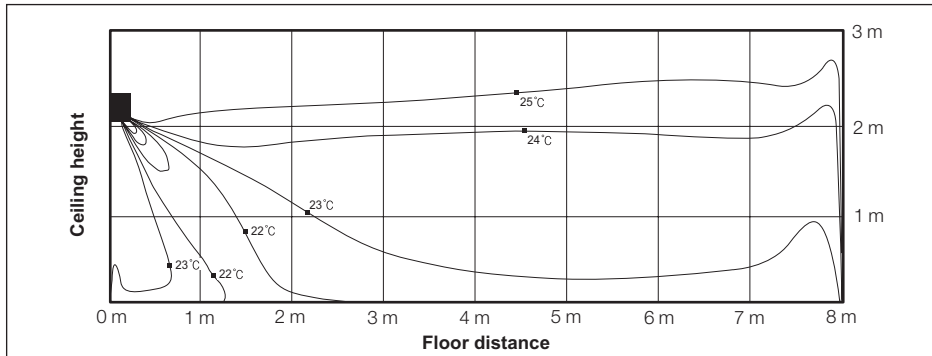

(3) Heating air velocity distribution

◆ Discharge angle : 60°

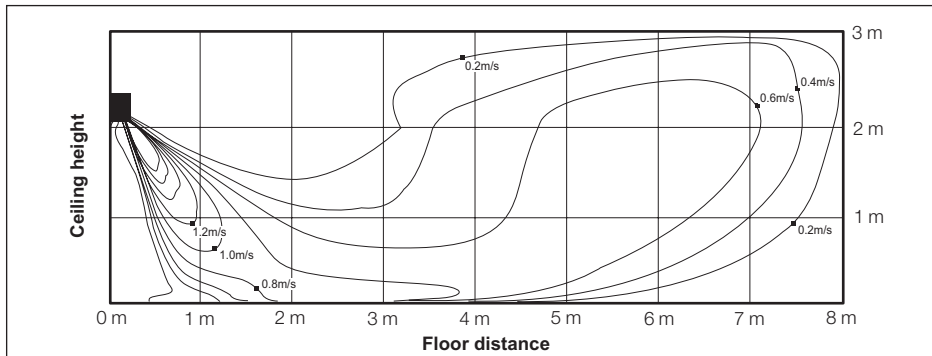

(4) Heating temperature distribution

◆ Discharge angle : 60°

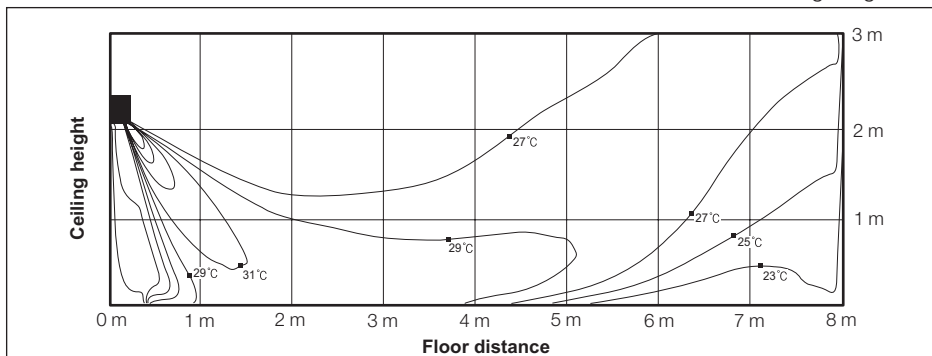



INDOOR UNIT



11 Vivace

(AVXWH***E*)

- 11-1. Specifications 144
- 11-2. Capacity tables 145
- 11-3. Dimensional drawing 147
- 11-4. PCB connector lay-out 149
- 11-5. Electrical wiring diagram 150
- 11-6. Sound pressure level 151
- 11-7. Temperature and air flow distribution 152

Optional Accessories

Individual Controllers



MWR-WE10



MWR-WH00



MWR-SH00



MR-DH00

Standard Accessories

Individual Controllers



11-1. Specifications

1) Technical specifications

Model			AVXVWH022E*	AVXVWH028E*	AVXVWH036E*	AVXVWH056E*	AVXVWH071E*	
Power Supply			Ø, #, V, Hz	1, 2, 220~240, 50	1, 2, 220~240, 50	1, 2, 220~240, 50	1, 2, 220~240, 50	1, 2, 220~240, 50
Mode*1)			-	HP / HR	HP / HR	HP / HR	HP / HR	HP / HR
Capacity (Nominal)	Cooling *2)	kW	2.2	2.8	3.6	5.6	6.8	
		Btu/h	7,500	9,600	12,300	19,100	23,200	
	Heating *3)	kW	2.5	3.2	4.0	6.3	7.0	
		Btu/h	8,500	10,900	13,600	21,500	23,900	
Power	Power Input (Nominal)	Cooling *2)	W	30	30	35	50	50
		Heating *3)	W	30	30	35	50	50
	Current Input (Nominal)	Cooling *2)	A	0.13	0.18	0.19	0.30	0.30
		Heating *3)	A	0.13	0.18	0.19	0.30	0.30
Fan	Motor	Type	-	Crossflow Fan / SSR	Crossflow Fan / SSR	Crossflow Fan / SSR	Crossflow Fan / SSR	Crossflow Fan / SSR
		Output	W	23	23	23	42	42
		Number of unit	EA	1	1	1	1	1
	Air Flow Rate	H/M/L (UL)	CMM	7 / 6 / 5	7.5 / 6.5 / 5.5	8.2 / 7.2 / 6.2	14 / 12 / 10	15 / 13 / 11
			CFM	250 / 210 / 180	260 / 230 / 190	290 / 250 / 220	490 / 420 / 350	530 / 460 / 390
	External Pressure	Min / Std / Max	mmAq	-	-	-	-	-
			Pa	-	-	-	-	-
WG			-	-	-	-	-	
Option Code			-	004602-1120E7-200000-300000	004602-1320E7-200000-300000	007602-15221A-200000-300000	005606-1A225E-200000-300000	005606-1C2371-200000-300000
Piping Connections	Liquid Pipe	Ø, mm	6.35	6.35	6.35	6.35	9.52	
		Ø, inch	1/4	1/4	1/4	1/4	3/8	
	Gas Pipe	Ø, mm	12.7	12.7	12.7	12.7	15.88	
		Ø, inch	1/2	1/2	1/2	1/2	5/8	
Drain Pipe	Ø, mm	ID18 Hose (OD, ID)	ID18 Hose (OD, ID)	ID18 Hose (OD, ID)	ID18 Hose (OD, ID)	ID18 Hose (OD, ID)		
Field Wiring	Power Source Wire	Below 20m / over 20m	mm ²	1.5 / 2.5	1.5 / 2.5	1.5 / 2.5	1.5 / 2.5	1.5 / 2.5
	Transmission Cable		mm ²	0.75 / 1.5	0.75 / 1.5	0.75 / 1.5	0.75 / 1.5	0.75 / 1.5
Refrigerant	Type	-	R410A	R410A	R410A	R410A	R410A	
	Control Method	-	EEV (External)	EEV (External)	EEV (External)	EEV (External)	EEV (External)	
Sound	Sound Pressure	High / Low *4)	dB(A)	31 / 21	31 / 21	35 / 21	40 / 30	41 / 30
Dimensions	Net Weight		kg	9	9	9	12	12
	Shipping Weight		kg	12	12	12	15	15
	Net Dimensions (WxHxD)		mm	825 x 285 x 189	825 x 285 x 189	825 x 285 x 189	1,065 x 298 x 218	1,065 x 298 x 218
	Shipping Dimensions (WxHxD)		mm	900 x 349 x 252	900 x 349 x 252	900 x 349 x 252	1,137 x 377 x 299	1,137 x 377 x 299
Panel Size	Panel model		-	-	-	-	-	
	Panel Net Weight		kg	-	-	-	-	
	Shipping Weight		kg	-	-	-	-	
	Net Dimensions (WxHxD)		mm	-	-	-	-	
	Shipping Dimensions (WxHxD)		mm	-	-	-	-	
Additional Accessories	Drain pump	Drain pump	- / Model	-	-	-	-	-
		Max. lifting Height / Displacement	mm/liter/h	-	-	-	-	-
	Air Filter		-	Long life filter	Long life filter	Long life filter	Long life filter	Long life filter

* Specifications may be subject to change without prior notice for product improvement.

*1) Mode

- HP : Heat Pump, HR : Heat Recovery

*2) Nominal cooling capacities are based on;

- Indoor temperature : 27°C DB, 19°C WB

- Outdoor temperature : 35°C DB, 24°C WB, Equivalent refrigerant piping : 7.5m, Level differences : 0m

*3) Nominal heating capacities are based on;

- Indoor temperature : 20°C DB, 15°C WB

- Outdoor temperature : 7°C DB, 6°C WB, Equivalent refrigerant piping : 7.5m, Level differences : 0m

*4) Sound pressure was acquired in a dead room. Thus actual noise level may be different depending on the installation conditions.

11-2. Capacity tables

1) Cooling

TC : Total Capacity(kW), SHC : Sensible Heat Capacity(kW)

Model	Outdoor temperature (°C, DB)	Indoor temperature (°C, WB)													
		20 (°C, DB)		23 (°C, DB)		26 (°C, DB)		27 (°C, DB)		28 (°C, DB)		30 (°C, DB)		32 (°C, DB)	
		14 (°C, WB)		16 (°C, WB)		18 (°C, WB)		19 (°C, WB)		20 (°C, WB)		22 (°C, WB)		24 (°C, WB)	
		TC	SHC	TC	SHC	TC	SHC	TC	SHC	TC	SHC	TC	SHC	TC	SHC
022	10	1.5	1.3	1.8	1.5	2.1	1.5	2.2	1.5	2.3	1.5	2.5	1.6	2.6	1.4
	12	1.5	1.3	1.8	1.5	2.1	1.5	2.2	1.5	2.3	1.5	2.5	1.6	2.6	1.4
	14	1.5	1.3	1.8	1.5	2.1	1.5	2.2	1.5	2.3	1.5	2.5	1.6	2.6	1.4
	16	1.5	1.3	1.8	1.5	2.1	1.5	2.2	1.5	2.3	1.5	2.4	1.5	2.6	1.4
	18	1.5	1.3	1.8	1.5	2.1	1.5	2.2	1.5	2.3	1.5	2.4	1.5	2.6	1.4
	20	1.5	1.3	1.8	1.5	2.1	1.5	2.2	1.5	2.3	1.5	2.4	1.5	2.6	1.4
	21	1.5	1.3	1.8	1.5	2.1	1.5	2.2	1.5	2.3	1.5	2.4	1.5	2.6	1.4
	23	1.5	1.3	1.8	1.5	2.1	1.5	2.2	1.5	2.3	1.5	2.4	1.5	2.6	1.4
	25	1.5	1.3	1.8	1.5	2.1	1.5	2.2	1.5	2.3	1.5	2.4	1.5	2.6	1.4
	27	1.5	1.3	1.8	1.5	2.1	1.5	2.2	1.5	2.3	1.5	2.4	1.5	2.6	1.4
	29	1.5	1.3	1.8	1.5	2.1	1.5	2.2	1.5	2.3	1.5	2.4	1.5	2.6	1.4
	31	1.5	1.3	1.8	1.5	2.1	1.5	2.2	1.5	2.3	1.5	2.4	1.5	2.6	1.4
	33	1.5	1.3	1.8	1.5	2.1	1.5	2.2	1.5	2.3	1.5	2.4	1.5	2.6	1.4
	35	1.5	1.3	1.8	1.5	2.1	1.5	2.2	1.5	2.3	1.5	2.4	1.5	2.6	1.4
	37	1.5	1.3	1.8	1.5	2.1	1.5	2.2	1.5	2.3	1.5	2.4	1.5	2.6	1.4
	39	1.5	1.3	1.8	1.5	2.1	1.5	2.2	1.5	2.3	1.5	2.4	1.5	2.5	1.3
42	1.5	1.3	1.8	1.5	2.1	1.5	2.1	1.4	2.2	1.4	2.3	1.5	2.4	1.2	
44	1.5	1.3	1.8	1.5	2.0	1.4	2.1	1.4	2.1	1.3	2.2	1.4	2.2	1.1	
028	10	1.9	1.6	2.3	1.8	2.6	2.0	2.8	1.9	2.9	1.9	3.1	1.9	3.4	1.9
	12	1.9	1.6	2.3	1.8	2.6	2.0	2.8	1.9	2.9	1.9	3.1	1.9	3.3	1.8
	14	1.9	1.6	2.3	1.8	2.6	2.0	2.8	1.9	2.9	1.9	3.1	1.9	3.3	1.8
	16	1.9	1.6	2.3	1.8	2.6	2.0	2.8	1.9	2.9	1.9	3.1	1.9	3.3	1.8
	18	1.9	1.6	2.3	1.8	2.6	2.0	2.8	1.9	2.9	1.9	3.1	1.9	3.3	1.8
	20	1.9	1.6	2.3	1.8	2.6	2.0	2.8	1.9	2.9	1.9	3.1	1.9	3.3	1.8
	21	1.9	1.6	2.3	1.8	2.6	2.0	2.8	1.9	2.9	1.9	3.1	1.9	3.3	1.8
	23	1.9	1.6	2.3	1.8	2.6	2.0	2.8	1.9	2.9	1.9	3.1	1.9	3.3	1.8
	25	1.9	1.6	2.3	1.8	2.6	2.0	2.8	1.9	2.9	1.9	3.1	1.9	3.3	1.8
	27	1.9	1.6	2.3	1.8	2.6	2.0	2.8	1.9	2.9	1.9	3.1	1.9	3.3	1.8
	29	1.9	1.6	2.3	1.8	2.6	2.0	2.8	1.9	2.9	1.9	3.1	1.9	3.3	1.8
	31	1.9	1.6	2.3	1.8	2.6	2.0	2.8	1.9	2.9	1.9	3.1	1.9	3.3	1.8
	33	1.9	1.6	2.3	1.8	2.6	2.0	2.8	1.9	2.9	1.9	3.1	1.9	3.3	1.8
	35	1.9	1.6	2.3	1.8	2.6	2.0	2.8	1.9	2.9	1.9	3.1	1.9	3.3	1.8
	37	1.9	1.6	2.3	1.8	2.6	2.0	2.8	1.9	2.9	1.9	3.1	1.9	3.3	1.8
	39	1.9	1.6	2.3	1.8	2.6	2.0	2.8	1.9	2.9	1.8	3.0	1.8	3.2	1.7
42	1.9	1.6	2.3	1.8	2.6	2.0	2.8	1.8	2.8	1.7	2.9	1.7	3.0	1.6	
44	1.9	1.6	2.3	1.8	2.5	1.9	2.7	1.7	2.7	1.6	2.7	1.6	2.8	1.5	
036	10	2.5	2.1	2.9	2.2	3.4	2.3	3.6	2.4	3.7	2.4	4.0	2.4	4.3	2.3
	12	2.5	2.1	2.9	2.2	3.4	2.3	3.6	2.4	3.7	2.4	4.0	2.4	4.3	2.3
	14	2.5	2.1	2.9	2.2	3.4	2.3	3.6	2.4	3.7	2.4	4.0	2.4	4.3	2.3
	16	2.5	2.1	2.9	2.2	3.4	2.3	3.6	2.4	3.7	2.4	4.0	2.4	4.3	2.3
	18	2.5	2.1	2.9	2.2	3.4	2.3	3.6	2.4	3.7	2.4	4.0	2.4	4.3	2.3
	20	2.5	2.1	2.9	2.2	3.4	2.3	3.6	2.4	3.7	2.4	4.0	2.4	4.3	2.3
	21	2.5	2.1	2.9	2.2	3.4	2.3	3.6	2.4	3.7	2.4	4.0	2.4	4.2	2.3
	23	2.5	2.1	2.9	2.2	3.4	2.3	3.6	2.4	3.7	2.4	4.0	2.4	4.2	2.3
	25	2.5	2.1	2.9	2.2	3.4	2.3	3.6	2.4	3.7	2.4	4.0	2.4	4.2	2.3
	27	2.5	2.1	2.9	2.2	3.4	2.3	3.6	2.4	3.7	2.4	4.0	2.4	4.2	2.3
	29	2.5	2.1	2.9	2.2	3.4	2.3	3.6	2.4	3.7	2.4	4.0	2.4	4.2	2.3
	31	2.5	2.1	2.9	2.2	3.4	2.3	3.6	2.4	3.7	2.4	4.0	2.4	4.2	2.3
	33	2.5	2.1	2.9	2.2	3.4	2.3	3.6	2.4	3.7	2.4	4.0	2.4	4.2	2.3
	35	2.5	2.1	2.9	2.2	3.4	2.3	3.6	2.4	3.7	2.4	4.0	2.4	4.2	2.3
	37	2.5	2.1	2.9	2.2	3.4	2.3	3.6	2.4	3.7	2.4	4.0	2.3	4.2	2.3
	39	2.5	2.1	2.9	2.2	3.4	2.3	3.6	2.4	3.7	2.4	4.0	2.3	4.1	2.2
42	2.5	2.1	2.9	2.2	3.4	2.3	3.5	2.3	3.6	2.3	3.9	2.2	3.9	2.1	
44	2.5	2.1	2.9	2.2	3.2	2.2	3.4	2.2	3.5	2.2	3.7	2.1	3.6	1.9	
056	10	3.9	3.0	4.6	3.4	5.3	3.7	5.6	3.8	5.8	3.8	6.3	3.9	6.7	3.6
	12	3.9	3.0	4.6	3.4	5.3	3.7	5.6	3.8	5.8	3.8	6.3	3.9	6.7	3.6
	14	3.9	3.0	4.6	3.4	5.3	3.7	5.6	3.8	5.8	3.8	6.2	3.8	6.7	3.6
	16	3.9	3.0	4.6	3.4	5.3	3.7	5.6	3.8	5.8	3.8	6.2	3.8	6.6	3.5
	18	3.9	3.0	4.6	3.4	5.3	3.7	5.6	3.8	5.8	3.8	6.2	3.8	6.6	3.5
	20	3.9	3.0	4.6	3.4	5.3	3.7	5.6	3.8	5.8	3.8	6.2	3.8	6.6	3.5
	21	3.9	3.0	4.6	3.4	5.3	3.7	5.6	3.8	5.8	3.8	6.2	3.8	6.6	3.5
	23	3.9	3.0	4.6	3.4	5.3	3.7	5.6	3.8	5.8	3.8	6.2	3.8	6.6	3.5
	25	3.9	3.0	4.6	3.4	5.3	3.7	5.6	3.8	5.8	3.8	6.2	3.8	6.6	3.5
	27	3.9	3.0	4.6	3.4	5.3	3.7	5.6	3.8	5.8	3.8	6.2	3.8	6.6	3.5
	29	3.9	3.0	4.6	3.4	5.3	3.7	5.6	3.8	5.8	3.8	6.2	3.8	6.6	3.5
	31	3.9	3.0	4.6	3.4	5.3	3.7	5.6	3.8	5.8	3.8	6.2	3.8	6.6	3.5
	33	3.9	3.0	4.6	3.4	5.3	3.7	5.6	3.8	5.8	3.8	6.2	3.8	6.6	3.5
	35	3.9	3.0	4.6	3.4	5.3	3.7	5.6	3.8	5.8	3.8	6.2	3.8	6.6	3.5
	37	3.9	3.0	4.6	3.4	5.3	3.7	5.6	3.8	5.8	3.8	6.1	3.7	6.5	3.4
	39	3.9	3.0	4.6	3.4	5.3	3.7	5.6	3.8	5.8	3.8	6.1	3.7	6.4	3.3
42	3.9	3.0	4.6	3.4	5.3	3.7	5.4	3.7	5.6	3.7	5.8	3.6	6.0	3.2	
44	3.9	3.0	4.6	3.4	5.0	3.6	5.3	3.6	5.4	3.6	5.5	3.5	5.6	3.0	
071	10	4.7	3.7	5.5	4.1	6.4	4.5	6.8	4.6	7.1	4.6	7.6	4.6	8.2	4.4
	12	4.7	3.7	5.5	4.1	6.4	4.5	6.8	4.6	7.1	4.6	7.6	4.6	8.1	4.3
	14	4.7	3.7	5.5	4.1	6.4	4.5	6.8	4.6	7.1	4.6	7.6	4.6	8.1	4.3
	16	4.7	3.7	5.5	4.1	6.4	4.5	6.8	4.6	7.1	4.6	7.6	4.6	8.1	4.3
	18	4.7	3.7	5.5	4.1	6.4	4.5	6.8	4.6	7.0	4.6	7.5	4.5	8.0	4.2
	20	4.7	3.7	5.5	4.1	6.4	4.5	6.8	4.6	7.0	4.6	7.5	4.5	8.0	4.2
	21	4.7	3.7	5.5	4.1	6.4	4.5	6.8	4.6	7.0	4.6	7.5	4.5	8.0	4.2
	23	4.7	3.7	5.5	4.1	6.4	4.5	6.8	4.6	7.0	4.6	7.5	4.5	8.0	4.2
	25	4.7	3.7	5.5	4.1	6.4	4.5	6.8	4.6	7.0	4.6	7.5	4.5	8.0	4.2
	27	4.7	3.7	5.5	4.1	6.4	4.5	6.8	4.6	7.0	4.6	7.5	4.5	8.0	4.2
	29	4.7	3.7	5.5	4.1	6.4	4.5	6.8	4.6	7.0	4.6	7.5	4.5	8.0	4.2
	31	4.7	3.7	5.5	4.1	6.4	4.5	6.8	4.6	7.0	4.6	7.5	4.5	8.0	4.2
	33	4.7	3.7	5.5	4.1	6.4	4.5	6.8	4.6	7.0	4.6	7.5	4.5	8.0	4.2
	35	4.7	3.7	5.5	4.1	6.4	4.5	6.8	4.6	7.0	4.6	7.5	4.5	8.0	4.2
	37	4.7	3.7	5.5	4.1	6.4	4.5	6.8	4.6	7.0	4.6	7.5	4.5	7.9	4.1
	39	4.7	3.7	5.5	4.1	6.4	4.5	6.8	4.6	7.0	4.6	7.4	4.4	7.7	4.0
42	4.7	3.7	5.5	4.1	6.4	4.5	6.6	4.5	6.7	4.4	7.0	4.2	7.3	3.8	
44	4.7	3.7	5.5	4.1	6.1	4.4	6.5	4.4	6.5	4.3	6.7	4.1	6.8	3.6	

Indoor units

11 Vivace

11-2. Capacity tables

2) Heating

TC : Total Capacity(kW)

Model	Outdoor temperature (°C)		Indoor temperature (°C, DB)				
			16.0	18.0	20.0	22.0	24.0
	DB	WB	TC	TC	TC	TC	TC
022	-20	-21	1.5	1.5	1.5	1.5	1.5
	-17	-18	1.6	1.6	1.6	1.6	1.6
	-15	-16	1.7	1.6	1.6	1.6	1.6
	-12	-13	1.8	1.8	1.8	1.8	1.7
	-10	-11	2.0	2.0	1.9	1.9	1.9
	-7	-8	2.3	2.2	2.2	2.0	2.0
	-5	-6	2.4	2.3	2.3	2.2	2.2
	-3	-4	2.5	2.5	2.4	2.3	2.2
	0	-1	2.6	2.5	2.5	2.3	2.2
	3	2.2	2.7	2.6	2.5	2.3	2.2
	5	4.1	2.8	2.7	2.5	2.3	2.2
	7	6	2.8	2.7	2.5	2.3	2.2
	9	7.9	3.0	2.7	2.5	2.3	2.2
	11	9.8	3.0	2.7	2.5	2.3	2.2
	13	12	3.0	2.7	2.5	2.3	2.2
15	14	3.0	2.7	2.5	2.3	2.2	
028	-20	-21	1.9	1.9	1.9	1.9	1.9
	-17	-18	2.0	2.0	2.0	2.0	1.9
	-15	-16	2.1	2.1	2.0	2.0	1.9
	-12	-13	2.2	2.2	2.2	2.1	2.1
	-10	-11	2.3	2.3	2.3	2.3	2.2
	-7	-8	2.5	2.4	2.4	2.4	2.3
	-5	-6	2.6	2.6	2.5	2.5	2.4
	-3	-4	2.8	2.7	2.7	2.6	2.5
	0	-1	2.9	2.8	2.8	2.7	2.6
	3	2.2	3.0	3.0	2.9	2.8	2.7
	5	4.1	3.2	3.1	3.1	2.9	2.7
	7	6	3.3	3.2	3.2	3.0	2.7
	9	7.9	3.4	3.3	3.2	3.0	2.7
	11	9.8	3.5	3.3	3.2	3.0	2.7
	13	12	3.6	3.4	3.2	3.0	2.7
15	14	3.7	3.4	3.2	3.0	2.7	
036	-20	-21	2.4	2.4	2.3	2.3	2.3
	-17	-18	2.6	2.5	2.4	2.4	2.3
	-15	-16	2.7	2.6	2.5	2.5	2.4
	-12	-13	2.8	2.7	2.7	2.6	2.6
	-10	-11	2.9	2.9	2.9	2.8	2.8
	-7	-8	3.1	3.1	3.0	3.0	2.9
	-5	-6	3.3	3.2	3.2	3.1	3.0
	-3	-4	3.4	3.4	3.3	3.2	3.1
	0	-1	3.6	3.6	3.5	3.4	3.2
	3	2.2	3.8	3.7	3.7	3.5	3.4
	5	4.1	3.9	3.9	3.8	3.6	3.4
	7	6	4.1	4.1	4.0	3.7	3.4
	9	7.9	4.2	4.1	4.0	3.7	3.4
	11	9.8	4.4	4.2	4.0	3.7	3.4
	13	12	4.5	4.2	4.0	3.7	3.4
15	14	4.6	4.3	4.0	3.7	3.4	
056	-20	-21	3.9	3.8	3.8	3.7	3.7
	-17	-18	4.0	4.0	3.9	3.8	3.8
	-15	-16	4.2	4.1	4.0	3.9	3.8
	-12	-13	4.4	4.3	4.2	4.2	4.1
	-10	-11	4.6	4.6	4.5	4.4	4.4
	-7	-8	4.9	4.8	4.8	4.7	4.5
	-5	-6	5.2	5.1	5.0	4.9	4.7
	-3	-4	5.4	5.3	5.3	5.1	4.9
	0	-1	5.7	5.6	5.5	5.3	5.0
	3	2.2	5.9	5.9	5.8	5.6	5.3
	5	4.1	6.2	6.1	6.0	5.7	5.3
	7	6	6.5	6.4	6.3	5.8	5.3
	9	7.9	6.7	6.5	6.3	5.8	5.3
	11	9.8	6.9	6.6	6.3	5.8	5.3
	13	12	7.1	6.7	6.3	5.8	5.3
15	14	7.3	6.8	6.3	5.8	5.3	
071	-20	-21	4.4	4.3	4.2	4.2	4.2
	-17	-18	4.5	4.4	4.3	4.3	4.2
	-15	-16	4.7	4.6	4.4	4.3	4.2
	-12	-13	4.9	4.8	4.7	4.6	4.5
	-10	-11	5.1	5.1	5.0	4.9	4.9
	-7	-8	5.4	5.4	5.3	5.2	5.1
	-5	-6	5.7	5.6	5.6	5.4	5.2
	-3	-4	6.0	5.9	5.9	5.6	5.4
	0	-1	6.3	6.2	6.1	5.9	5.6
	3	2.2	6.6	6.5	6.4	6.2	5.9
	5	4.1	6.9	6.8	6.7	6.3	5.9
	7	6	7.2	7.1	7.0	6.5	5.9
	9	7.9	7.4	7.2	7.0	6.5	5.9
	11	9.8	7.6	7.3	7.0	6.5	5.9
	13	12	7.9	7.4	7.0	6.5	5.9
15	14	8.1	7.5	7.0	6.5	5.9	

11-3. Dimensional drawing

1) AVXWVH022/028/036E*

Unit:mm

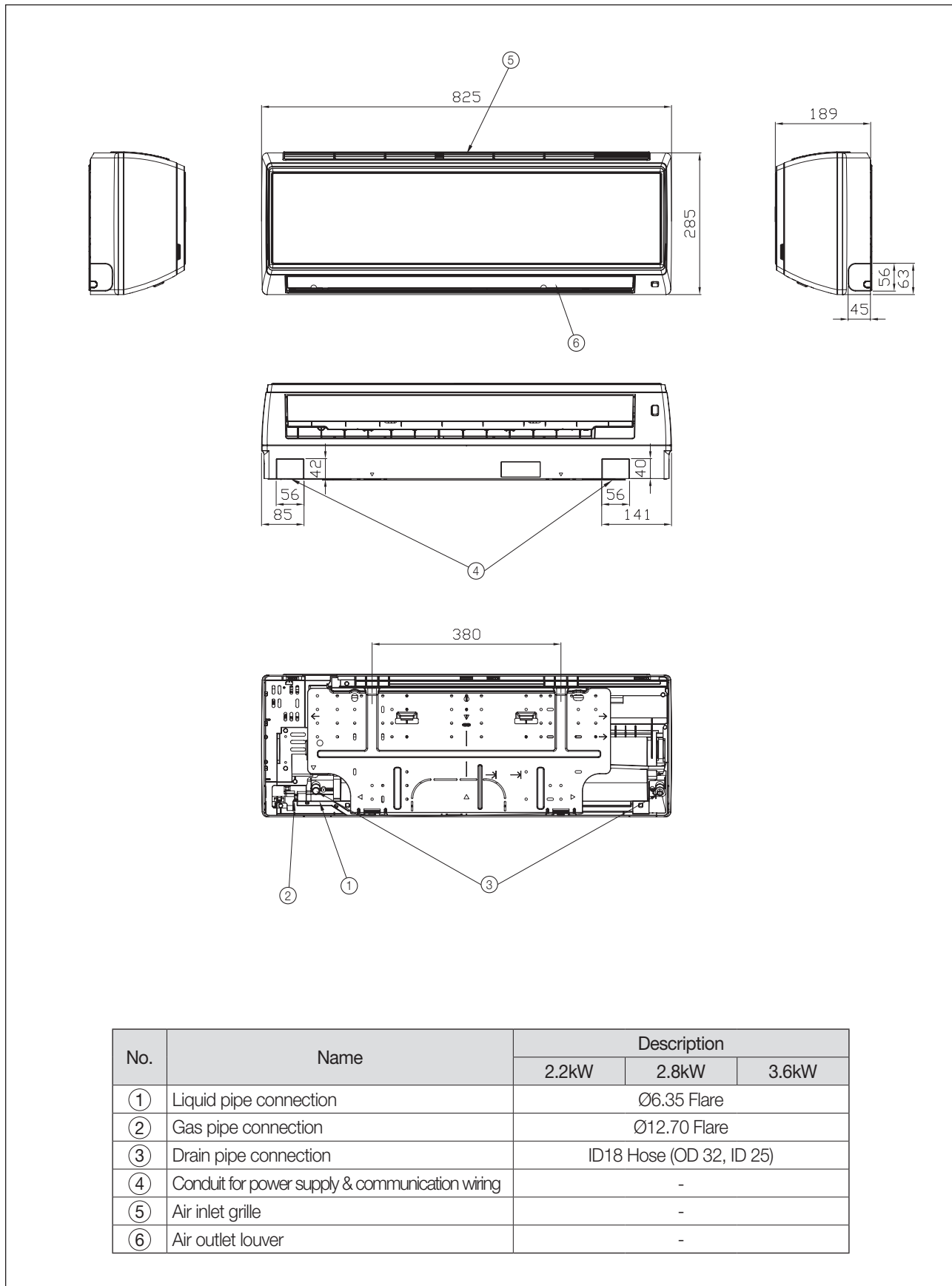

Indoor units

11 Vivace

11-3. Dimensional drawing

2) AVXWVH056/071E*

Unit:mm

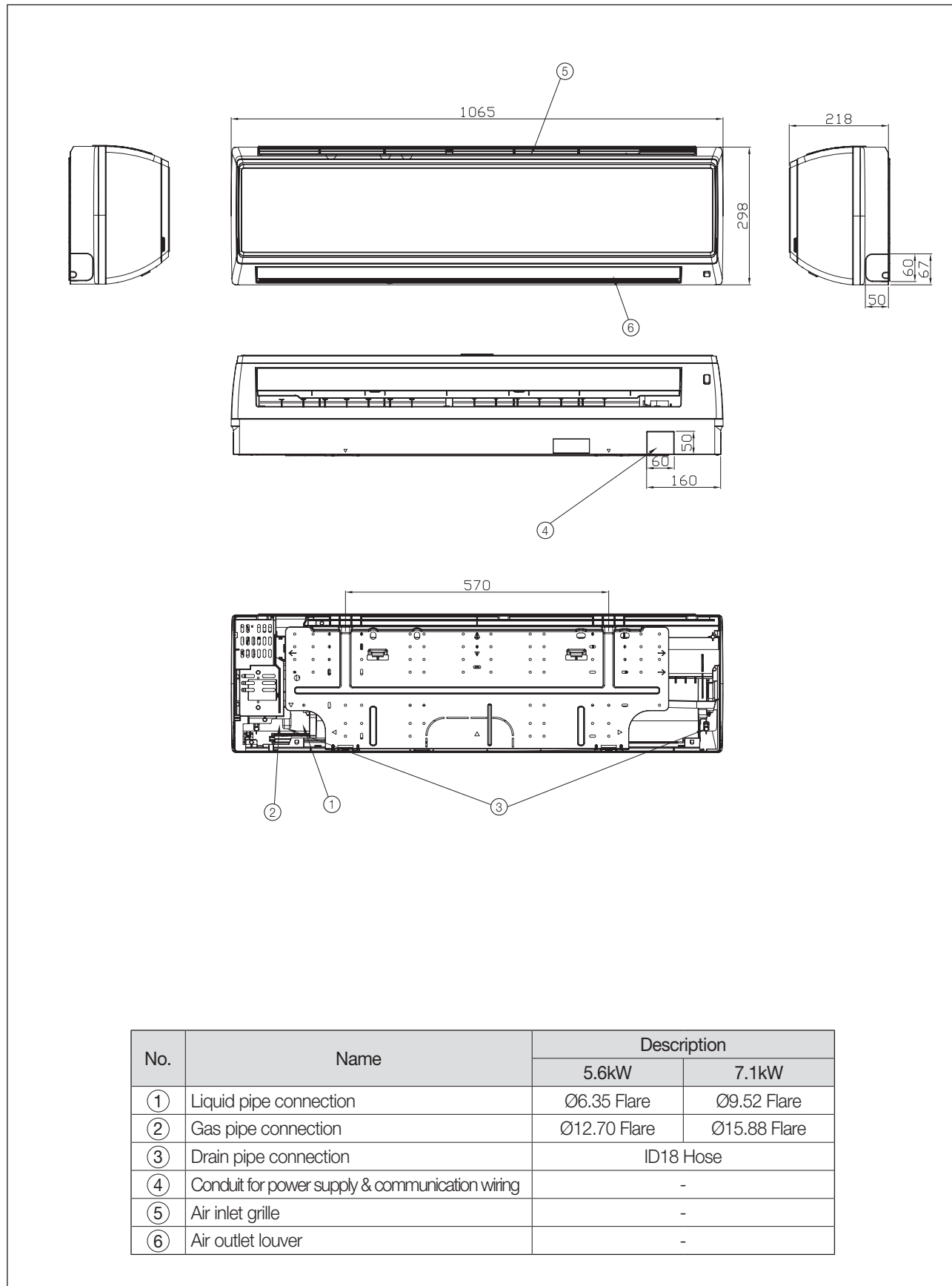

11-4. PCB Connector Lay-out

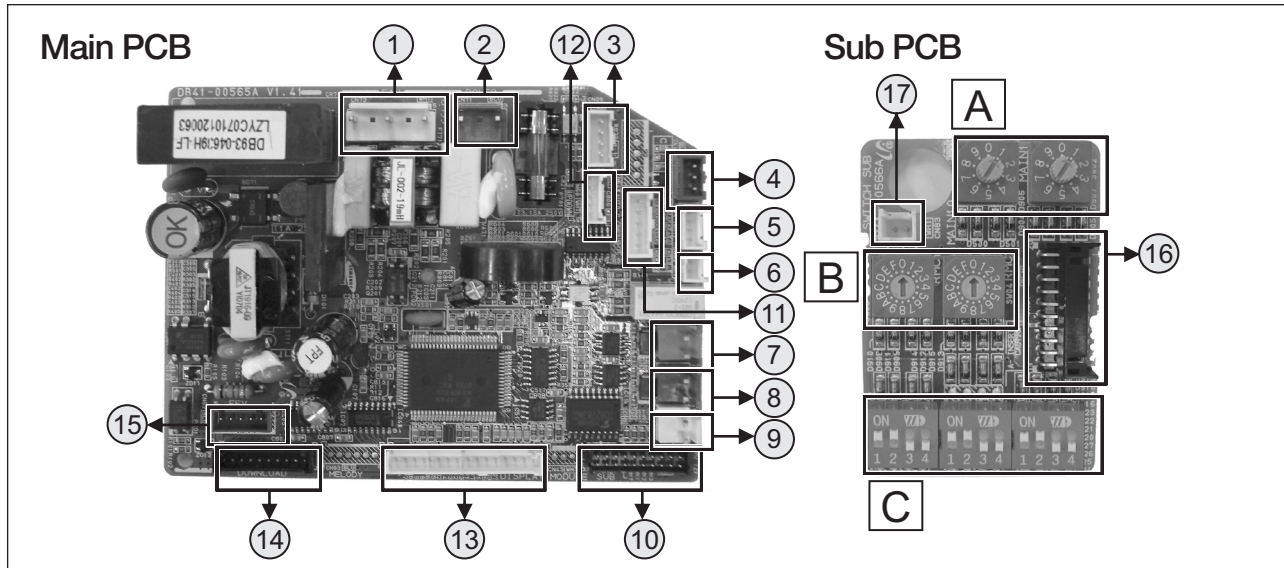

Indoor units

Main PCB			
No.	CN #	COLOR	FUNCTION
①	CN73	White	Fan Motor
②	CN71	Blue	AC 230V Input
③	CN86	Yellow	MPI
④	CN44	Blue	Hall IC
⑤	CN41	White	Room Sensor, Eva-In Sensor
⑥	CN42	White	Eva-Out Sensor
⑦	CN31	Red	Communication with Outdoor Units (COM1)
⑧	CN33	Blue	Communication with Wired Remote Controller (COM2)
⑨	CN32	White	DC 12V for Wired remote controller
⑩	CN61	Black	Main-Sub PCB connector
⑪	CN63	White	Auto Grille Motor
⑫	CN60	White	Up&Down Stepping Motor
⑬	CN91	White	Display, Wireless Remote Controller Button & Module
⑭	CN10	Black	MICOM Download
⑮	CN62	Blue	EEV

Sub PCB			
No.	CN #	COLOR	FUNCTION
⑯	CN61	Black	Main-Sub PCB connector
⑰	CN83	White	External Contact Control

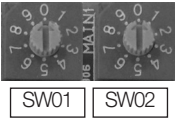
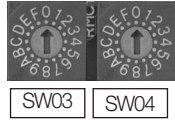
No.	S/W	FUNCTION	
A		Main Address Setting (00~63)	
B		SW03	SW04
		Address of Interface Module Channel 0~2	
		Group Address (RMC) for Centralized Control 0~F	

No.	S/W	FUNCTION	ON	OFF
C	K1	-	-	-
	K2	Centralized Controller	Not use	Use
	K3	RPM Up	N/A	N/A
	K4	Optional Drain Pump	N/A	N/A
	K5	Heating Thermo-off	+2°C	+5°C
	K6	Filter Signal Display	1,000hrs	2,000hrs
	K7	Hot Water Coil	N/A	N/A
	K8	Electrical Heater	N/A	N/A
	K9	Min. EEV Step at Heating	Fixed 80 step	0 or 80 step
	K10	Priority of Indoor unit Display on Wired Remote Control	Slave (Default)	Master
	K11	External Contact Control	Not use	Use
	K12	-	-	-

11 Vivace

11-5. Electrical wiring diagram

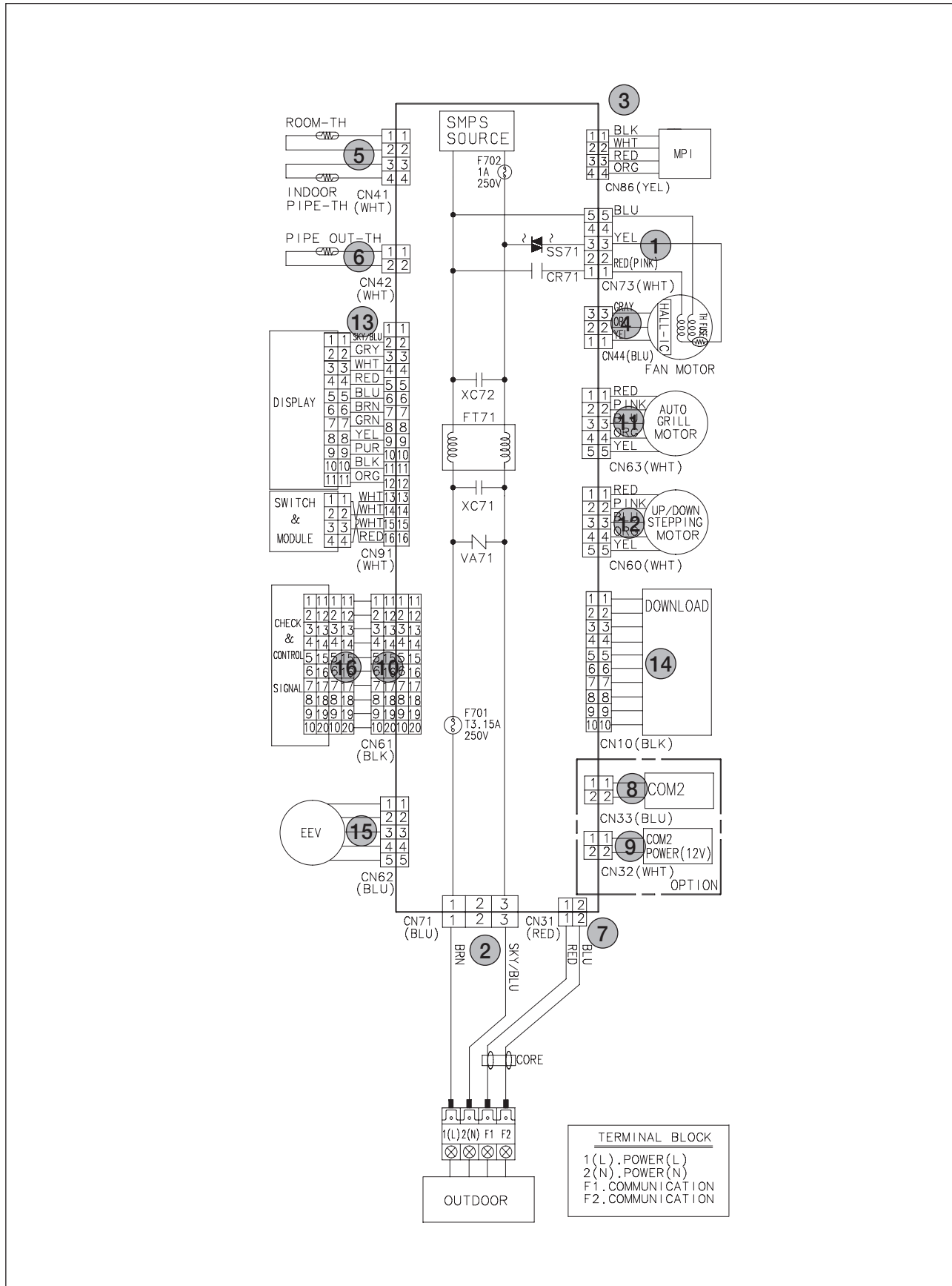

11-6. Sound pressure level

1) Operation sound level

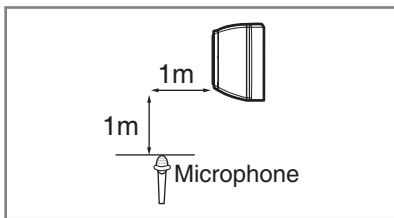

Unit : dB(A)

Model	High	Low
AVXWWH022E*	31	21
AVXWWH028E*	31	21
AVXWWH036E*	35	21
AVXWWH056E*	40	30
AVXWWH071E*	41	30

Note

- ◆ These operation values were obtained in a dead room. Sound pressure level will vary depending on a range of factors such as the construction of the particular room where the equipment is installed.
- ◆ Operation sound level may differ depending on operation and ambient conditions.

2) NC curves

(1) AVXWWH022E*

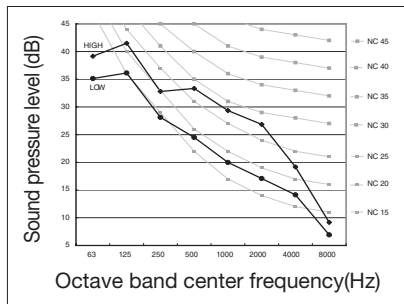

(2) AVXWWH028E*

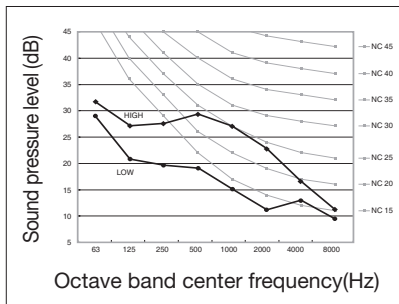

(3) AVXWWH036E*

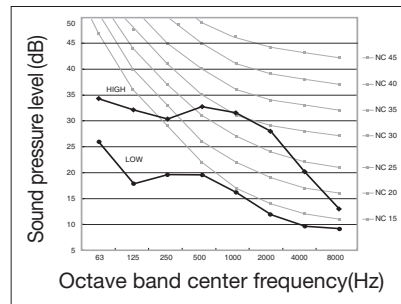

(4) AVXWWH056E*

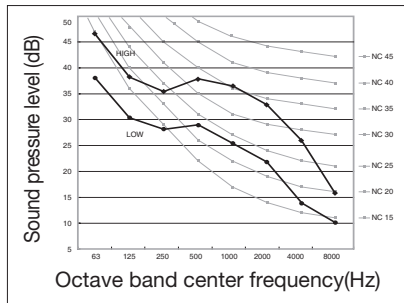

(5) AVXWWH071E*

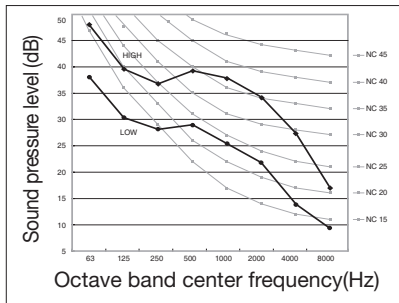

11 Vivace

11-7. Temperature and air flow distribution

1) AVXWVH036E*

(1) Cooling air velocity distribution

◆ Discharge angle : 60°

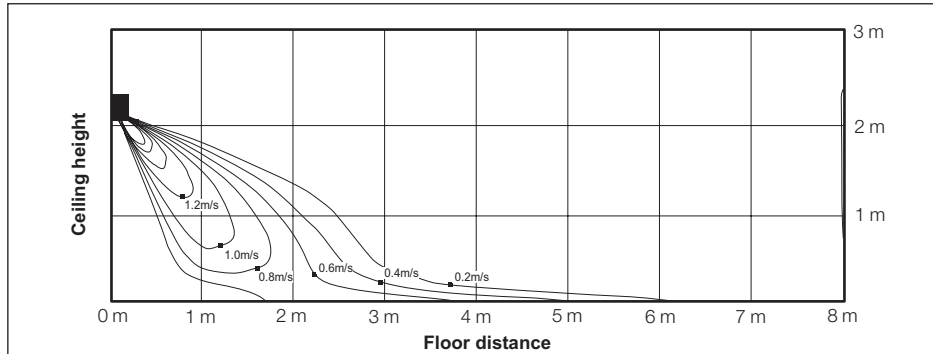

(2) Cooling temperature distribution

◆ Discharge angle : 60°

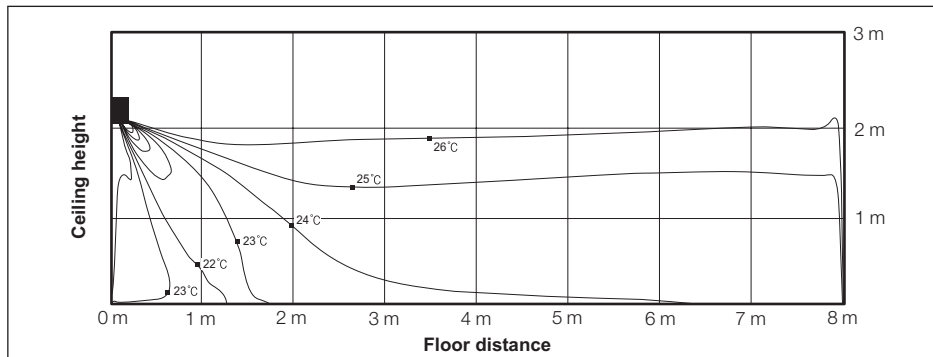

(3) Heating air velocity distribution

◆ Discharge angle : 60°

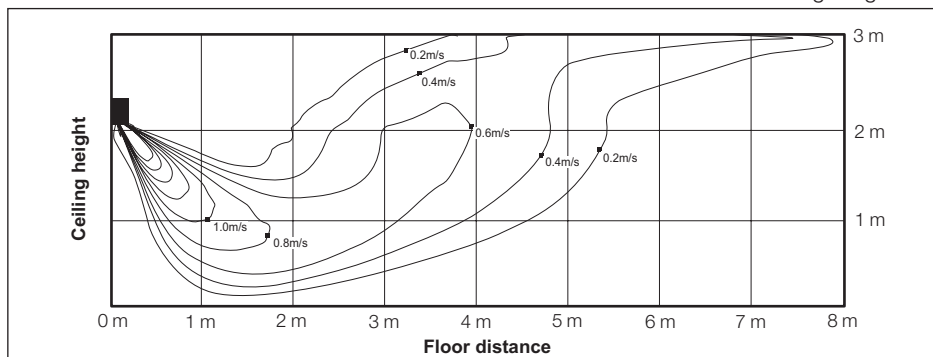

(4) Heating temperature distribution

◆ Discharge angle : 60°

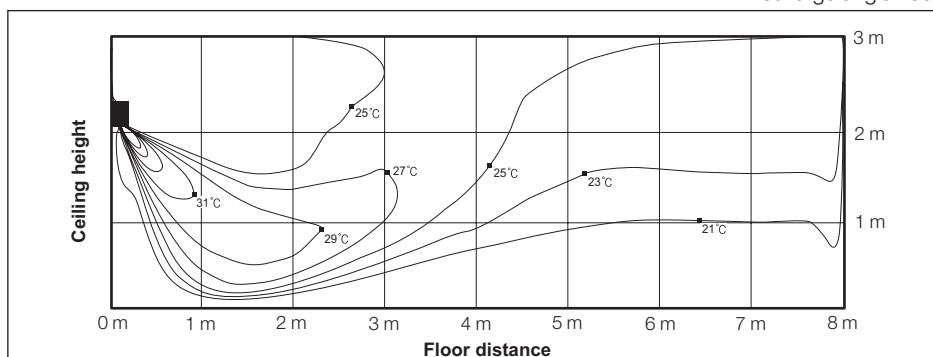

2) AVXWH071E*

(1) Cooling air velocity distribution

◆ Discharge angle : 60°

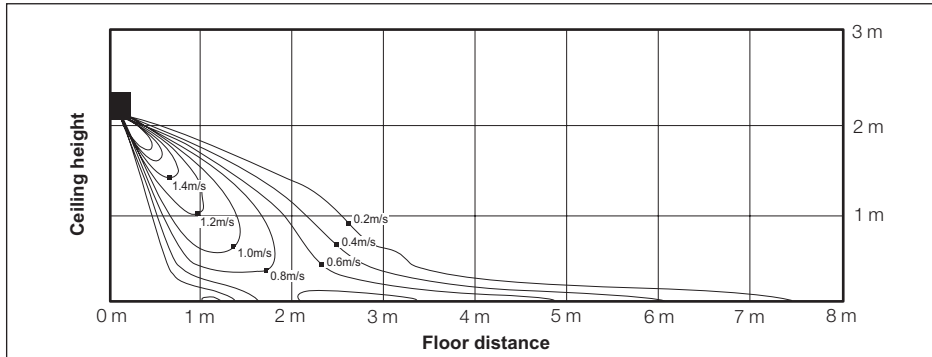

(2) Cooling temperature distribution

◆ Discharge angle : 60°

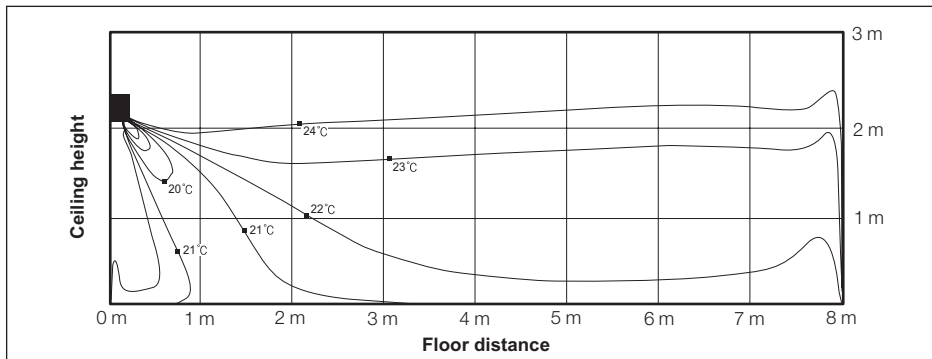

(3) Heating air velocity distribution

◆ Discharge angle : 60°

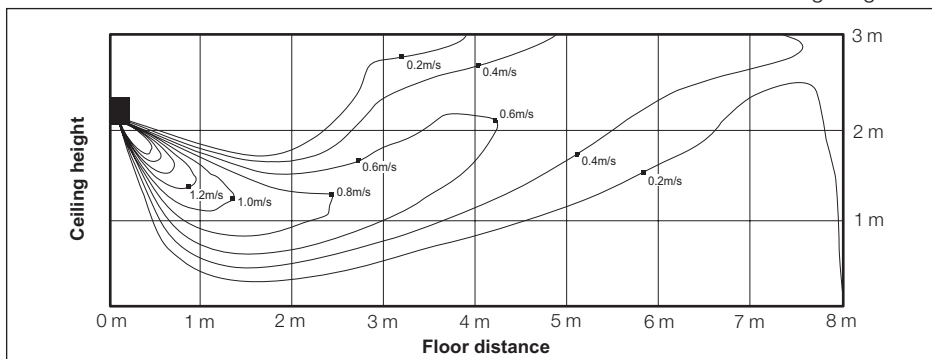

(4) Heating temperature distribution

◆ Discharge angle : 60°

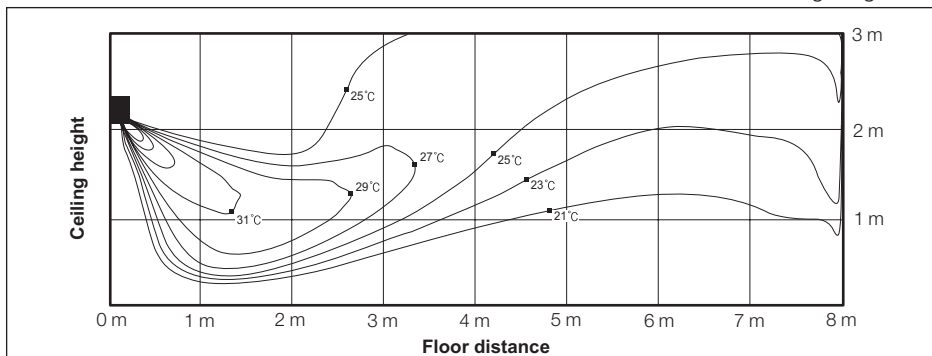



DVM PLUS IV

III. VENTILATION

1 ERV PLUS	157
-------------------------	-----

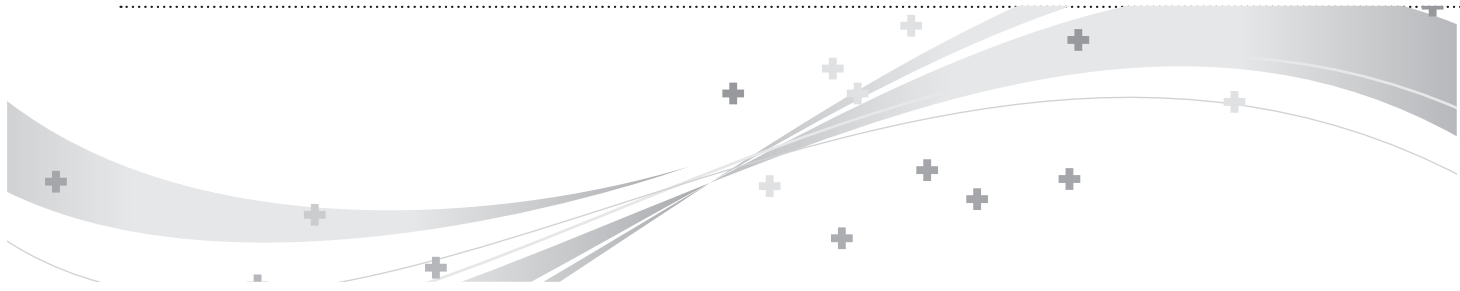

Energy Recovery Ventilation



1 ERV PLUS

(RHF***KHEA)

1-1. Specifications.....	158
1-2. Capacity tables	159
1-3. Dimensional drawing.....	160
1-4. PCB connector lay-out.....	161
1-5. Electrical wiring diagram	162
1-6. Sound pressure level	163
1-7. Recommended operation range	164

Optional Accessories

Individual Controllers



MMR-WE10

Humidifier



MVO-VA500100
MVO-VA100100

S-Plasma ion kit



MSD-EAN1

CO₂ sensor



MCS-C1

1 ERV PLUS

1-1. Specifications

1) Technical specifications

*Refer to following capacities when using the product with outdoor unit: RHF050KHEA : 3.6kW , RHF100KHEA : 7.1 kW

Model				RHF050KHEA	RHF100KHEA	
Power Supply			Ø, #, V, Hz	1, 2, 220~240, 50	1, 2, 220~240, 50	
Performance	Temp. Exchange Efficiency	Cooling	Turbo	-	70	70
			high	-	70	70
			low	-	74	74
		Heating	Turbo	-	75	75
			high	-	75	75
			low	-	79	79
	Effective Enthalpy Exchange Efficiency	Cooling	Turbo	-	60	62
			high	-	60	62
			low	-	66	68
		Heating	Turbo	-	73	75
			high	-	73	75
			low	-	79	81
Outside Air Processing Capacity		Cooling *1) (DX Coil/Element)	-	5.1(3.6/1.5)	11.5(7.1/3.4)	
		Heating *2) (DX Coil/Element)	-	6.5(4.0/2.5)	13.2(8.0/5.2)	
Fan	Airflow rate		Turbo/High/Low(UL)	CMH	500/500/360	1000/1000/690
				CFM	294/294/211	588/588/406
	External Static pressure		Turbo/High/Low	mmAq	16.3/10.2/8.7	15.3/9.2/7.6
				Pa	160/100/85	150/90/75
	Motor		Type	-	BLDC	BLDC
			Output	W	180	70
Power	Power Input		Turbo	W	220	510
			high		140	350
			low		90	235
	Current Input		Turbo	A	1.70	3.70
			high		1.00	2.40
			low		0.60	1.60
Option Code			-	015617152380	0156171C2373	
Piping Connections	Liquid Pipe		Ø, mm	6.35	6.35	
			Ø, inch	1/4	1/4	
	Gas Pipe		Ø, mm	12.7	12.7	
			Ø, inch	1/2	1/2	
	Drain Pipe		Ø, mm	VP25 (OD32, ID25)	VP25 (OD32, ID25)	
			Ø, inch	VP25 (OD 1-1/4", ID 1")	VP25 (OD 1-1/4", ID 1")	
Water Supply		Ø, mm	12.7	12.7		
		Ø, inch	1/2	1/2		
Field Wiring	Power Source Wire		mm ²	1.5/2.5	1.5/2.5	
	Transmission Cable		mm ²	0.75 / 1.5	0.75 / 1.5	
Refrigerant	Type		-	R410A	R410A	
	Control Method		-	EEV	EEV	
Sound Pressure	Sound Level*4)	Turbo / High / Low	dBA	38.5/36/32	40.5/38/35	
Dimensions	Net Weight		kg	61.0	90.0	
	Shipping Weight		kg	75.2	107.5	
	Net Dimensions (W×H×D)		mm	1,553 x 270 x 1,000	1,763 x 340 x 1,135	
	Shipping Dimensions (W×H×D)		mm	1,847 x 349 x 1,300	2,027 x 428 x 1,424	
	Supply/Return/Exhaust/Outside Duct Flange (Ø)		mm	200	250	
Accessory	Air Filter		-	High Efficiency Filter(PP)	High Efficiency Filter(PP)	
Optional Accessory	Humidifier*3)		Type	Natural Evaporating Type	Natural Evaporating Type	
			Qty	EA	1	
			Amount	kg/h	2.7	
			Pressure Feed Water	MPa	0.02~0.49	
	S-Plasma ion kit		-	MSD-EAN1	MSD-EAN1	
	CO ₂ sensor		-	MOS-C1	MOS-C1	
Humidity Sensor		-	Option	Option		
Ambient Condition	Around Unit		-	0~40°C DB, 80%RH or less	0~40°C DB, 80%RH or less	
	OA *5)		-	-15~40°C DB, 80%RH or less	-15~40°C DB, 80%RH or less	
	RA *5)		-	0~40°C DB, 80%RH or less	0~40°C DB, 80%RH or less	

* Specifications may be subject to change without prior notice for product improvement.

*1) Nominal cooling capacities are based on;

- Indoor temperature : 27°C DB, 19°C WB - Outdoor temperature : 35°C DB, 24°C WB, Equivalent refrigerant piping : 7.5m, Level differences : 0m

*2) Nominal heating capacities are based on;

- Indoor temperature : 20°C DB, 15°C WB

- Outdoor temperature : 7°C DB, 6°C WB, Equivalent refrigerant piping : 7.5m, Level differences : 0m

*3) Humidifying capacity is based on;

- Indoor temperature : 20°C DB, 15°C WB

- Outdoor temperature : 7°C DB, 6°C WB, Equivalent refrigerant piping : 7.5m, Level differences : 0m

*4) Sound pressure was acquired in a dead room. Thus actual noise level may be different depending on the installation conditions.

*5) OA: fresh air from outdoor. RA: return air from room.

1-2. Capacity tables

1) Cooling

TC : Total Capacity(kW), SHC : Sensible Heat Capacity(kW)

Model	Outdoor temperature (°C)		Indoor temperature													
			20 (°C, DB) 14 (°C, WB)		23 (°C, DB) 16 (°C, WB)		26 (°C, DB) 18 (°C, WB)		27 (°C, DB) 19 (°C, WB)		28 (°C, DB) 20 (°C, WB)		30 (°C, DB) 22 (°C, WB)		32 (°C, DB) 24 (°C, WB)	
	DB	WB	TC	SHC	TC	SHC	TC	SHC	TC	SHC	TC	SHC	TC	SHC	TC	SHC
500	10	4	2.5	2.2	2.9	2.5	3.4	2.7	3.6	2.8	3.7	2.8	4.0	2.8	4.3	2.7
	12	5.5	2.5	2.2	2.9	2.5	3.4	2.7	3.6	2.8	3.7	2.8	4.0	2.8	4.3	2.7
	14	7	2.5	2.2	2.9	2.5	3.4	2.7	3.6	2.8	3.7	2.8	4.0	2.8	4.3	2.7
	16	8.5	2.5	2.2	2.9	2.5	3.4	2.7	3.6	2.8	3.7	2.8	4.0	2.8	4.3	2.7
	18	10.5	2.5	2.2	2.9	2.5	3.4	2.7	3.6	2.8	3.7	2.8	4.0	2.8	4.3	2.7
	20	12	2.5	2.2	2.9	2.5	3.4	2.7	3.6	2.8	3.7	2.8	4.0	2.8	4.2	2.6
	21	14	2.5	2.2	2.9	2.5	3.4	2.7	3.6	2.8	3.7	2.8	4.0	2.8	4.2	2.6
	23	15	2.5	2.2	2.9	2.5	3.4	2.7	3.6	2.8	3.7	2.8	4.0	2.8	4.2	2.6
	25	16	2.5	2.2	2.9	2.5	3.4	2.7	3.6	2.8	3.7	2.8	4.0	2.8	4.2	2.6
	27	18	2.5	2.2	2.9	2.5	3.4	2.7	3.6	2.8	3.7	2.8	4.0	2.8	4.2	2.6
	29	19	2.5	2.2	2.9	2.5	3.4	2.7	3.6	2.8	3.7	2.8	4.0	2.8	4.2	2.6
	31	22	2.5	2.2	2.9	2.5	3.4	2.7	3.6	2.8	3.7	2.8	4.0	2.8	4.2	2.6
	35	24	2.5	2.2	2.9	2.5	3.4	2.7	3.6	2.8	3.7	2.8	4.0	2.8	4.2	2.6
	37	26	2.5	2.2	2.9	2.5	3.4	2.7	3.6	2.8	3.7	2.8	3.9	2.7	4.2	2.6
	39	28	2.5	2.2	2.9	2.5	3.4	2.7	3.6	2.8	3.7	2.8	3.9	2.7	4.1	2.5
	42	29	2.5	2.2	2.9	2.5	3.4	2.7	3.5	2.7	3.6	2.6	3.7	2.6	3.9	2.4
44	30	2.5	2.2	2.9	2.5	3.2	2.6	3.4	2.6	3.5	2.5	3.5	2.5	3.6	2.3	
1000	10	4	4.9	4.3	5.8	5.0	6.7	5.2	7.1	5.4	7.4	5.6	8.0	5.7	8.5	5.4
	12	5.5	4.9	4.3	5.8	5.0	6.7	5.2	7.1	5.4	7.4	5.6	7.9	5.6	8.5	5.4
	14	7	4.9	4.3	5.8	5.0	6.7	5.2	7.1	5.4	7.4	5.6	7.9	5.6	8.5	5.4
	16	8.5	4.9	4.3	5.8	5.0	6.7	5.2	7.1	5.4	7.4	5.6	7.9	5.6	8.4	5.3
	18	10.5	4.9	4.3	5.8	5.0	6.7	5.2	7.1	5.4	7.4	5.6	7.9	5.6	8.4	5.3
	20	12	4.9	4.3	5.8	5.0	6.7	5.2	7.1	5.4	7.4	5.6	7.9	5.6	8.4	5.3
	21	14	4.9	4.3	5.8	5.0	6.7	5.2	7.1	5.4	7.4	5.6	7.9	5.6	8.4	5.3
	23	15	4.9	4.3	5.8	5.0	6.7	5.2	7.1	5.4	7.4	5.6	7.9	5.6	8.4	5.3
	25	16	4.9	4.3	5.8	5.0	6.7	5.2	7.1	5.4	7.4	5.6	7.9	5.6	8.4	5.3
	27	18	4.9	4.3	5.8	5.0	6.7	5.2	7.1	5.4	7.4	5.6	7.9	5.6	8.4	5.3
	29	19	4.9	4.3	5.8	5.0	6.7	5.2	7.1	5.4	7.4	5.6	7.9	5.6	8.4	5.3
	31	22	4.9	4.3	5.8	5.0	6.7	5.2	7.1	5.4	7.4	5.6	7.9	5.6	8.4	5.3
	35	24	4.9	4.3	5.8	5.0	6.7	5.2	7.1	5.4	7.4	5.6	7.9	5.6	8.4	5.3
	37	26	4.9	4.3	5.8	5.0	6.7	5.2	7.1	5.4	7.3	5.5	7.8	5.5	8.2	5.2
	39	28	4.9	4.3	5.8	5.0	6.7	5.2	7.1	5.4	7.3	5.5	7.7	5.4	8.1	5.1
	42	29	4.9	4.3	5.8	5.0	6.7	5.2	6.9	5.3	7.0	5.4	7.3	5.3	7.6	4.9
44	30	4.9	4.3	5.8	5.0	6.3	5.0	6.7	5.2	6.8	5.3	7.0	5.2	7.1	4.7	

Ventilation

2) Heating

TC : Total Capacity(kW)

Model	Outdoor temperature (°C)		Indoor temperature (°C, DB)				
			16.0	18.0	20.0	22.0	24.0
	DB	WB	TC kW	TC kW	TC kW	TC kW	TC kW
500	-20	-21	-	-	-	-	-
	-17	-18	-	-	-	-	-
	-15	-16	-	-	-	-	-
	-12	-13	-	-	-	-	-
	-10	-11	2.9	2.9	2.9	2.8	2.8
	-7	-8	3.1	3.1	3.0	3.0	2.9
	-5	-6	3.3	3.2	3.2	3.1	3.0
	-3	-4	3.4	3.4	3.3	3.2	3.1
	0	-1	3.6	3.6	3.5	3.4	3.2
	3	2.2	3.8	3.7	3.7	3.5	3.4
	5	4.1	3.9	3.9	3.8	3.6	3.4
	7	6	4.1	4.1	4.0	3.7	3.4
	9	7.9	4.2	4.1	4.0	3.7	3.4
	11	9.8	4.4	4.2	4.0	3.7	3.4
	13	12	4.5	4.2	4.0	3.7	3.4
	15	14	4.6	4.3	4.0	3.7	3.4
1000	-20	-21	-	-	-	-	-
	-17	-18	-	-	-	-	-
	-15	-16	-	-	-	-	-
	-12	-13	-	-	-	-	-
	-10	-11	5.9	5.8	5.7	5.6	5.6
	-7	-8	6.2	6.1	6.0	5.9	5.8
	-5	-6	6.5	6.5	6.4	6.2	6.0
	-3	-4	6.9	6.8	6.7	6.4	6.2
	0	-1	7.2	7.1	7.0	6.7	6.4
	3	2.2	7.6	7.5	7.3	7.1	6.8
	5	4.1	7.9	7.8	7.7	7.2	6.8
	7	6	8.2	8.1	8.0	7.4	6.8
	9	7.9	8.5	8.2	8.0	7.4	6.8
	11	9.8	8.7	8.4	8.0	7.4	6.8
	13	12	9.0	8.5	8.0	7.4	6.8
	15	14	9.2	8.6	8.0	7.4	6.8

1 ERV PLUS

1-3. Dimensional drawing

1) RH050/100KHEA

Unit:mm

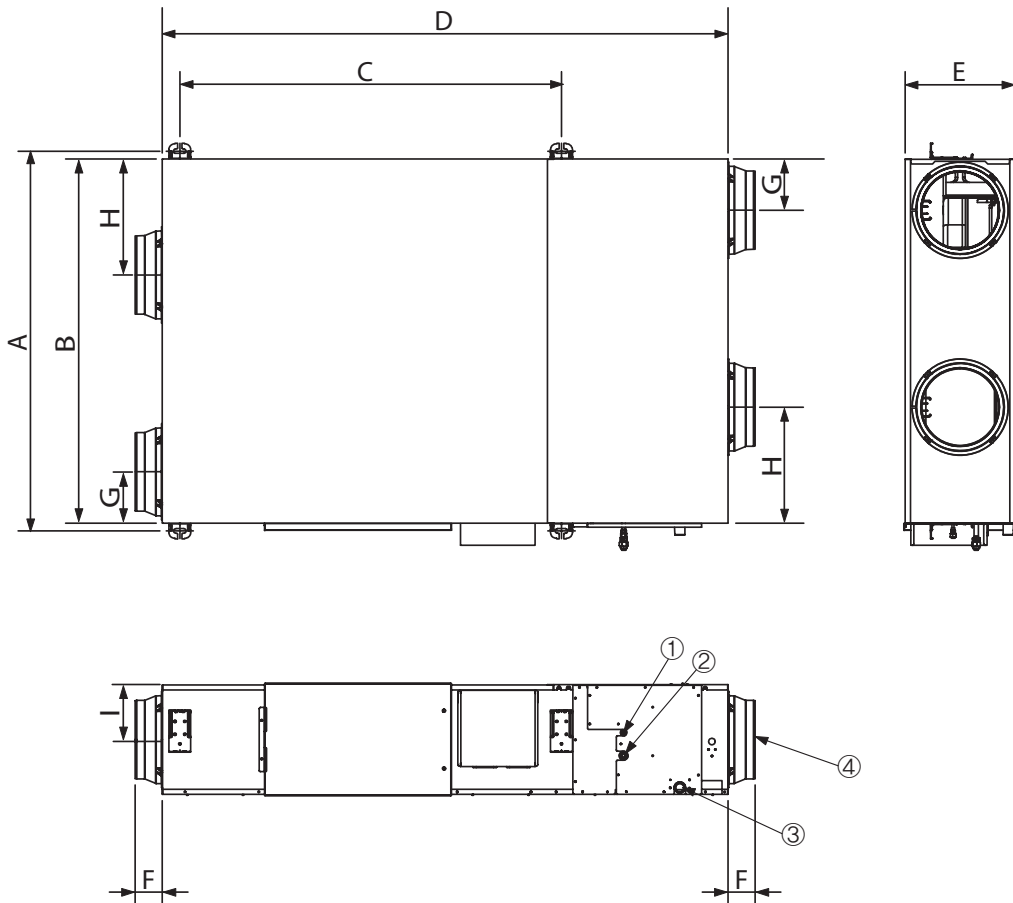

Model	A	B	C	D	E	F	G	H	I
RHF050KHEA	1036	1000	987	1553	270	99	130	253	135
RHF100KHEA	1183	1135	1189	1763	340	84	160	362	170

No.	Name	Description	
		500CMH	1000CMH
①	Liquid pipe connection	Ø6.35 (1/4")	
②	Gas pipe connection	Ø12.70 (1/2")	
③	Drain pipe connection	VP25 (OD Ø32, ID Ø25)	
④	Nominal diameter for duct	RHF050KHEA	Ø200
		RHF100KHEA	Ø250

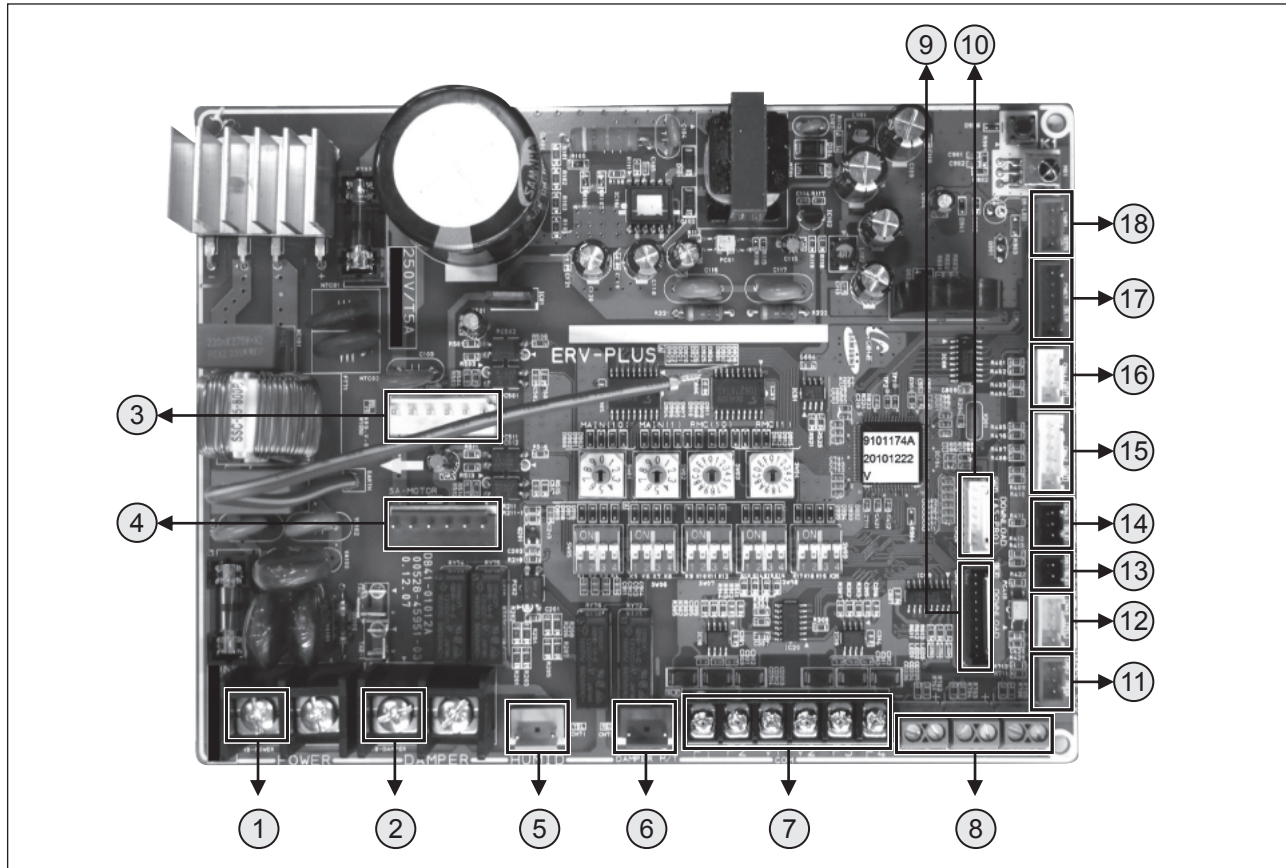

1-4. PCB connector lay-out

1) RH050/100KHEA



Ventilation

No.	CN #	COLOR	FUNCTION
①	-	-	Power Input(AC POWER)
②	-	-	Outside Damper
③	CN73	White	EA FAN MOTOR
④	CN74	Blue	SA FAN MOTOR
⑤	CN71	Yellow	Humidifying Sol Valve
⑥	CN72	Red	Internal Damper
⑦	-	-	Communication Terminal
⑧	-	-	External Point of Contact Control
⑨	CN10	Black	Download Part
⑩	CN20	White	Download Part
⑪	CN52	Red	Damper Switch
⑫	CN54	Yellow	SPi
⑬	CN51	Black	Float switch
⑭	CN43	Black	CO ₂ Sensor
⑮	CN42	White	EAVOA temp. sensor
⑯	CN41	White	Room temp. EVA in/out temp.
⑰	CN62	Blue	EEV
⑱	CN81	Red	External Monitor Output

No.	S/W	FUNCTION	
A		Main Address Setting (00~63)	
		SW03	SW04
B		Address of Interface Module Channel 0~2	Group Address (RMC) for Centralized Control 0~F

No.	S/W	FUNCTION	ON	OFF
C	K1	Remote sensor	No use	Use
	K2	Central control	No use	Use
	K3	-	-	-
	K4	Humidifier	No use	Use
	K5	Heating temperature compensation	2°C	5°C
	K6	Filter time	1000 hours	2000 hours
	K7, K8	-	-	-
	K9	EEV stop step in heating	Low	High
	K10	Priority of display on wired R/C	160	35/160
	K11	External control	No use	Use
	K12	State output	Output during operation	Output during thermo-on
	K13, K14	-	-	-
	K15	External damper	No use	Use
	K16	S-Plasma ion kit	No use	Use
	K17	CO ₂ sensor	No use	Use
	K18	Special EEV control skip in heating	No use	Use
	K19	Clean-up	Exhaustion air RPM fixed to RPM in Quiet mode	Supply air RPM fixed to RPM in Quiet mode
	K20	-	-	-

1 ERV PLUS

1-5. Electrical wiring diagram

1) RH050/100KHEA

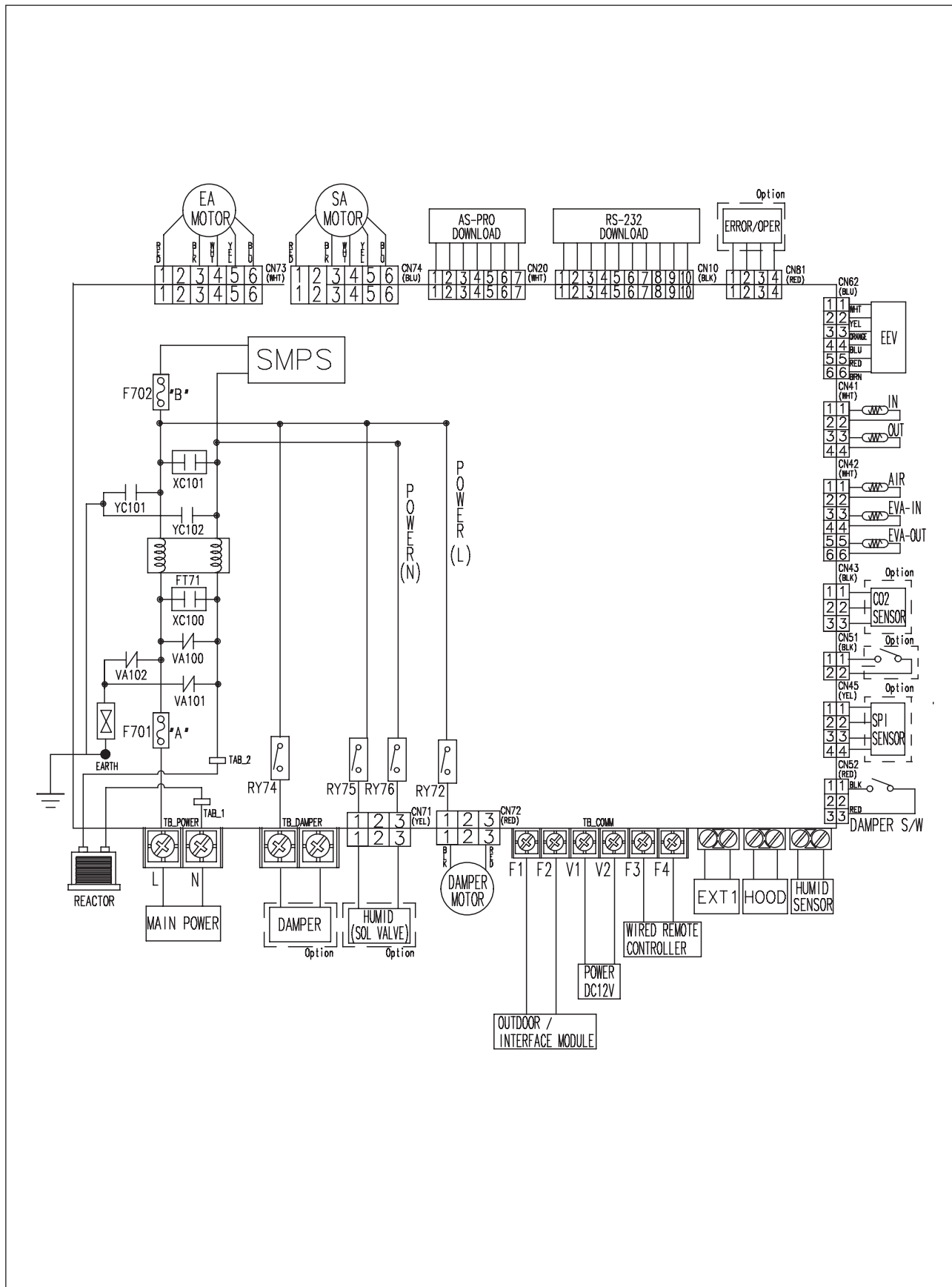

1-6. Sound pressure level

1) Operation sound level

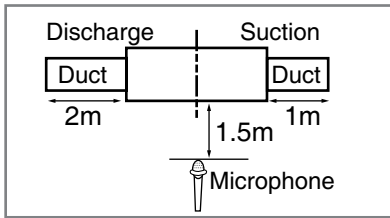

Unit : dB(A)

Model	Turbo	High	Low
RHF050KHEA	38.5	36.0	32.0
RHF100KHEA	40.5	38.0	35.0

2) NC curves

(1) RHF050KHEA

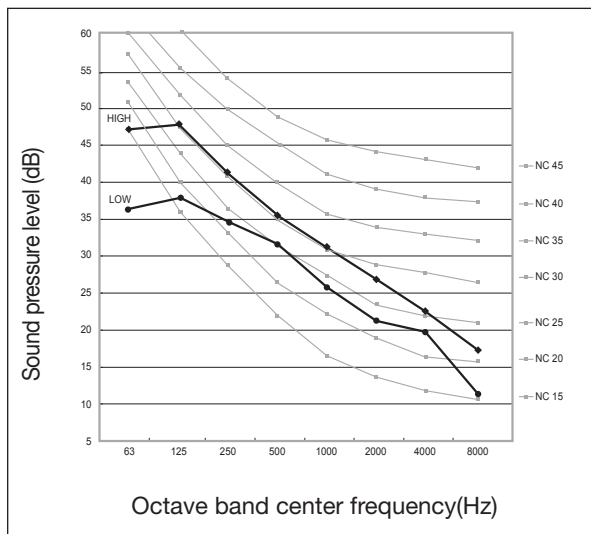

(2) RHF100KHEA

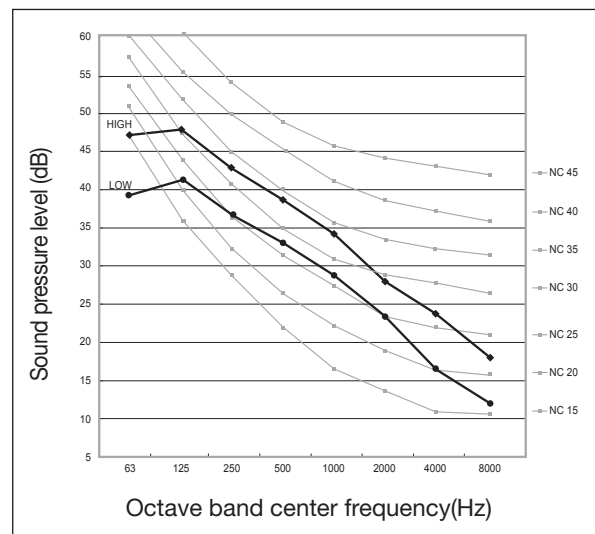

Ventilation

1-7. Recommended operation range

(1) RH050KHEA

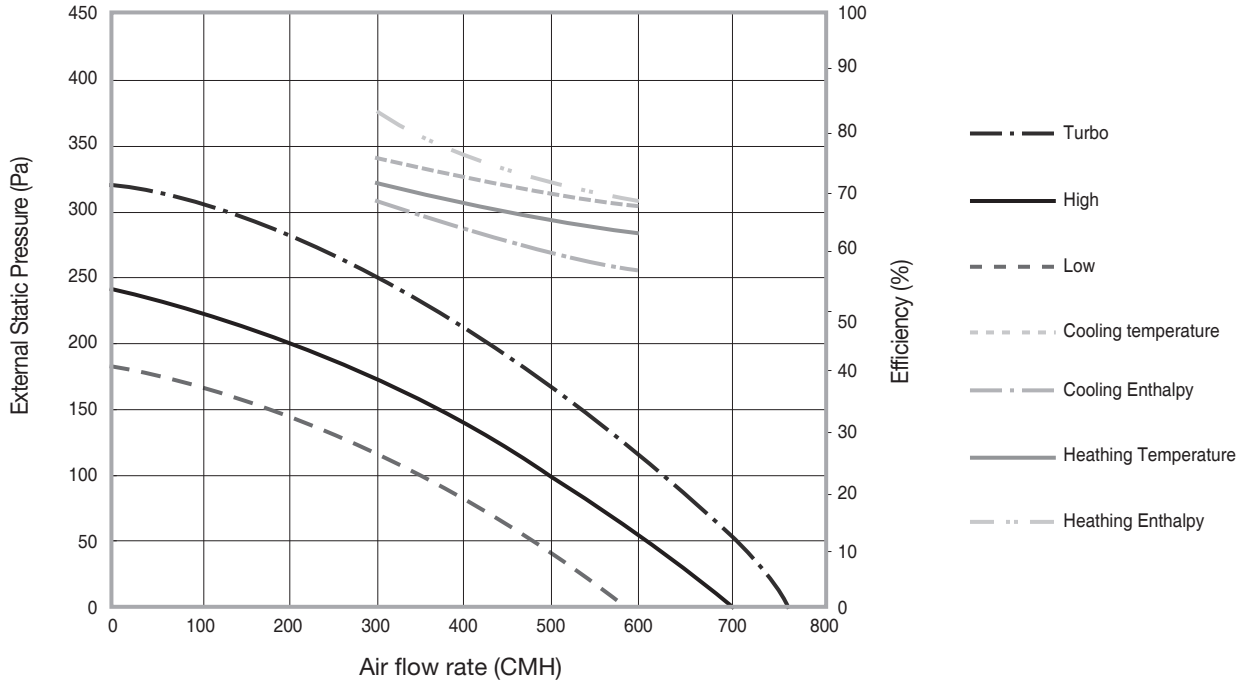

(2) RH100KHEA

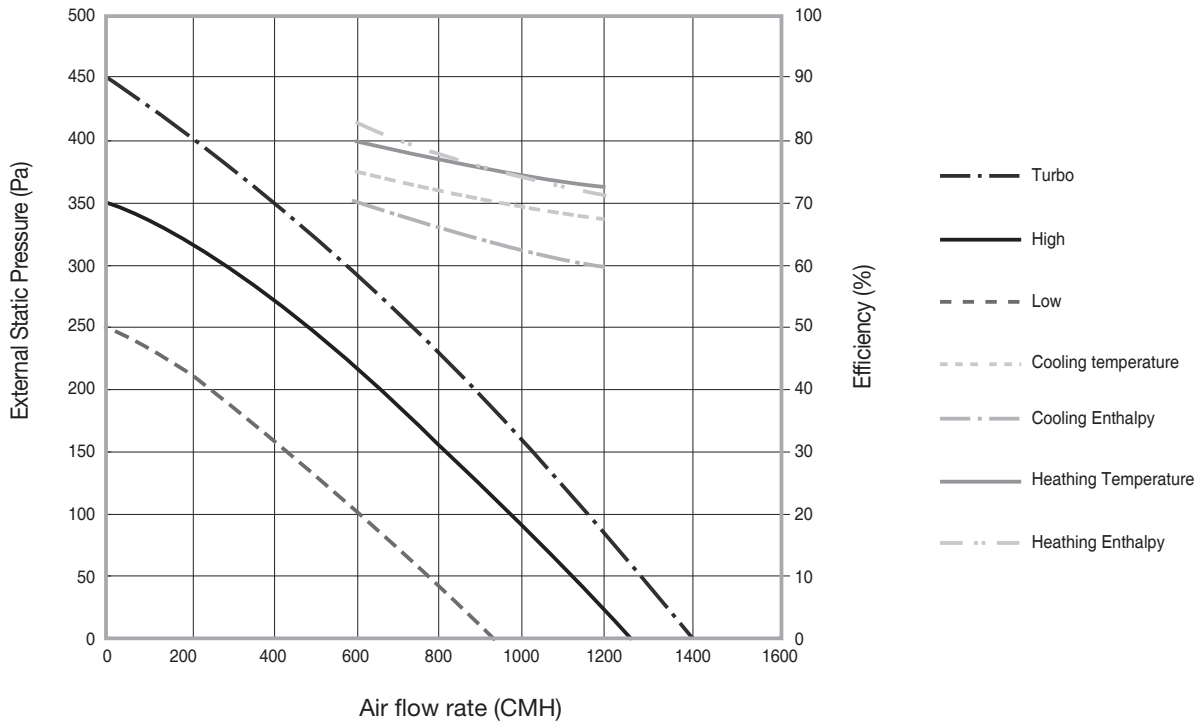

IV. Setting

- 1 Setting an indoor unit address and installation option(4 way cassette S) 166

1 Setting an indoor unit address and installation option(4 way cassette S)

Set the indoor unit address and installation option with remote controller option.

Set the each option separately since you cannot set the ADDRESS setting and indoor unit installation setting option at the same time. You need to set twice when setting indoor unit address and installation option.

1-1. The procedure of option setting

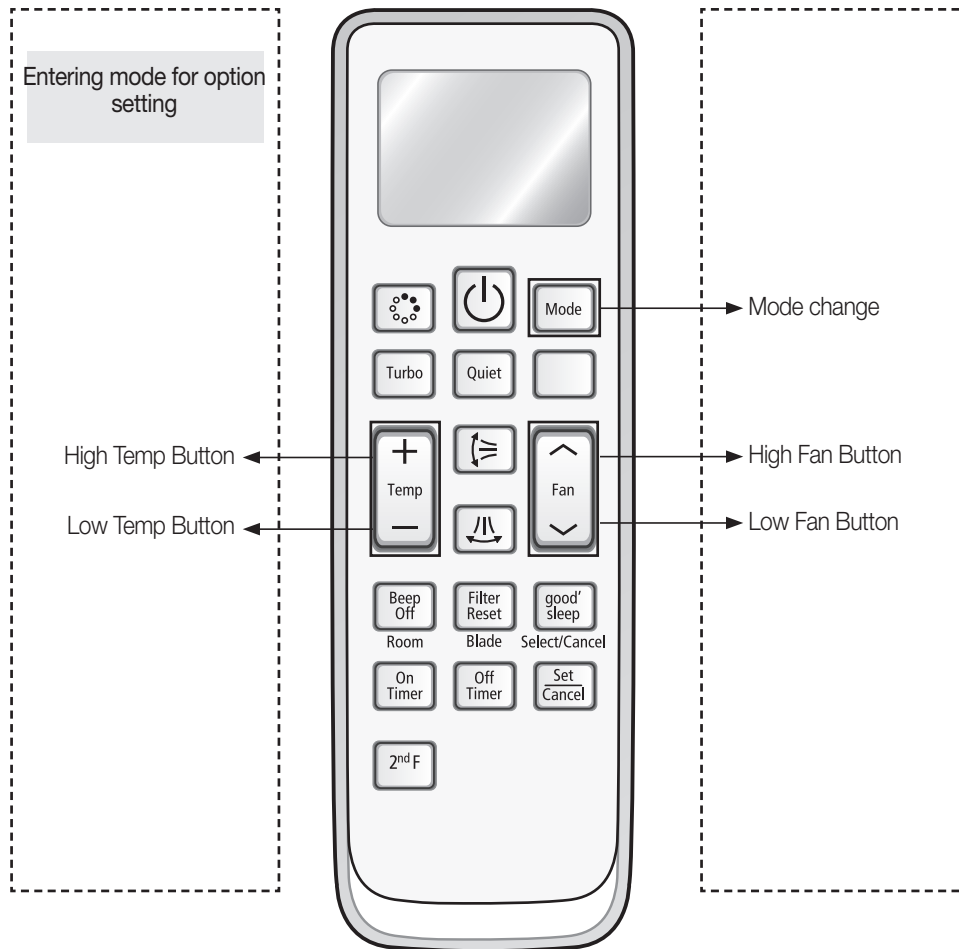

Step 1. Entering mode to set option

- ① Remove batteries from the remote controller.
- ② Insert batteries and enter the option setting mode while pressing High Temp button and Low Temp button.



- ③ Check if you have entered the option setting status.

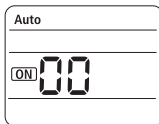

Step 2. The procedure of option setting

After entering the option setting status, select the option as listed below.















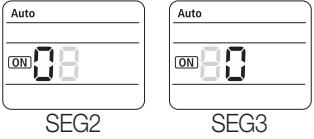

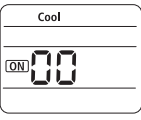



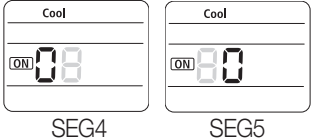

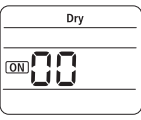



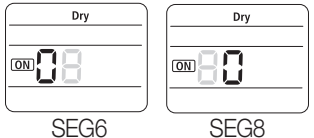

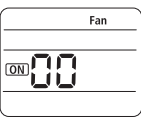



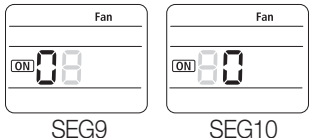

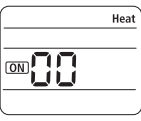

Option setting is available from SEG1 to SEG 24

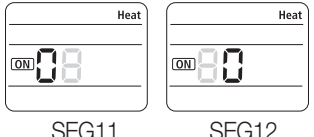
- SEG1, SEG7, SEG13, SEG19 are not set as page option.
- Set the SEG2~SEG6, SEG8~SEG12 as ON status and SEG14~18, SEG20~24 as OFF status.

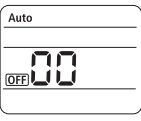



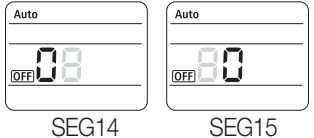

SEG1	SEG2	SEG3	SEG4	SEG5	SEG6	SEG7	SEG8	SEG9	SEG10	SEG11	SEG12
0	X	X	X	X	X	1	X	X	X	X	X
SEG13	SEG14	SEG15	SEG16	SEG17	SEG18	SEG19	SEG20	SEG21	SEG22	SEG23	SEG24
2	X	X	X	X	X	3	X	X	X	X	X

On(SEG1~12)	Off(SEG13~24)

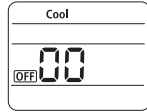
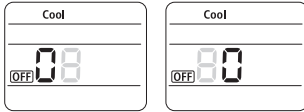
Option setting	Status
<p>1. Setting SEG2, SEG3 option Press Low Fan button(V) to enter SEG2 value. Press High Fan button(Λ) to enter SEG3 value. Each time you press the button,  →  → ...  →  will be selected in rotation.</p>	 <p>SEG2 SEG3</p>
<p>2. Setting Cool mode  Press Mode button to be changed to Cool mode in the ON status.</p>	
<p>3. Setting SEG4, SEG5 option Press Low Fan button(V) to enter SEG4 value. Press High Fan button(Λ) to enter SEG5 value. Each time you press the button,  →  → ...  →  will be selected in rotation.</p>	 <p>SEG4 SEG5</p>
<p>4. Setting Dry mode  Press Mode button to be changed to DRY mode in the ON status.</p>	
<p>5. Setting SEG6, SEG8 option Press Low Fan button(V) to enter SEG6 value. Press High Fan button(Λ) to enter SEG8 value. Each time you press the button,  →  → ...  →  will be selected in rotation.</p>	 <p>SEG6 SEG8</p>
<p>6. Setting Fan mode  Press Mode button to be changed to FAN mode in the ON status.</p>	
<p>7. Setting SEG9, SEG10 option Press Low Fan button(V) to enter SEG9 value. Press High Fan button(Λ) to enter SEG10 value. Each time you press the button,  →  → ...  →  will be selected in rotation.</p>	 <p>SEG9 SEG10</p>
<p>8. Setting Heat mode  Press Mode button to be changed to HEAT mode in the ON status.</p>	
<p>9. Setting SEG11, SEG12 option Press Low Fan button(V) to enter SEG11 value. Press High Fan button(Λ) to enter SEG12 value. Each time you press the button,  →  → ...  →  will be selected in rotation.</p>	 <p>SEG11 SEG12</p>
<p>10. Setting Auto mode  Press Mode button to be changed to AUTO mode in the OFF status.</p>	
<p>11. Setting SEG14, SEG15 option Press Low Fan button(V) to enter SEG14 value. Press High Fan button(Λ) to enter SEG15 value. Each time you press the button,  →  → ...  →  will be selected in rotation.</p>	 <p>SEG14 SEG15</p>

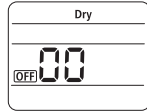
Setting an indoor unit address and installation option(4 way cassette S)

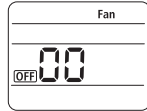
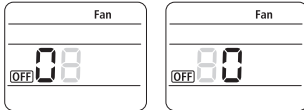
1-1. The procedure of option setting

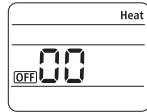
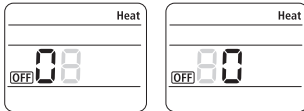
Option setting	Status
12. Setting Cool mode  Press Mode button to be change to Cool mode in the OFF status.	
13. Setting SEG16, SEG17 option Press Low Fan button(V) to enter SEG16 value. Press High Fan button(^) to enter SEG17 value. Each time you press the button, 0 → 1 → ... 9 → 0 will be selected in rotation.	
14. Setting Dry mode  Press Mode button to be change to Dry mode in the OFF status.	
15. Setting SEG18, SEG20 option Press Low Fan button(V) to enter SEG18 value. Press High Fan button(^) to enter SEG20 value. Each time you press the button, 0 → 1 → ... 9 → 0 will be selected in rotation.	
16. Setting Fan mode  Press Mode button to be change to Fan mode in the OFF status.	
17. Setting SEG21, SEG22 option Press Low Fan button(V) to enter SEG21 value. Press High Fan button(^) to enter SEG22 value. Each time you press the button, 0 → 1 → ... 9 → 0 will be selected in rotation.	
18. Setting Heat mode  Press Mode button to be change to HEAT mode in the OFF status.	
19. Setting SEG23, SEG24 mode Press Low Fan button(V) to enter SEG23 value. Press High Fan button(^) to enter SEG24 value. Each time you press the button, 0 → 1 → ... 9 → 0 will be selected in rotation.	

Step 3. Check the option you have set

After setting option, press  button to check whether the option code you input is correct or not.

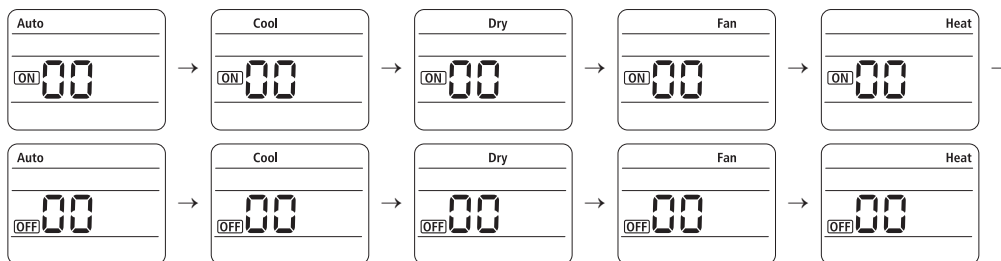

Step 4. Input option

Press operation button  with the direction of remote control for set.
For the correct option setting, you must input the option twice.

Step 5. Check operation

- ①. Reset the indoor unit by pressing the RESET button of indoor unit or outdoor unit.
- ②. Take the batteries out of the remote controller and insert them again and then press the operation button.

1-2. Setting an indoor unit address (MAIN/RMC)

- 1) Check whether power is supplied or not.
 - When the indoor unit is not plugged in, there should be additional power supply in the indoor unit.
- 2) The panel(display) should be connected to an indoor unit to receive option.
- 3) Before installing the indoor unit, assign an address to the indoor unit according to the air conditioning system plan.
- 4) Assign an indoor unit address by wireless remote controller.
 - The initial setting status of indoor unit ADDRESS(MAIN/RMC) is "0A0000-100000-200000-300000".

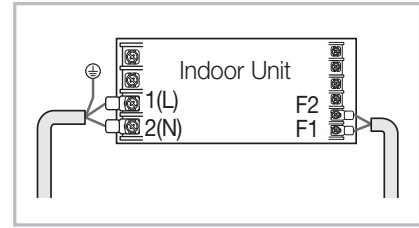

Option No. : 0AXXXX-1XXXXX-2XXXXX-3XXXXX

Option	SEG1		SEG2		SEG3		SEG4		SEG5		SEG6	
Explanation	PAGE		MODE		Setting Main address		100-digit of indoor unit address		10-digit of indoor unit		The unit digit of an indoor unit	
Remote Controller Display												
Indication and Details	Indication	Details	Indication	Details	Indication	Details	Indication	Details	Indication	Details	Indication	Details
	0		A		0	No Main address	0~9	100-digit	0~9	10-digit	0~9	A unit digit
Option	SEG7		SEG8		SEG9		SEG10		SEG11		SEG12	
Explanation	PAGE				Setting RMC address				Group channel(*16)		Group address	
Remote Controller Display												
Indication and Details	Indication	Details	Indication	Details	Indication	Details	Indication	Details	Indication	Details	Indication	Details
	1				0	No RMC address			RMC1	0~2	RMC2	0~F



- When "A"~"F" is entered to SEG5~6, the indoor unit MAIN ADDRESS is not changed.
- If you set the SEG 3 as 0, the indoor unit will maintain the previous MAIN ADDRESS even if you input the option value of SEG5~6.
- If you set the SEG 9 as 0, the indoor unit will maintain previous RMC ADDRESS even if you input the option value of SEG11~12.

1-3. Setting an indoor unit installation option (suitable for the condition of each installation location)

- 1) Check whether power is supplied or not.
- When the indoor unit is not plugged in, there should be additional power supply in the indoor unit.
- 2) The panel(display) should be connected to an indoor unit to receive option.
- 3) Set the installation option according to the installation condition of an air conditioner.

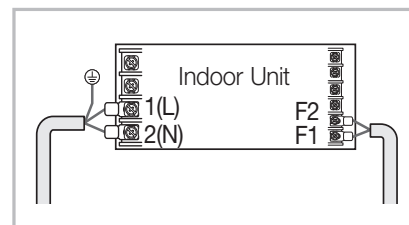

- The default setting of an indoor unit installation option is "02000-100000-200000-300000".
 - Individual control of a remote controller(SEG20) is the function that controls an indoor unit individually when there is more than one indoor unit.
- 4) Set the indoor unit option by wireless remote controller.

SEG1	SEG2	SEG3	SEG4	SEG5	SEG6
0	2	RESERVED	Exterior temperature sensor	Central control	FAN RPM compensation
SEG7	SEG8	SEG9	SEG10	SEG11	SEG12
1	Drain pump	Hot water heater	Electronic heater	Opening the electronic expansion valve	Master / Slave
SEG13	SEG14	SEG15	SEG16	SEG17	SEG18
2	External control	External control output	S-Plasma ion	Buzzer	Number of hours using filter
SEG19	SEG20	SEG21	SEG22	SEG23	SEG24
3	Individual control of a remote controller	Heating setting compensation	EEV opening of an indoor unit stopped during oil return or Defrost operation.	-	-

- ▶ 1WAY/2WAY/4WAY MODEL : Drain pump(SEG8) will be set to 'USE + 3minute delay' even if the drain pump is set to 0.
- ▶ 1 WAY/2WAY/4WAY,DUCT MODEL : Number of hours using filter(SEG18) will be set to '1000hour' even if the SEG18 is set to except for 2 or 6.
- ▶ If you input a number other than 0~4 of the individual control of the indoor unit(SEG20), the indoor is set as "indoor 1".

Option No. : 02XXXX-1XXXX-2XXXX-3XXXX

Option	SEG1		SEG2		SEG3		SEG4		SEG5		SEG6											
Explanation	PAGE		MODE		RESERVED		Use of external temperature sensor		Use of central control		FAN RPM compensation											
Remote Controller Display																						
Indication and Details	Indication	Details	0	2	Indication	Details	0	Disuse	0	Disuse	0	Disuse										
											1	RPM compensation										
											2	High ceiling KIT										
Option	SEG7		SEG8		SEG9		SEG10		SEG11		SEG12											
Explanation	PAGE		Use of drain pump		Use of hot water heater		Use of electronic heater		Opening the electronic expansion valve of an indoor unit when heating operation stops.		Master / Slave											
Remote Controller Display																						
Indication and Details	Indication	Details	1	Use + 3minute delay	Indication	Details	0	Disuse	0	Disuse	0	slave										
											1	Use										
											2	Use + 3minute delay										
Indication and Details	Indication	Details	0	Disuse	Indication	Details	0	Disuse	0	0	0	1000 Hour										
													1	ON/OFF Control	1	Operation on	1	Use	1	Mixed operation control1/ Disuse of buzzer	6	2000 Hour
													2	OFF Control					2	Mixed operation control2/ Use buzzer		
3	Mixed operation control2/ Disuse of buzzer																					
Option	SEG13		SEG14		SEG15		SEG16		SEG17		SEG18											
Explanation	PAGE		Use of external control		Setting the output of external control		S-Plasma ion		Buzzer control		Number of hours using filter											
Remote Controller Display																						
Indication and Details	Indication	Details	0 or 1	channel 1	Indication	Details	0	Disuse	0	150 step	Indication	Details										
													2	channel 2	1	0 step	Indication	Details				
													3	channel 3								
4	channel 4																					
Option	SEG19		SEG20		SEG21		SEG22		SEG23		SEG24											
Explanation	PAGE		Individual control of a remote controller		Heating setting compensation		EEV opening of an indoor unit stopped during oil return or defrost operation.		RESERVED		RESERVED											
Remote Controller Display																						
Indication and Details	Indication	Details	3	channel 1	Indication	Details	0	Disuse	0	150 step	Indication	Details										
													2	channel 2	1	0 step	Indication	Details				
													3	channel 3								
													4	channel 4								

Setting an indoor unit address and installation option(4 way cassette S)

1-4. Changing a particular option

You can change each digit of set option.

Option	SEG1		SEG2		SEG3		SEG4		SEG5		SEG6	
Explanation	PAGE		MODE		The option mode you want to change		The tens' digit of an option SEG you will change		The unit digit of an option SEG you will change		The changed value	
Remote Controller Display												
Indication and Details	Indication	Details	Indication	Details	Indication	Details	Indication	Details	Indication	Details	Indication	Details
	0		D		Option mode	0~F	Tens' digit of SEG	0~9	Unit digit of SEG	0~9	The changed value	0~F

Note

- ◆ When changing a digit of an indoor unit address setting option, set the SEG3 as 'A'.
- ◆ When changing a digit of indoor unit installation option, set the SEG3 as '2'.

Ex) When setting the 'buzzer control' into disuse status.

Option	SEG1	SEG2	SEG3	SEG4	SEG5	SEG6
Explanation	PAGE	MODE	The option mode you want to change	The tens' digit of an option SEG you will change	The unit digit of an option SEG you will change	The changed value
Indication	0	D	2	1	7	1

DVM Technical Data Book

DVMM

SAMSUNG

2011. 09
DB98-11043Z(2)

SAMSUNG

Samsung Electronics Co., LTD.
Digital Air Solution Marketing Group/SE

Head Office (Suwon Korea) 416, Maetan-3Dong, Yeongtong-Gu, Suwon City, Gyeonggi-Do, Korea 443-742
TEL : 82-31-200-0788 Website : www.dvmsystem.com Email: Airconditioner@samsung.com